



DATA SHEET

GLL170-P332

GLL170
Fiber-optic sensors

SICK

Sensor Intelligence

FIBER-OPTIC SENSORS

GLL170-P332

ORDERING INFORMATION

Type	part no.
GLL170-P332	6063334

Further device versions and accessories at www.sick.com/GLL170



Illustration may differ



DETAILED TECHNICAL DATA

FEATURES

Device type	Fiber-optic amplifier	
Device type detail	Stand-alone	
Functional principle detail	Depending on the optical fiber cable used	
Sensing range max.	Depending on the optical fiber cable used	
Emitted beam	Light source	LED ¹⁾
	Type of light	Visible red light
Key LED figures	Normative reference	EN 62471:2008-09 IEC 62471:2006, modified
	LED risk group marking	Free group
	Wave length	632 nm
	Average service life	100,000 h at T _a = +25 °C
Adjustment	Potentiometer	For setting the sensing range/for setting the switching mode/for adjusting the switch-off delay
	Display	
	LED green	Operating indicator Static on: power on Dimmed in the range +/- 10 % of the switching threshold
	LED yellow	Status of digital output Permanently on: Switching output active Permanently off: Digital output not active

¹⁾ Average service life: 100,000 h at T_a = +25 °C.

SAFETY-RELATED PARAMETERS

MTTF _D	760 years
DC _{avg}	0 %
T _M (mission time)	20 years

ELECTRONICS

Supply voltage U _B	10 V DC ... 30 V DC ¹⁾																						
Ripple	≤ 10 % ²⁾																						
Current consumption	≤ 30 mA ³⁾																						
Protection class	III																						
Digital output	<table border="0"> <tr> <td>Number</td> <td>1</td> </tr> <tr> <td>Type</td> <td>PNP ⁴⁾</td> </tr> <tr> <td>Switching mode</td> <td>Light/dark switching</td> </tr> <tr> <td>Signal voltage PNP HIGH/LOW</td> <td>Approx. U_B-1.5 V / 0 V</td> </tr> <tr> <td>Signal voltage NPN HIGH/LOW</td> <td>Approx. U_B / < 1.5 V</td> </tr> <tr> <td>Output current I_{max.}</td> <td>≤ 100 mA</td> </tr> <tr> <td>Circuit protection outputs</td> <td>Reverse polarity protected Overcurrent protected Short-circuit protected</td> </tr> <tr> <td>Response time</td> <td>≤ 250 μs</td> </tr> <tr> <td>Switching frequency</td> <td>2 kHz</td> </tr> <tr> <td>Time functions</td> <td>Without time delay, off delay</td> </tr> <tr> <td>Delay time</td> <td>Selectable via rotary switch, 0 ms ... 40 ms</td> </tr> </table>	Number	1	Type	PNP ⁴⁾	Switching mode	Light/dark switching	Signal voltage PNP HIGH/LOW	Approx. U _B -1.5 V / 0 V	Signal voltage NPN HIGH/LOW	Approx. U _B / < 1.5 V	Output current I _{max.}	≤ 100 mA	Circuit protection outputs	Reverse polarity protected Overcurrent protected Short-circuit protected	Response time	≤ 250 μs	Switching frequency	2 kHz	Time functions	Without time delay, off delay	Delay time	Selectable via rotary switch, 0 ms ... 40 ms
Number	1																						
Type	PNP ⁴⁾																						
Switching mode	Light/dark switching																						
Signal voltage PNP HIGH/LOW	Approx. U _B -1.5 V / 0 V																						
Signal voltage NPN HIGH/LOW	Approx. U _B / < 1.5 V																						
Output current I _{max.}	≤ 100 mA																						
Circuit protection outputs	Reverse polarity protected Overcurrent protected Short-circuit protected																						
Response time	≤ 250 μs																						
Switching frequency	2 kHz																						
Time functions	Without time delay, off delay																						
Delay time	Selectable via rotary switch, 0 ms ... 40 ms																						
Pin/Wire assignment	<table border="0"> <tr> <td>Function of pin 4/black (BK)</td> <td>Digital output, received light → Output Q1 HIGH</td> </tr> <tr> <td>Function of pin 4/black (BK) – detail</td> <td>The pin 4 function of the sensor can be configured</td> </tr> </table>	Function of pin 4/black (BK)	Digital output, received light → Output Q1 HIGH	Function of pin 4/black (BK) – detail	The pin 4 function of the sensor can be configured																		
Function of pin 4/black (BK)	Digital output, received light → Output Q1 HIGH																						
Function of pin 4/black (BK) – detail	The pin 4 function of the sensor can be configured																						

¹⁾ Limit values.

²⁾ May not fall below or exceed U_B tolerances.

³⁾ Without load.

⁴⁾ Selectable via rotary switch.

MECHANICS

Housing	Rectangular								
Dimensions (W x H x D)	10 mm x 31.7 mm x 72.5 mm								
Connection	Cable, 3-wire								
Connection detail	<table border="0"> <tr> <td>Deep-freeze property</td> <td>Do not bend below 0 °C</td> </tr> <tr> <td>Conductor size</td> <td>0.2 mm²</td> </tr> <tr> <td>Cable diameter</td> <td>Ø 3.8 mm</td> </tr> <tr> <td>Length of cable (L)</td> <td>2 m</td> </tr> </table>	Deep-freeze property	Do not bend below 0 °C	Conductor size	0.2 mm ²	Cable diameter	Ø 3.8 mm	Length of cable (L)	2 m
Deep-freeze property	Do not bend below 0 °C								
Conductor size	0.2 mm ²								
Cable diameter	Ø 3.8 mm								
Length of cable (L)	2 m								
Material	<table border="0"> <tr> <td>Housing</td> <td>Plastic, PC/POM</td> </tr> <tr> <td>Cable</td> <td>Plastic, PVC</td> </tr> </table>	Housing	Plastic, PC/POM	Cable	Plastic, PVC				
Housing	Plastic, PC/POM								
Cable	Plastic, PVC								
Weight	63 g								
Maximum tightening torque of the fixing screws	0.5 Nm								

AMBIENT DATA

Enclosure rating	IP66 (EN 60529)
Ambient operating temperature	-25 °C ... +55 °C
Ambient temperature, storage	-40 °C ... +70 °C

FIBER-OPTIC SENSORS - GLL170-P332

Typ. Ambient light immunity	Artificial light: ≤ 5,000 lx Sunlight: ≤ 60,000 lx
Shock resistance	50 g, 11 ms (3 positive and 3 negative shocks along X, Y, Z axes, 18 total shocks (EN60068-2-27))
Vibration resistance	10 Hz ... 55 Hz (Amplitude 1 mm, 3 x 30 min (EN60068-2-6))
Air humidity	35 % ... 95 %, relative humidity (no condensation)
Electromagnetic compatibility (EMC)	EN 60947-5-2
UL File No.	NRKH2.E300503 & NRKH8.E300503
RoHS certificate	✓

SMART TASK

Timer function	Deactivated Switch-on delay Off delay Impulse (one shot)
----------------	---

CERTIFICATES

EU declaration of conformity	✓
UK declaration of conformity	✓
ACMA declaration of conformity	✓
Moroccan declaration of conformity	✓
China RoHS	✓
China Compulsory Product Certification (CCC) exempt	✓
cRUus certificate	✓

ADJUSTMENTS GLL170

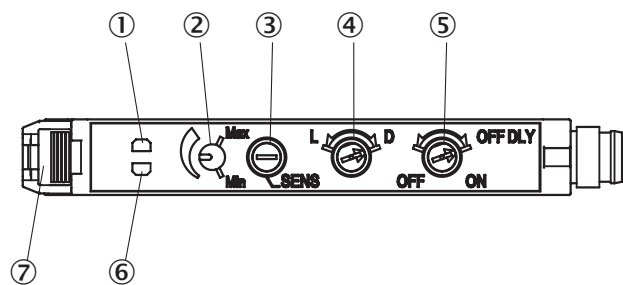

- ① LED indicator orange, lights up when switching output is active
- ② Sensitivity scale 230°
- ③ Sensitivity control: potentiometer, 8 turns
- ④ Selector switch: "L.ON" (light switching) / "D.ON" (dark switching)
- ⑤ OFF delay selector switch: "ON" (on) / "OFF" (off), 40 ms fixed
- ⑥ LED signal strength indicator green, lights up, when light received < 0.9 or > 1.1 (switching threshold = 1)
- ⑦ Locking the fiber-optic cables

CONNECTION DIAGRAM CD-043

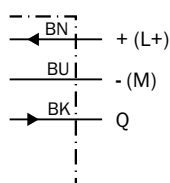

DIMENSIONAL DRAWING

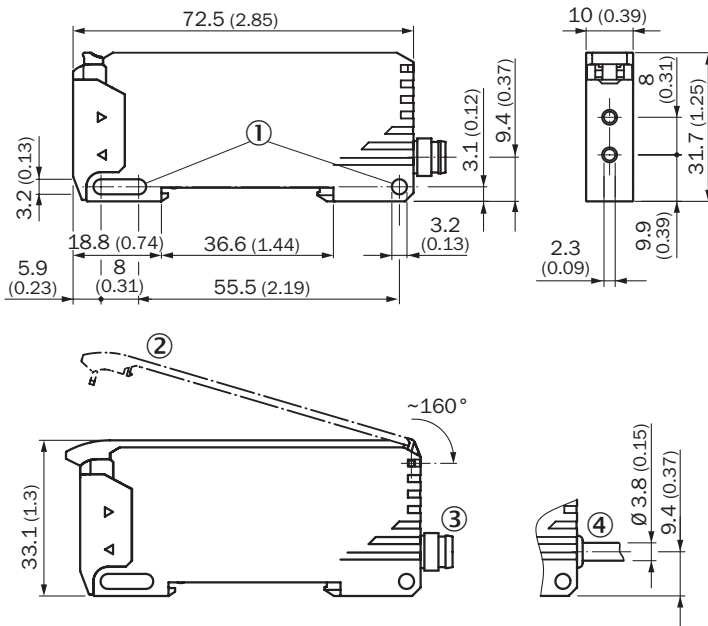

Dimensions in mm (inch)

- ① Mounting holes
- ② protective hood (optional), opens approx. 160°
- ③ Connector M8
- ④ cable

Further information as well as suitable accessories, example applications and downloads such as CAD dimensional models, operating instructions and software can be found at www.sick.com/6063334



SICK AG
WALDKIRCH
GERMANY
SICK.COM

SICK AT A GLANCE

SICK is a leading global technology company for intelligent sensors and integrated solutions in industrial automation. Our technologies set benchmarks, making your industrial processes more efficient, safer and more sustainable – both in logistics and manufacturing operations.

SICK combines sensor intelligence with industry expertise and certified consulting services. We provide the ideal foundation for scalable as well as tailor-made automation solutions and create added value along the entire value chain. Our close partnerships with our customers are more than just a promise: Together, we optimize productivity, improve quality, protect health and safety, and help build a sustainable future. All with empathy and trust.

Since 1946, we have been developing innovative technologies with passion and a pioneering spirit. With a global network in around 40 countries, SICK has a global presence and is always close by. The company's headquarters are located in Waldkirch near Freiburg, Germany. Our customers benefit from our understanding of both local and global requirements, which enables us to deliver tailor-made solutions

SICK
Sensor Intelligence