



LMS511-22100S08 Heavy Duty

LMS5xx

2D LIDAR SENSORS

SICK
Sensor Intelligence.



Ordering information

Type	part no.
LMS511-22100S08 Heavy Duty	1107125

Other models and accessories → www.sick.com/LMS5xx



Detailed technical data

Features

Application	Outdoor, Indoor
Variant	Heavy-Duty
Resolution power	High Resolution
Light source	Infrared (905 nm, ± 10 nm)
Laser class	1 (EN/IEC 60825-1:2014, EN 60825-1:2014+A11:2021)
Aperture angle	
	Horizontal 190°
Scanning frequency	25 Hz 35 Hz 50 Hz 75 Hz 100 Hz
Angular resolution	
	Horizontal 0.042°, interlaced 0.083°, interlaced 0.1667° 0.25° 0.333° 0.5° 0.667° 1°
Scan field flatness	Scan field flatness combined: ± 0.72° Typical conical error: 1 sigma value - 0.11° ± 0.1° Typical tilt: 1 sigma value + 0.15° ± 0.08°
Heating	Self-heating with additional integrated heating
Working range	0.2 m ... 80 m
Scanning range	
	At 10% remission factor 26 m

Measurement accuracy	± 12 mm
Spot size	Divergence: 4.7 mrad At the viewing window: 13.5 mm In 26 m: 136 mm In 40 m: 202 mm
Amount of evaluated echoes	5

Mechanics/electronics

Connection type	4 x M12 round connector (stainless steel)
Supply voltage	24 V DC, ± 20 %
Power consumption	22 W, + 55 W heating (typical)
Housing material	AlSi12
Housing color	Gray (RAL 7032)
Window material	Polycarbonate, scratch-resistant coating
Enclosure rating	IP65 (EN 60529, Section 14.2.7) IP67 (EN 60529, Section 14.2.7)
Protection class	III (IEC 61140:2016-11)
Weight	3.7 kg
Dimensions (L x W x H)	160 mm x 155 mm x 185 mm
MTBF	> 100 years
MTTFd	> 100 years

Safety-related parameters

MTTF_D	> 100 years
-------------------------	-------------

Performance

Response time	≥ 10 ms
Detectable object shape	Almost any
Systematic error	± 25 mm (1 m ... 10 m) ± 35 mm (10 m ... 20 m) ¹⁾
Statistical error	7 mm (1 m ... 10 m) 9 mm (10 m ... 20 m) ¹⁾
Integrated application	Field evaluation Output of measurement data
Number of field sets	10 fields
Simultaneous evaluation cases	10
Filter	Echo filter Fog filter Particle filter Average filter Glare filter

¹⁾ Typical value; actual value depends on environmental conditions.

Interfaces

Ethernet		✓, TCP/IP, UDP/IP
	Function	Host and AUX, NTP
	Data transmission rate	10/100 MBit/s
Serial		✓, RS-232, RS-422
	Function	Host and AUX

	Data transmission rate	9.6 kBaud ... 500 kBaud
CAN		✓
	Function	Extension of outputs
	Data transmission rate	20 kBit/s, 500 kBit/s, 1 MBit/s, Synchronization
USB		✓
	Remark	Mini-USB
	Function	Service interface
Digital inputs/outputs		
	Inputs	4 (Digital, encoder (HTL), synchronization)
	Outputs	6 (digital)
Optical indicators		
		5 LEDs (Additional 7-segment display)
Parameter storage		
		Integrated into system plug with cloning parameter memory

Ambient data

Remission factor		2 % ... > 1,000 % (reflectors)
Electromagnetic compatibility (EMC)		
	Emitted radiation	Industrial environment (IEC 61000-6-3:2020 / EN IEC 61000-6-3:2007+A1:2011)
	Electromagnetic immunity	Industrial environment (IEC 61000-6-2:2016 / EN IEC 61000-6-2:2019)
Vibration resistance		
	Sine test	10 Hz ... 150 Hz, Amplitude 0.35 mm to 5 g, 20 cycles ¹⁾
Shock resistance		
		15 g, 11 ms, 6 single shocks/axis ²⁾ 10 g, 16 ms, 1,000 continuous shocks/axis ²⁾
Impact resistance		
		IK05, IK06, IK07 (DIN EN 50102:09-1997)
Ambient operating temperature		
		-40 °C ... +60 °C
Storage temperature		
		-40 °C ... +70 °C
Ambient light immunity		
		70,000 lx

¹⁾ IEC 60068-2-6:2007-12.

²⁾ IEC 60068-2-27:2008-02.

General notes

Note on use	The sensor does not constitute a safety component as defined by relevant legislation on machine safety.
--------------------	---

Certificates

EU declaration of conformity	✓
UK declaration of conformity	✓
ACMA declaration of conformity	✓
China RoHS	✓
cTUVus certificate	✓
Information according to Art. 3 of Data Act (Regulation EU 2023/2854)	✓

Classifications

ECLASS 5.0	27270990
ECLASS 5.1.4	27270990
ECLASS 6.0	27270913

ECLASS 6.2	27270913
ECLASS 7.0	27270913
ECLASS 8.0	27270913
ECLASS 8.1	27270913
ECLASS 9.0	27270913
ECLASS 10.0	27270913
ECLASS 11.0	27270913
ECLASS 12.0	27270913
ETIM 5.0	EC002550
ETIM 6.0	EC002550
ETIM 7.0	EC002550
ETIM 8.0	EC002550
UNSPSC 16.0901	41111615

Working range diagram

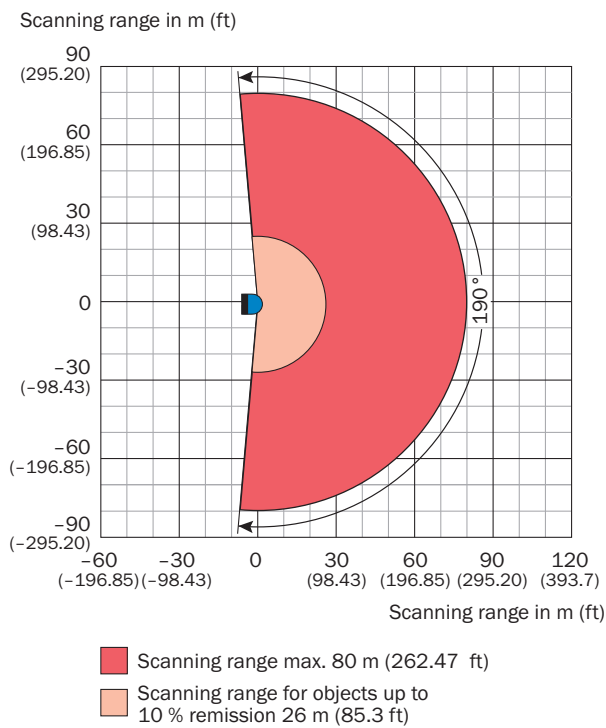

Assembly note



- ① threaded holes M8x9
- ② Mounting screws
- ③ Mounting kit 3
- ④ Mounting kit 2
- ⑤ Mounting kit 1

Assembly note

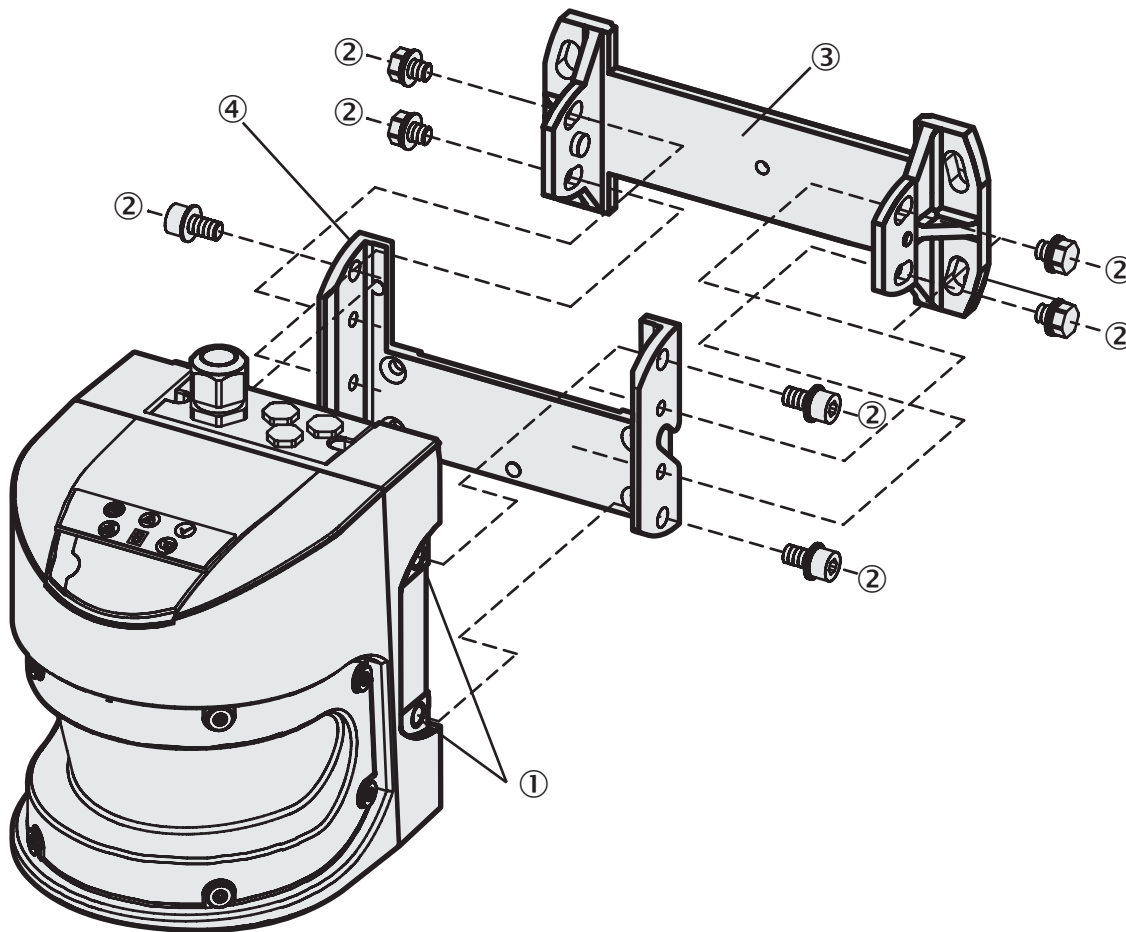

- ① threaded holes M8x9
- ② Fixing screw
- ③ Mounting kit 2
- ④ Mounting kit 1

Assembly note



- ① threaded holes M8x9
- ② Mounting screws
- ③ Mounting kit 1

Assembly note

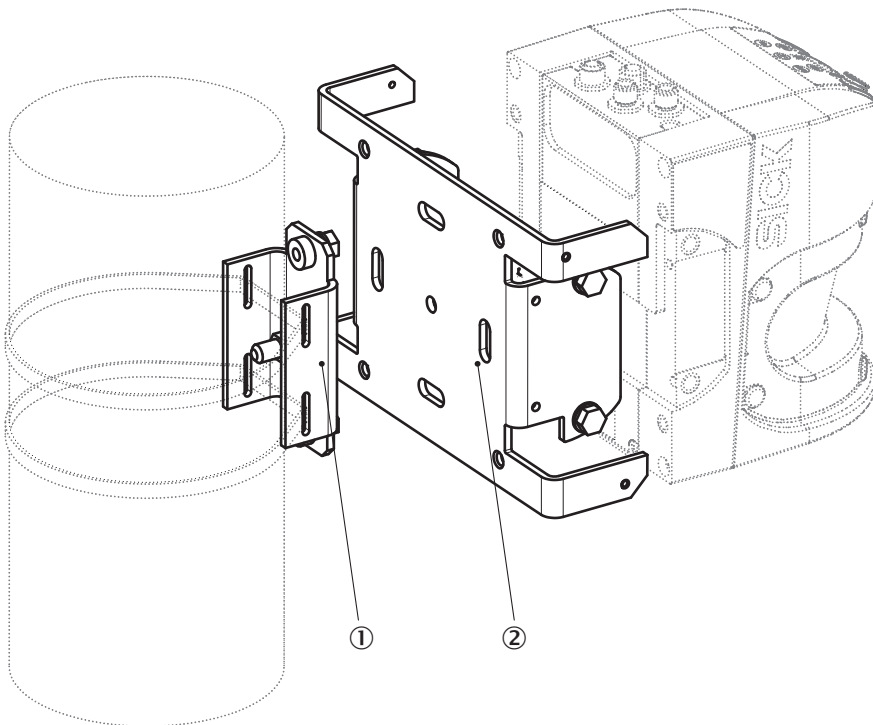

- ① Post bracket
- ② Mounting bracket 2059271

Assembly note

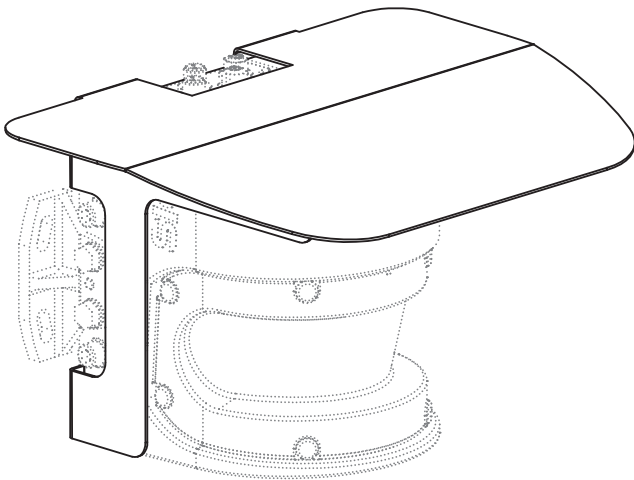

Assembly note



Assembly note



- ① Mounting bracket 2059271
- ② Mounting bracket 2018303

Assembly note

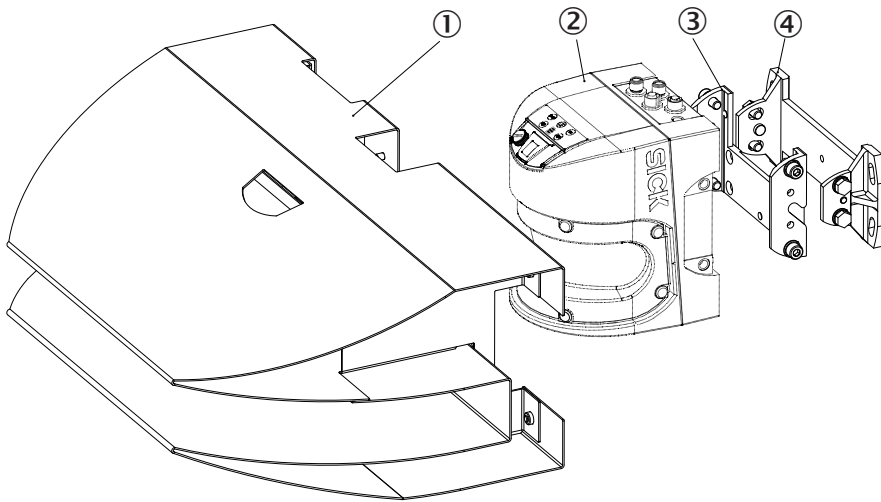

- ① Weather hood
- ② LMS5xx
- ③ Mounting kit 1
- ④ Mounting kit 2

Assembly note

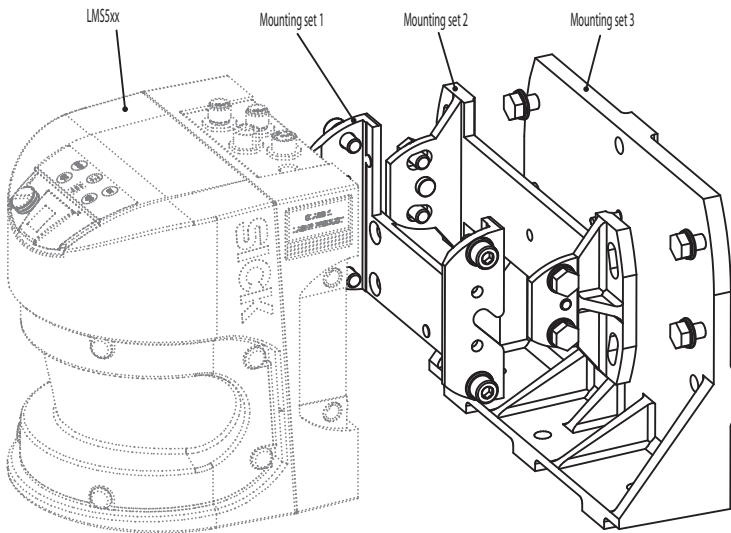

Connection type Ethernet

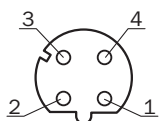

M12 female connector, 4-pin, D-coded

- ① TX+
- ② RX+
- ③ TX-

④ RX-

PIN assignment I/O

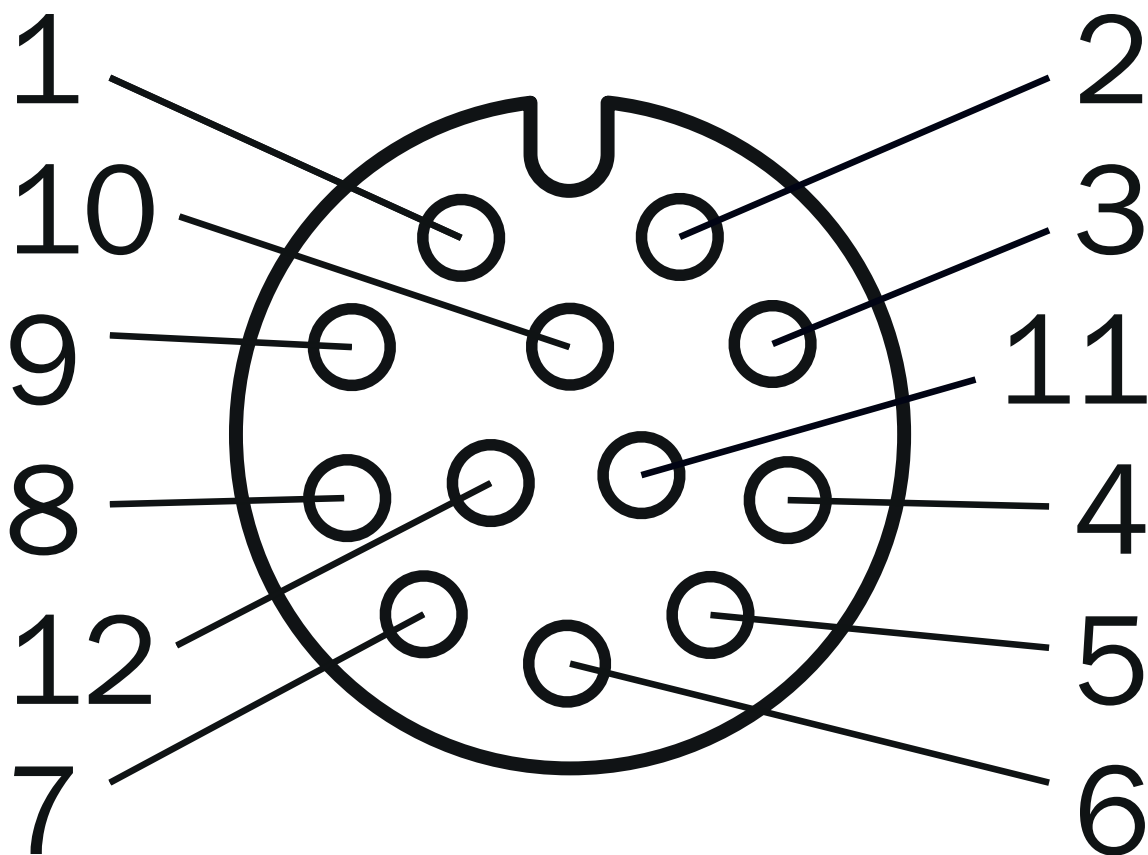

M12, 12-pin female connector, A-coded (I/O)

- ① V_s OUT
- ② GND IN1/2
- ③ In₁
- ④ GND IN3/4/IN Sync
- ⑤ In₂
- ⑥ In₃
- ⑦ GND Out 3 ... 6
- ⑧ IN4/IN Sync
- ⑨ OUT3
- ⑩ OUT4
- ⑪ OUT5
- ⑫ OUT6/OUT Sync

PIN assignment Data

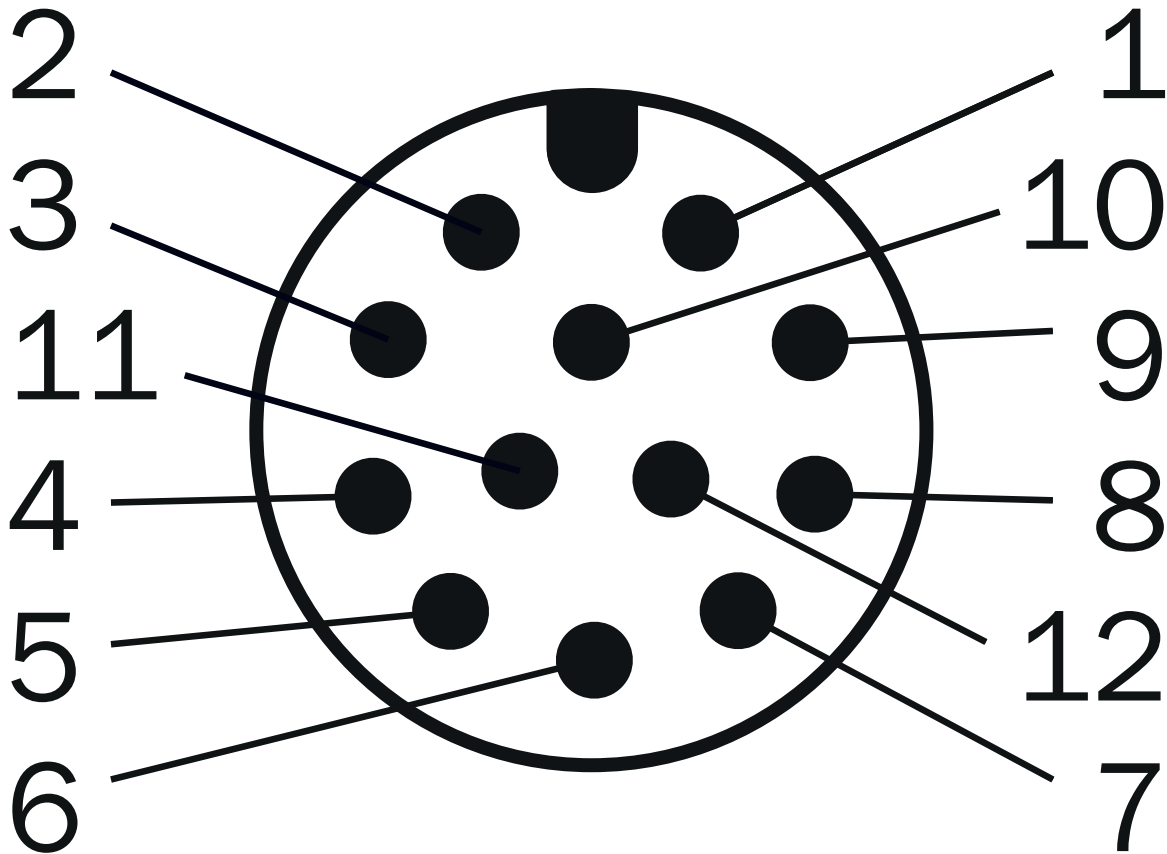

M12, 12-pin male connector, A-coded

- ① V_s OUT
- ② RD-/RxD
- ③ OUT1
- ④ GND RS/CAN
- ⑤ OUT2
- ⑥ Reserved
- ⑦ TD-/TxD
- ⑧ Reserved
- ⑨ RD+
- ⑩ TD+
- ⑪ CAN LOW
- ⑫ CAN HIGH

PIN assignment POWER connection

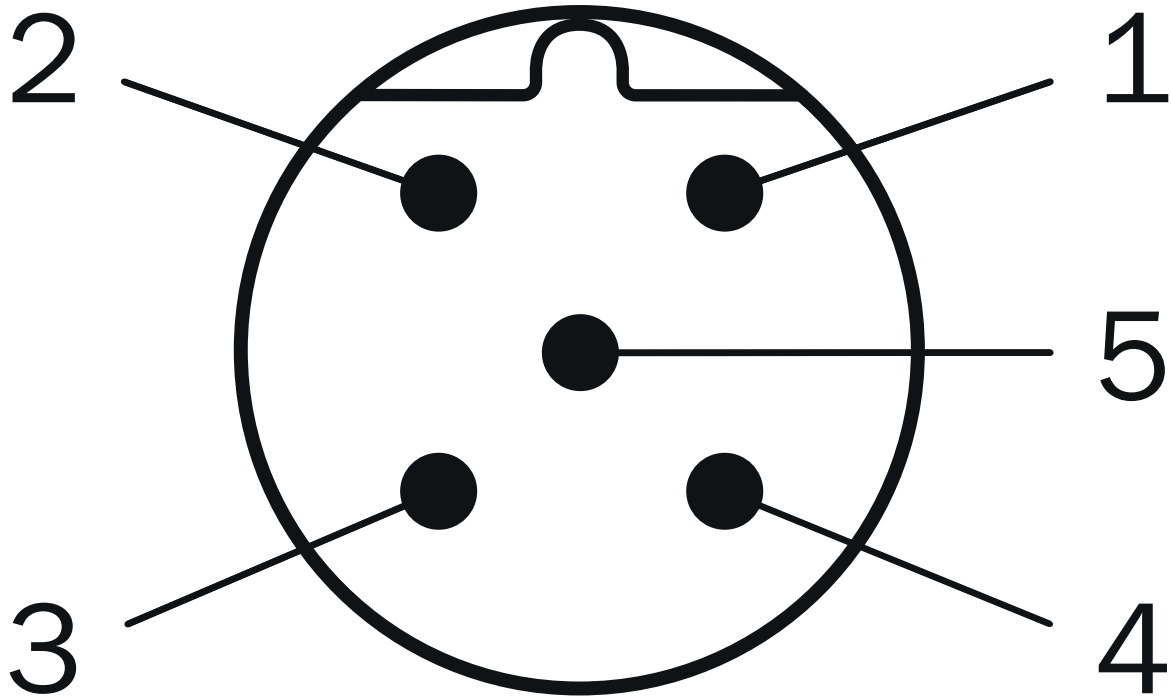







male connector M12, 5-pin, A-coded

- ① V_s
- ② V_s heat.
- ③ GND
- ④ Reserved
- ⑤ GND heat.

Recommended accessories

Other models and accessories → www.sick.com/LMS5xx

	Brief description	Type	part no.
Mounting systems			
	<ul style="list-style-type: none"> Description: Mounting bracket for direct mounting, from the rear, on wall or machine, not adjustable Material: Aluminum Details: Aluminum Packing unit: 1 piece 	Mounting kit 1	2015623
	<ul style="list-style-type: none"> Description: Mounting bracket for rear mounting on wall or machine, adjustable longitudinal and lateral axes, only in conjunction with mounting kit 1 (2015623) Material: Aluminum Details: Aluminum Packing unit: 1 piece 	Mounting kit 2	2015624

	Brief description	Type	part no.
connectors and cables			
	<ul style="list-style-type: none"> Description: Shielded Connection type head A: Female connector, M12, 4-pin, straight Connection type head B: Flying leads Cable: 5 m, 4-wire, PUR, halogen-free Application: Drag chain operation, Zones with oils and lubricants, Robot, Drag chain operation 	YF2A64-050UE1XLEAX	6054495
	<ul style="list-style-type: none"> Connection type head A: Male connector, M12, 4-pin, straight, D-coded Connection type head B: Male connector, RJ45, 4-pin, straight Signal type: Ethernet, PROFINET Cable: 5 m, 4-wire, CAT5, CAT5e, PUR, halogen-free Description: Ethernet, shielded, PROFINET Application: Cold bending resistant, Outdoor, Zones with oils and lubricants, seawater resistant 	YM2D34-050P-N4MRJA4	6054493
	<ul style="list-style-type: none"> Description: Sensor/actuator cable, shielded Connection type head A: Male connector, M12, 12-pin, straight, A-coded Connection type head B: Flying leads Signal type: Sensor/actuator cable Cable: 5 m, 12-wire, PUR, halogen-free Application: Drag chain operation, Zones with oils and lubricants, Robot, Outdoor, Outdoor 	YM2A6B-050UD3XLEAX	2131103
	<ul style="list-style-type: none"> Description: Sensor/actuator cable, shielded Connection type head A: Female connector, M12, 12-pin, straight, A-coded Connection type head B: Flying leads Signal type: Sensor/actuator cable Cable: 5 m, 12-wire, PUR, halogen-free Application: Drag chain operation, Zones with oils and lubricants, Robot, Outdoor, Outdoor 	YF2A6B-050UD3XLEAX	2131105

SICK AT A GLANCE

SICK is one of the leading manufacturers of intelligent sensors and sensor solutions for industrial applications. A unique range of products and services creates the perfect basis for controlling processes securely and efficiently, protecting individuals from accidents and preventing damage to the environment.

We have extensive experience in a wide range of industries and understand their processes and requirements. With intelligent sensors, we can deliver exactly what our customers need. In application centers in Europe, Asia and North America, system solutions are tested and optimized in accordance with customer specifications. All this makes us a reliable supplier and development partner.

Comprehensive services complete our offering: SICK LifeTime Services provide support throughout the machine life cycle and ensure safety and productivity.

For us, that is “Sensor Intelligence.”

WORLDWIDE PRESENCE:

Contacts and other locations –www.sick.com