



DATA SHEET

GLL170T-B432

GLL170
Fiber-optic sensors

SICK Sensor Intelligence

FIBER-OPTIC SENSORS

GLL170T-B432

ORDERING INFORMATION

Type	part no.
GLL170T-B432	6063340

Further device versions and accessories at www.sick.com/GLL170



Illustration may differ



DETAILED TECHNICAL DATA

FEATURES

Device type	Fiber-optic amplifier	
Device type detail	Stand-alone	
Functional principle detail	Depending on the optical fiber cable used	
Sensing range max.	Depending on the optical fiber cable used	
Emitted beam	Light source	LED ¹⁾
	Type of light	Visible red light
Key LED figures	Normative reference	EN 62471:2008-09 IEC 62471:2006, modified
	LED risk group marking	Free group
	Wave length	632 nm
	Average service life	100,000 h at T _a = +25 °C
Adjustment	Wire/pin	For setting the sensing range
	Display + operating buttons	For configuring the sensor parameters
Display	LED green	Operating indicator Static on: power on
	LED yellow	Status of digital output Permanently on: Switching output active Permanently off: Digital output not active
		Display

¹⁾ Average service life: 100,000 h at T_a = +25 °C.

SAFETY-RELATED PARAMETERS

MTTF _D	300 years
DC _{avg}	0 %
T _M (mission time)	20 years

ELECTRONICS

Supply voltage U _B	10 V DC ... 30 V DC ¹⁾																						
Ripple	≤ 10 % ²⁾																						
Current consumption	≤ 40 mA ³⁾																						
Protection class	III																						
Digital output	<table border="0"> <tr> <td>Number</td> <td>1</td> </tr> <tr> <td>Type</td> <td>PNP ⁴⁾ NPN</td> </tr> <tr> <td>Switching mode</td> <td>Light/dark switching</td> </tr> <tr> <td>Signal voltage PNP HIGH/LOW</td> <td>Approx. U_B -1.5 V / 0 V</td> </tr> <tr> <td>Signal voltage NPN HIGH/LOW</td> <td>Approx. U_B / < 1.5 V</td> </tr> <tr> <td>Output current I_{max}</td> <td>≤ 100 mA</td> </tr> <tr> <td>Circuit protection outputs</td> <td>Reverse polarity protected Overcurrent protected Short-circuit protected</td> </tr> <tr> <td>Response time</td> <td>≤ 250 μs ≤ 50 μs</td> </tr> <tr> <td>Switching frequency</td> <td>2 kHz 10 kHz</td> </tr> <tr> <td>Time functions</td> <td>Switch-on delay, off delay, one shot, Without time delay</td> </tr> <tr> <td>Delay time</td> <td>Programmable, 0 ms ... 9,999 ms</td> </tr> </table>	Number	1	Type	PNP ⁴⁾ NPN	Switching mode	Light/dark switching	Signal voltage PNP HIGH/LOW	Approx. U _B -1.5 V / 0 V	Signal voltage NPN HIGH/LOW	Approx. U _B / < 1.5 V	Output current I _{max}	≤ 100 mA	Circuit protection outputs	Reverse polarity protected Overcurrent protected Short-circuit protected	Response time	≤ 250 μs ≤ 50 μs	Switching frequency	2 kHz 10 kHz	Time functions	Switch-on delay, off delay, one shot, Without time delay	Delay time	Programmable, 0 ms ... 9,999 ms
Number	1																						
Type	PNP ⁴⁾ NPN																						
Switching mode	Light/dark switching																						
Signal voltage PNP HIGH/LOW	Approx. U _B -1.5 V / 0 V																						
Signal voltage NPN HIGH/LOW	Approx. U _B / < 1.5 V																						
Output current I _{max}	≤ 100 mA																						
Circuit protection outputs	Reverse polarity protected Overcurrent protected Short-circuit protected																						
Response time	≤ 250 μs ≤ 50 μs																						
Switching frequency	2 kHz 10 kHz																						
Time functions	Switch-on delay, off delay, one shot, Without time delay																						
Delay time	Programmable, 0 ms ... 9,999 ms																						
Pin/Wire assignment	<table border="0"> <tr> <td>Function of pin 4/black (BK)</td> <td>Digital output, received light → Output Q1 HIGH</td> </tr> <tr> <td>Function of pin 4/black (BK) – detail</td> <td>The pin 4 function of the sensor can be configured</td> </tr> <tr> <td>Function of pin 2/white (WH)</td> <td>Teach-in input</td> </tr> </table>	Function of pin 4/black (BK)	Digital output, received light → Output Q1 HIGH	Function of pin 4/black (BK) – detail	The pin 4 function of the sensor can be configured	Function of pin 2/white (WH)	Teach-in input																
Function of pin 4/black (BK)	Digital output, received light → Output Q1 HIGH																						
Function of pin 4/black (BK) – detail	The pin 4 function of the sensor can be configured																						
Function of pin 2/white (WH)	Teach-in input																						

¹⁾ Limit values.

²⁾ May not fall below or exceed U_v tolerances.

³⁾ Without load.

⁴⁾ Selectable via menu.

MECHANICS

Housing	Rectangular								
Dimensions (W x H x D)	10 mm x 31.7 mm x 72.5 mm								
Connection	Cable, 4-wire								
Connection detail	<table border="0"> <tr> <td>Deep-freeze property</td> <td>Do not bend below 0 °C</td> </tr> <tr> <td>Conductor size</td> <td>0.2 mm²</td> </tr> <tr> <td>Cable diameter</td> <td>Ø 3.8 mm</td> </tr> <tr> <td>Length of cable (L)</td> <td>2 m</td> </tr> </table>	Deep-freeze property	Do not bend below 0 °C	Conductor size	0.2 mm ²	Cable diameter	Ø 3.8 mm	Length of cable (L)	2 m
Deep-freeze property	Do not bend below 0 °C								
Conductor size	0.2 mm ²								
Cable diameter	Ø 3.8 mm								
Length of cable (L)	2 m								
Material	<table border="0"> <tr> <td>Housing</td> <td>Plastic, PC/POM</td> </tr> <tr> <td>Cable</td> <td>Plastic, PVC</td> </tr> </table>	Housing	Plastic, PC/POM	Cable	Plastic, PVC				
Housing	Plastic, PC/POM								
Cable	Plastic, PVC								
Weight	66 g								
Maximum tightening torque of the fixing screws	0.5 Nm								

AMBIENT DATA

Enclosure rating	IP66 (EN 60529)
Ambient operating temperature	-25 °C ... +55 °C
Ambient temperature, storage	-40 °C ... +70 °C
Typ. Ambient light immunity	Artificial light: ≤ 5,000 lx Sunlight: ≤ 60,000 lx
Shock resistance	50 g, 11 ms (3 positive and 3 negative shocks along X, Y, Z axes, 18 total shocks (EN60068-2-27))
Vibration resistance	10 Hz ... 55 Hz (Amplitude 1 mm, 3 x 30 min (EN60068-2-6))
Air humidity	35 % ... 95 %, relative humidity (no condensation)
Electromagnetic compatibility (EMC)	EN 60947-5-2
UL File No.	NRKH2.E300503 & NRKH8.E300503
RoHS certificate	✓

SMART TASK

Timer function	Deactivated Switch-on delay Off delay Impulse (one shot)
----------------	---

CERTIFICATES

EU declaration of conformity	✓
UK declaration of conformity	✓
ACMA declaration of conformity	✓
Moroccan declaration of conformity	✓
China RoHS	✓
China Compulsory Product Certification (CCC) exempt	✓
cRUus certificate	✓

ADJUSTMENTS GLL170T

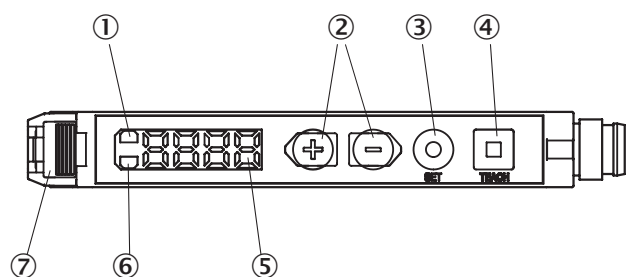

- ① LED indicator orange, lights up when switching output is active
- ② Plus/minus button
- ③ SET button
- ④ Teach-in button
- ⑤ Display
- ⑥ LED indicator green: Supply voltage active
- ⑦ Locking the fiber-optic cables

CONNECTION DIAGRAM CD-093

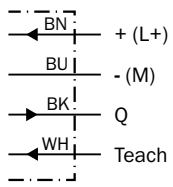

DIMENSIONAL DRAWING

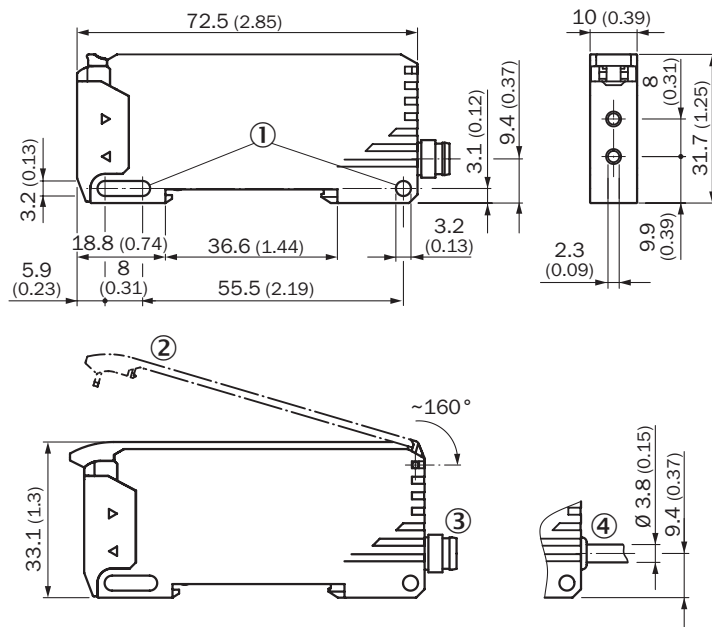

Dimensions in mm (inch)

- ① Mounting holes
- ② protective hood (optional), opens approx. 160°
- ③ Connector M8
- ④ cable

Further information as well as suitable accessories, example applications and downloads such as CAD dimensional models, operating instructions and software can be found at www.sick.com/6063340



SICK AG
WALDKIRCH
GERMANY
SICK.COM

SICK AT A GLANCE

SICK is a leading global technology company for intelligent sensors and integrated solutions in industrial automation. Our technologies set benchmarks, making your industrial processes more efficient, safer and more sustainable – both in logistics and manufacturing operations.

SICK combines sensor intelligence with industry expertise and certified consulting services. We provide the ideal foundation for scalable as well as tailor-made automation solutions and create added value along the entire value chain. Our close partnerships with our customers are more than just a promise: Together, we optimize productivity, improve quality, protect health and safety, and help build a sustainable future. All with empathy and trust.

Since 1946, we have been developing innovative technologies with passion and a pioneering spirit. With a global network in around 40 countries, SICK has a global presence and is always close by. The company's headquarters are located in Waldkirch near Freiburg, Germany. Our customers benefit from our understanding of both local and global requirements, which enables us to deliver tailor-made solutions

SICK
Sensor Intelligence