

SICK.COM



DATA SHEET

V3DU3-020RR21A

Ruler3000
3D machine vision

SICK Sensor Intelligence

3D MACHINE VISION

V3DU3-020RR21A

ORDERING INFORMATION

| Type | part no. |
|----------------|----------|
| V3DU3-020RR21A | 1135712 |

Further device versions and accessories at www.sick.com/Ruler3000



DETAILED TECHNICAL DATA

FEATURES

| | |
|-------------------------------------|--|
| Technology | 3D laser triangulation |
| Streaming | ✓ |
| Pre-calibrated | ✓ |
| Shutter technology | Global-Shutter |
| Working range | 245.5 mm ... 370.5 mm |
| Example field of view | 190 mm x 50 mm |
| Exposure mode | Linear HDR |
| Illumination | Integrated |
| Illumination color | Red, laser, Visible, 660 nm, ± 15 nm |
| Laser class | 3R (EN 60825-1:2014+A11:2021; IEC 60825-1:2014, Complies with the FDA performance requirements for laser products except for conformance with IEC 60825-1 Ed.3., as described in Laser Notice 56 dated May 8, 2019.) |
| Data synchronization | Free running, encoder triggered, external triggering |
| 3D measurement | ✓ |
| Scatter measurement | ✓ |
| Reflectance measurement | ✓ |
| Ambient light suppression | ✓ ¹⁾ |
| Scheimpflug adapter, integrated | ✓ |
| Width at minimum operating distance | 155 mm |
| Width at maximum operating distance | 220 mm |

¹⁾ Red bandpass filter.

| | |
|----------------------|--|
| Maximum height range | 125 mm |
| Task | Detecting - Standard objects Detecting - Level Measuring - Dimension, contour and volume Monitoring and controlling - Quality Determining position - 3D position determination |

¹⁾ Red bandpass filter.

MECHANICS/ELECTRONICS

| | |
|------------------------|-------------------------------------|
| Connector material | M12: Nickel-coated brass |
| Supply voltage | 24 V DC, ± 10 % |
| Ripple | < 5 V _{pp} |
| Power consumption | ≤ 12 W |
| Enclosure rating | IP65 IP67 |
| Protection class | III |
| Housing material | Aluminum |
| Housing color | Blue |
| Window material | Float glass, anti-reflective coated |
| Weight | 1.8 kg |
| Dimensions (L x W x H) | 245 mm x 65 mm x 108 mm |

PERFORMANCE

| | |
|---------------------|--|
| Image sensor | CMOS sensor from SICK with ROCC technology, M30 |
| Scan/frame rate | 46,000 3D profiles/s, In reduced ROI 7,000 3D profiles/s, full format |
| Data points/profile | 3,200 |
| Repeatability | 3.9 μm ¹⁾ |
| Typical resolution | Z resolution (height): 8 μm ... 16 μm, X resolution (width): 65 μm ... 92 μm |

¹⁾ Height values measured for different positions in the field of view. 20 measurements are performed at each position. The repeatability value is the 3-fold of the standard deviation (3 σ) for all measurements at all positions.

INTERFACES

| | |
|---|--|
| Ethernet | ✓, UDP/IP |
| Remark | GigE Vision Standard |
| Data transmission rate | ≤ 1 Gbit/s |
| Configuration software | Stream Setup |
| Operating system | Windows 10 |
| Application programming interface (API) | GenAPI, GenTL, Proprietary SICK GenIStream |
| Inputs/outputs | 4 x HIGH = 10 V ... 28.8 V, configurable |
| Encoder interface | RS-422 5 V, 2 x HTL single-ended |

AMBIENT DATA

| | |
|-------------------------------|--------------------------------------|
| Shock load | 15 g, 3 cycles per axis |
| Vibration load | 5 g, 10 Hz ... 150 Hz (EN 60068-2-6) |
| Ambient operating temperature | 0 °C ... +50 °C ¹⁾ |
| Storage temperature | -30 °C ... +70 °C ¹⁾ |

¹⁾ Non-condensing.

CERTIFICATES

| | |
|---|---|
| EU declaration of conformity | ✓ |
| UK declaration of conformity | ✓ |
| ACMA declaration of conformity | ✓ |
| China RoHS | ✓ |
| EAC certificate / DoC | ✓ |
| Information according to Art. 3 of Data Act (Regulation EU 2023/2854) | ✓ |
| GigE Vision | ✓ |
| GenICam | ✓ |

DIMENSIONAL DRAWING

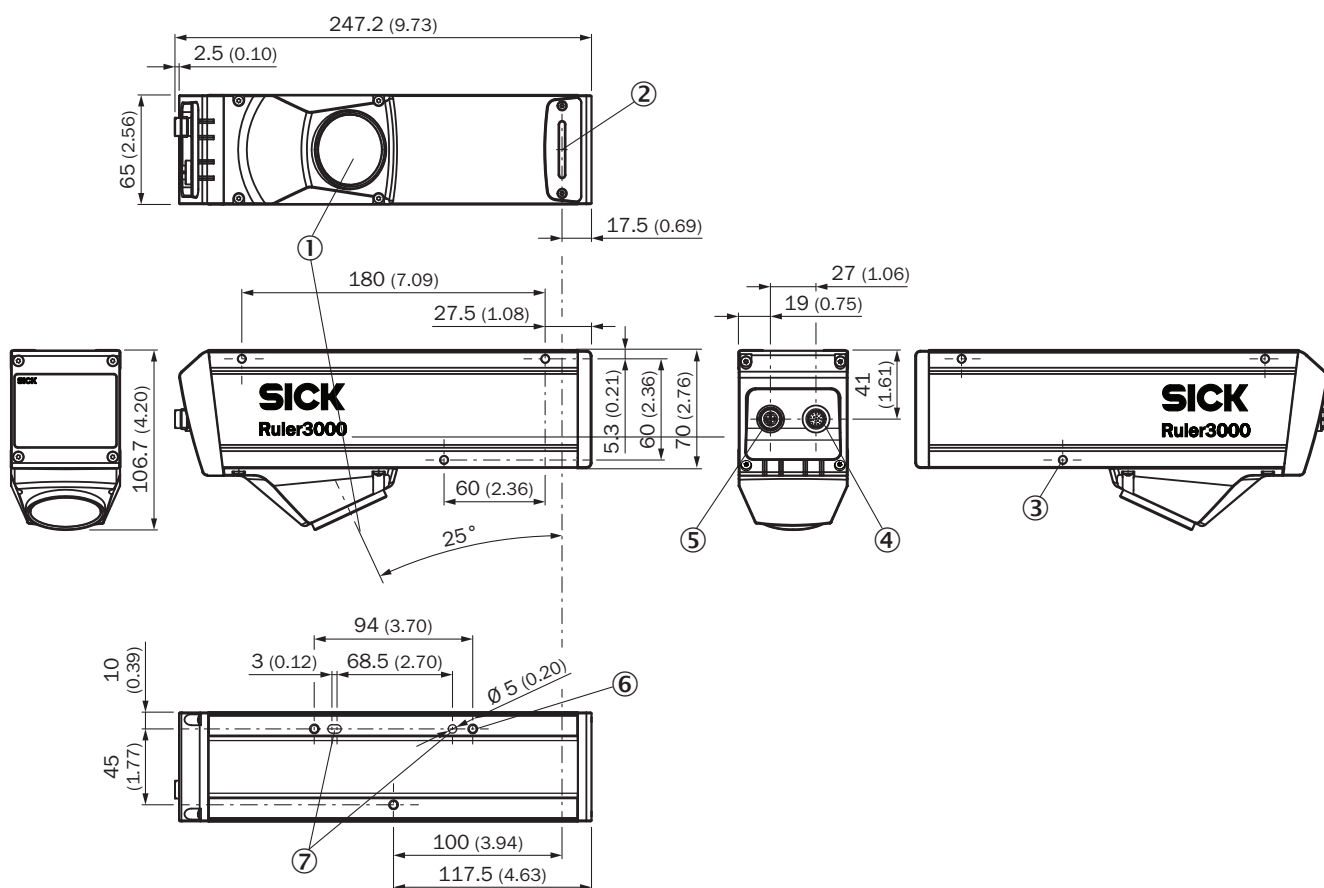

Dimensions in mm (inch)

- ① Optical receiver (center)
- ② Optical sender (center)
- ③ Threaded mounting hole (M5, 12 mm deep) with through hole ($\varnothing 4.2$ mm)
- ④ Power I/O connection
- ⑤ Gigabit Ethernet connection (GbE)
- ⑥ Threaded mounting hole (M5, 9 mm deep)
- ⑦ Position and alignment hole for locating pins ($\varnothing 5$ mm)

FIELD OF VIEW

Ruler3020

Guaranteed field of view in mm

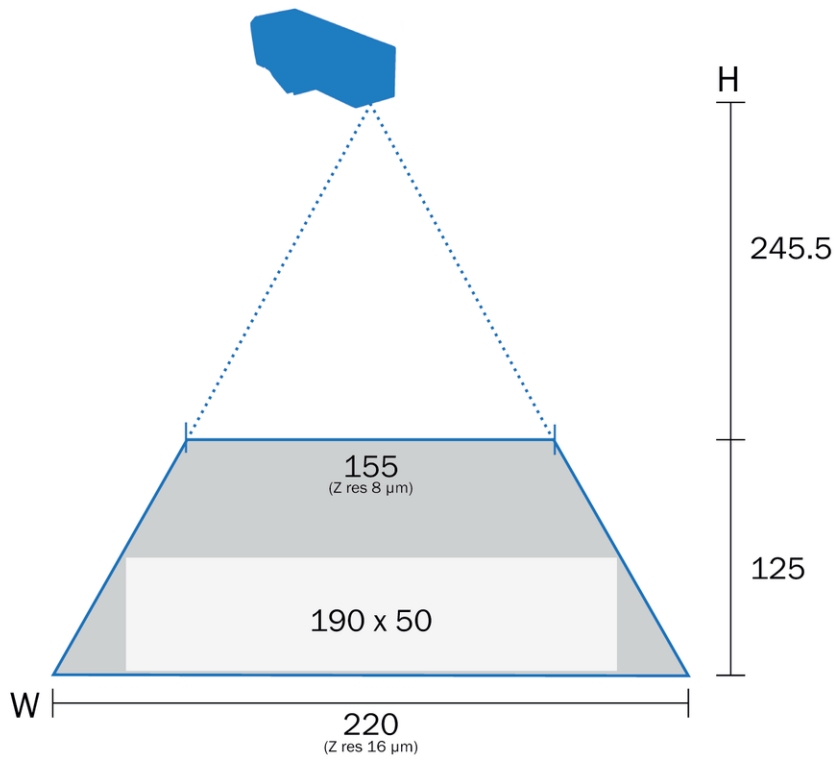

CHARACTERISTIC CURVE WIDTH OF THE FIELD OF VIEW VIA THE Z POSITION

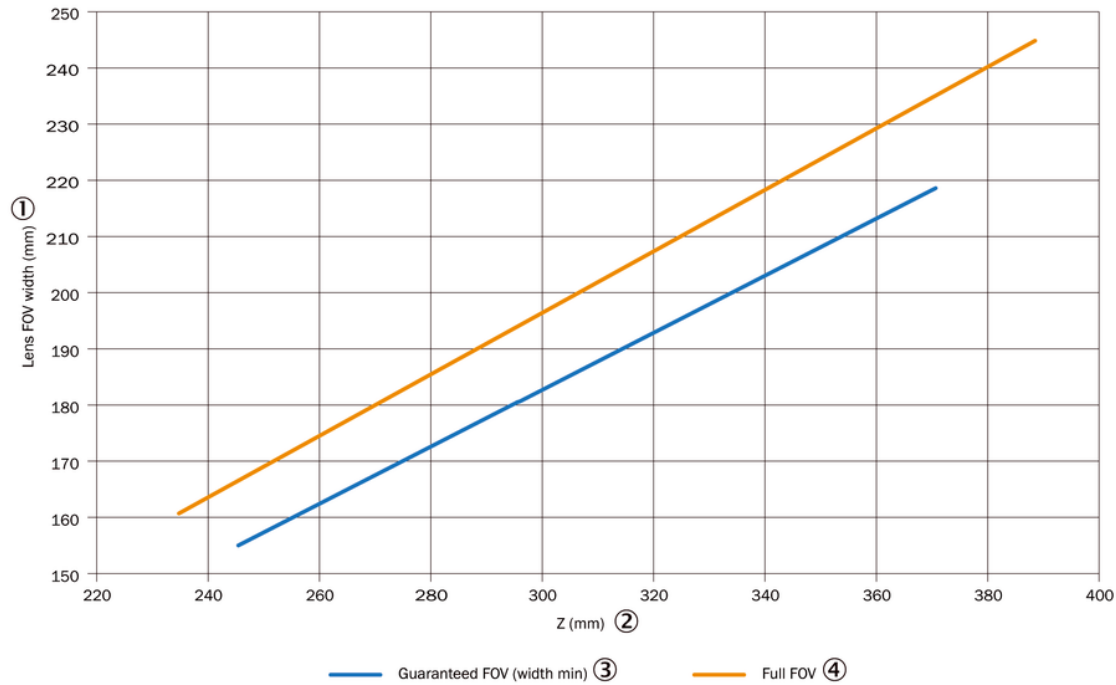

CHARACTERISTIC CURVE Z RESOLUTION VIA Z POSITION

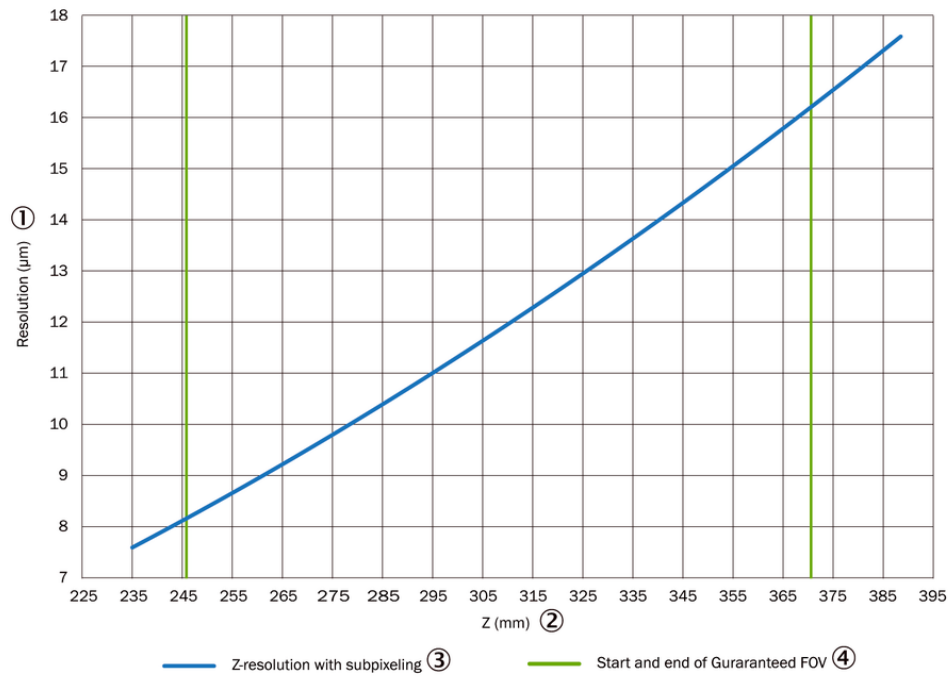

CHARACTERISTIC CURVE X RESOLUTION VIA Z POSITION

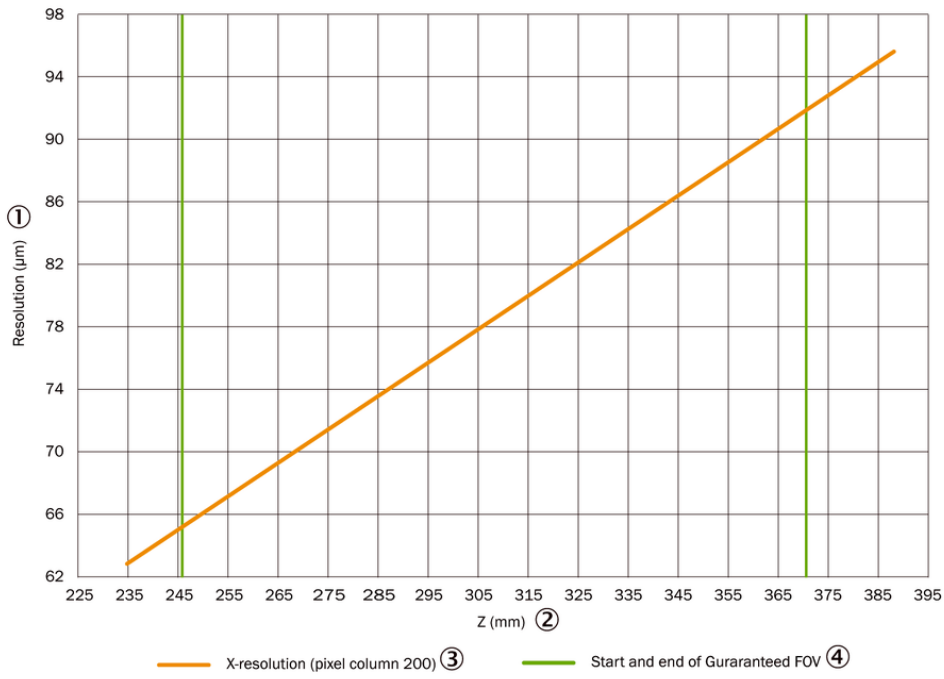

CHARACTERISTIC CURVE

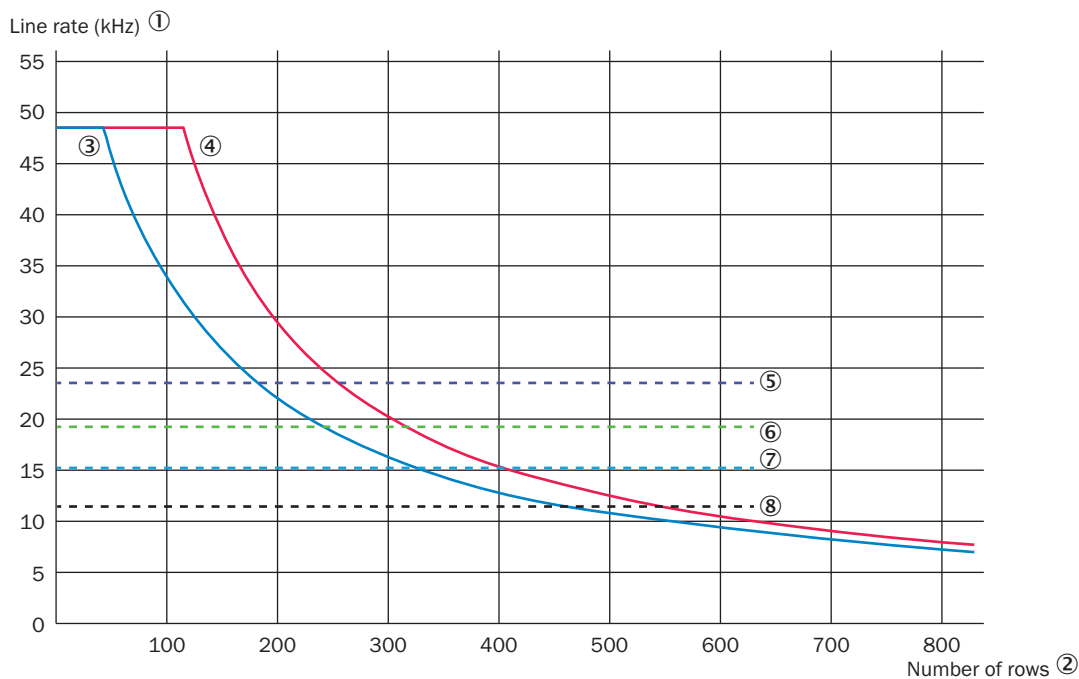

The maximum line rate is based on the number of sensor lines used

- ① Line rate (kHz)
- ② Number of lines
- ③ Ruler3000 with activated HDR
- ④ Ruler3000 without activated HDR
- ⑤ Bandwidth limit for image width 2,560, height range only
- ⑥ Bandwidth limit for image width 3,072, height range only
- ⑦ Bandwidth limit for image width 2,560, height range and reflectance
- ⑧ Bandwidth limit for image width 3,072, height range and reflectance

Further information as well as suitable accessories, example applications and downloads such as CAD dimensional models, operating instructions and software can be found at www.sick.com/1135712



SICK AG
WALDKIRCH
GERMANY
SICK.COM

SICK AT A GLANCE

SICK is a leading global technology company for intelligent sensors and integrated solutions in industrial automation. Our technologies set benchmarks, making your industrial processes more efficient, safer and more sustainable – both in logistics and manufacturing operations.

SICK combines sensor intelligence with industry expertise and certified consulting services. We provide the ideal foundation for scalable as well as tailor-made automation solutions and create added value along the entire value chain. Our close partnerships with our customers are more than just a promise: Together, we optimize productivity, improve quality, protect health and safety, and help build a sustainable future. All with empathy and trust.

Since 1946, we have been developing innovative technologies with passion and a pioneering spirit. With a global network in around 40 countries, SICK has a global presence and is always close by. The company's headquarters are located in Waldkirch near Freiburg, Germany. Our customers benefit from our understanding of both local and global requirements, which enables us to deliver tailor-made solutions

SICK
Sensor Intelligence