

AFS/AFM60S Pro

Safety encoder



Product described

AFS/AFM60S Pro

Manufacturer

SICK AG
Erwin-Sick-Str. 1
79183 Waldkirch
Germany

Legal notes

This work is protected by copyright. Any rights derived from the copyright shall be reserved for SICK AG. Reproduction of this document or parts of this document is only permissible within the limits of the legal determination of Copyright Law. Any modification, abridgment or translation of this document is prohibited without the express written permission of SICK AG.

The trademarks stated in this document are the property of their respective owner.

© SICK AG. All rights reserved.

Original document

This document is an original document of SICK AG.



Contents

1	About this document.....	6
1.1	Purpose of this document.....	6
1.2	Target group.....	6
1.3	Further information.....	6
1.4	Symbols and document conventions.....	6
2	Safety information.....	8
2.1	General advice.....	8
2.2	Intended use.....	8
2.3	Inappropriate use.....	9
2.4	Requirements for the qualification of personnel.....	9
3	Product description.....	10
3.1	Product identification.....	10
3.2	Structure and function.....	12
3.3	Interfaces.....	12
3.3.1	SSI principle of operation.....	13
3.3.2	Error memory.....	13
4	Project planning.....	14
4.1	General advice.....	14
4.2	Requirements for the mechanical shaft connection.....	14
4.2.1	Hollow shaft encoder.....	14
4.2.2	Face mount flange encoder and servo flange encoder.....	14
4.3	Requirements for the electrical connection.....	15
4.4	Requirements for signal evaluation.....	16
4.4.1	Channel 1: Sine/Cosine signals.....	16
4.4.2	Channel 2: SSI signal.....	17
4.5	Requirements on diagnostics and error detection.....	17
4.5.1	Channel 1: Vector monitoring.....	17
4.5.2	Channel 2: SSI signal.....	18
4.5.3	Channel 1 and 2: Data comparison.....	18
4.6	Consideration of encoder errors according to IEC 61800-5-2.....	18
4.6.1	Mechanical coupling of encoder housing (downtime / operation).....	18
4.6.2	Mechanical coupling of encoder shaft (downtime / operation).....	18
4.6.3	Sine/cosine signal downtime due to electrical defects.....	18
4.6.4	Measuring element (code disk) damage, contamination, or dissolving.....	18
4.6.5	Oscillation of one or more outputs.....	19
4.6.6	Swapping of the sine and cosine output signals.....	19
4.6.7	Monitoring the encoder supply voltage output by the evaluation system.....	19

4.6.8	Operating the encoder system outside the permissible temperature ranges.....	19
4.7	Testing plan.....	19
5	Mounting.....	20
5.1	General safety notes.....	20
5.2	Mounting material.....	20
5.3	Generally applicable notes.....	20
5.4	Mounting a hollow shaft encoder with a stator coupling.....	21
5.5	Mounting a hollow shaft encoder with a long stator coupling on one side.....	22
5.6	Mounting a solid shaft encoder via the threaded holes on the flange side.....	23
5.7	Mounting a solid shaft encoder with a servo flange using servo clamps.....	23
5.8	Mounting a solid shaft encoder with a servo flange using servo clamp half-shells.....	24
6	Electrical installation.....	25
6.1	Shield cover.....	25
6.2	Signals of the safety encoder.....	25
6.2.1	Singleturn.....	27
6.2.2	Multiturn.....	27
6.3	Connector and connection cable.....	28
6.3.1	M23, 12-pin.....	28
6.3.2	M12, 12-pin.....	28
6.3.3	Cable connection, 12-wire.....	29
6.4	Delivery state.....	29
7	Configuration of CW/CCW inputs and SET via hardware pin.....	30
7.1	Counting direction CW/CCW.....	30
7.2	Setting position value via SET.....	30
8	Configuration with Safety Designer.....	32
8.1	Encoder connection / Configuration tools.....	32
8.2	Installation assistant.....	33
8.3	Start.....	34
8.4	Projects.....	35
8.5	User interface.....	35
8.5.1	Menu and toolbar.....	36
8.6	User groups.....	37
8.6.1	Changing user group.....	38
8.7	Operation.....	38
8.7.1	Settings.....	38
8.7.2	Configuration.....	38
9	Commissioning.....	48
9.1	Inspection instructions.....	48

10	Maintenance.....	49
11	Troubleshooting.....	50
11.1	Diagnostics using Safety Designer.....	50
12	Decommissioning.....	51
12.1	Disposal.....	51
13	Technical data.....	52
13.1	Max. speed consideration.....	55
13.2	Dimensional drawings (all dimensions in mm).....	55
14	Ordering information.....	63
14.1	Scope of delivery.....	63
15	Accessories.....	64
16	Annex.....	65
16.1	Conformities and certificates.....	65
16.1.1	Compliance with EU directives.....	65
16.1.2	Compliance with UK statutory instruments.....	65

1 About this document

1.1 Purpose of this document

These operating instructions of the safety encoder are used to guide technical personnel working for the machine manufacturer/operator in:

- Project planning
- Configuration
- Mounting
- Electrical installation
- Commissioning
- Operation
- Maintenance

These operating instructions must be made available to everyone who works with the safety encoder .

Furthermore, planning and using safety-oriented sensors such as the safety encoder also requires technical skills that are not covered in this document.

The official and statutory requirements for operating the safety encoder must be observed at all times.

1.2 Target group

These operating instructions are intended for project developers (planners, developers, designers), installers, electricians, safety experts, operators and maintenance personnel.

They are also intended for people who integrate the safety encoder into a machine, initialize its use, or who are in charge of maintenance.



NOTICE

- ▶ Read the operating instructions carefully and ensure that you have understood the contents completely before you work with the safety encoder.
-

1.3 Further information

www.sick.com

The following information is available via the Internet:

- Data sheets
- CAD data for drawings and dimensional drawings
- Certificates (such as the EU declaration of conformity)
- Safety Designer (software for configuring the safety encoder and further safety solutions)

1.4 Symbols and document conventions

Safety notes



DANGER

A safety note informs you of real-world guidelines for safely mounting and installing the safety encoder.

This is intended to protect you against accidents.

- ▶ Read the safety notes carefully and follow them.
-

Information on property damage / general advice

**NOTICE**

Indicates important information and possible property damage.

**NOTE**

Indicates useful tips and recommendations.

Instructions

- ▶ Instructions requiring specific action are indicated by an arrow. Carefully read and follow the instructions for action.
1. The sequence of instructions for action is numbered.
 2. Follow the order in which the numbered instructions are given.

2 Safety information

2.1 General advice

The national and international laws and regulations apply to the installation and use of the safety encoder, to its commissioning, and to technical inspections repeated at regular intervals, in particular:

- MACHINERY DIRECTIVE 2006/42/EC
- Work Equipment Directive 2009/104/EC
- Work safety regulations and safety regulations
- Any other relevant safety regulations

The manufacturer and operator of the machine on which the safety encoder is used are responsible for coordinating and complying with all applicable safety specifications and regulations, in cooperation with the relevant authorities.



NOTICE

When designing the machine and, in particular, the evaluation system, the manufacturer of the machine must satisfy safety requirements which are described in these operating instructions and in the associated documents (see "[Further information](#)", [page 6](#)).

2.2 Intended use

The safety encoder can be used up to safety integrity level 3 (SIL3) in accordance with IEC 61508 or up to performance level e (PL e) in accordance with EN ISO 13849-1.

The safety encoder supports partial safety functions in accordance with IEC 61800-5-2 which are based on safety information, counting direction information and position information.

The safety encoder is not able to generate a safe machine state on its own. A higher-level evaluation system is required for this purpose.

The speed, counting direction, position and faults that could result in a hazard must be detected by a higher-level evaluation system. The requirements on the evaluation system are described in sections [section 4.4](#) and [section 4.5](#).

In order to support partial safety functions based on the safe absolute position, an additional technical measure such as a reference run during commissioning or saving the position with the evaluation system when switching off the encoder is required. These measures are also described in sections [section 4.4](#) and [section 4.5](#).



NOTICE

The safety encoder must be used within the limits of the specified technical data and operating conditions at all times. Dimensions and tolerances of the dimensional drawings as well as specified tightening torques must be complied with.

Incorrect use, improper modification or manipulation of the encoder will void any warranty from SICK AG; in addition, any responsibility and liability of SICK AG for damage and secondary damage caused thereby is excluded.

If used in any other way or if alterations are made to the device – including in the context of mounting and installation – this will render warranty claims directed to SICK AG.

2.3 Inappropriate use

The safety encoder cannot support partial safety functions that are based on the absolute position without additional technical measures.

The safety encoder is not suitable for the following applications:

- The device must not be operated under water.
- The device must not be operated in areas accessible to the public.
- The device must not be used in explosion-hazardous areas.
- Any use of accessories not specifically approved by SICK AG is at your own risk.



WARNING

Danger due to improper use!

Any improper use can result in dangerous situations. Therefore, observe the following information:

- ▶ Device should be used only in accordance with its intended use.
 - ▶ All information in these operating instructions must be strictly complied with.
-

2.4 Requirements for the qualification of personnel

The safety encoder must only be configured, installed, connected, commissioned and serviced by qualified safety personnel.

Project planning

Where project planning is concerned, a person is considered competent when he/she has expertise and experience in the selection and use of safe encoders on machines and is familiar with the relevant technical rules and national work safety regulations.

Configuration

For configuration, a person is considered qualified when he/she has the expertise and experience in the relevant field and is sufficiently familiar with the use of the safety encoder on the machine to be able to assess whether its configuration is correct.

Mechanical mounting

Where mechanical mounting and commissioning are concerned, a person is considered competent when he/she has expertise and experience in the field.

Electrical installation

Where electrical installation and commissioning are concerned, a person is considered competent when he/she has expertise and experience in the field.

Commissioning

For commissioning, a person is considered qualified when he/she has the expertise and experience in the relevant field and is sufficiently familiar with the use of the safety encoder on the machine to be able to assess whether it is functioning correctly.

3 Product description

3.1 Product identification



NOTICE

The safety encoder's year of construction can be found on the device label or on the packaging label. Keep the packaging for this reason.

Hollow shaft type code

Table 1: Hollow shaft type code

1	2	3	4	5	6	7	8	9	10	11	12	13	14	15	16	17
A	F		6	0	S	-										

Table 2: Hollow shaft type code - explanation

Position	Meaning	Description
1	-	-
2	-	-
3	Encoder design	S = Singleturn M = Multiturn
4	-	-
5	-	-
6	-	-
7	-	-
8	Type	B = Blind hollow shaft T= Through hollow shaft
9	Mechanical design	A= Hollow shaft Ø 6 mm with feather key groove B = Hollow shaft Ø 8 mm with feather key groove C = Hollow shaft Ø 3/8" with feather key groove D= Hollow shaft Ø 10 mm with feather key groove E= Hollow shaft Ø 12 mm with feather key groove F= Hollow shaft Ø 1/2" with feather key groove G= Hollow shaft Ø 14 mm with feather key groove H = Hollow shaft Ø 15 mm with feather key groove J = Hollow shaft Ø 5/8" with feather key groove ¹⁾
10	Electrical interface	K = 4.5 ... 32 V, SSI + SIN/COS S = 4.5 ... 32 V, SSI + SIN/COS, programmable
11	Connection type	A = M23 male connector, 12-pin, radial C = M12 male connector, 12-pin, radial J = Cable, 12-wire, radial 0.5 m K = Cable, 12-wire, radial 1.5 m L = Cable, 12-wire, radial 3 m M = Cable, 12-wire, radial 5 m N = Cable, 12-wire, radial 10 m

Position	Meaning	Description
12	Resolution	4 ... 262,144 number of increments per revolution, type-dependent ²⁾
13		
14		
15		
16		
17		

¹⁾ Available as a singleturn variant only.

²⁾ Number of increments per revolution of programmable devices: Singleturn between 4 ... 262144. Programmable via programming tool and Safety Designer configuration software (www.sick.com).

Solid shaft type code

Table 3: Solid shaft type code

1	2	3	4	5	6	7	8	9	10	11	12	13	14	15	16	17
A	F		6	0	S	-	S									

Table 4: Solid shaft type code - explanation

Position	Meaning	Description
1	-	-
2	-	-
3	Encoder design	S = Singleturn M = Multiturn
4	-	-
5	-	-
6	-	-
7	-	-
8	Type	S = Solid shaft
9	Mechanical design	1= Servo flange, M4 thread, solid shaft Ø 6 × 10 mm with face D = Servo flange, M4 thread, solid shaft Ø 6 × 10 mm with feather key F= Servo flange, M3 thread, solid shaft Ø 6 × 10 mm with face G = Servo flange, M3 thread, solid shaft Ø 6 × 10 mm with feather key 4= Face mount flange, M4 thread, solid shaft Ø 10 × 19 mm with face E = Face mount flange, M4 thread, solid shaft Ø 10 × 19 mm with feather key H = Face mount flange, M3 thread, solid shaft Ø 10 × 19 mm with face J= Face mount flange, M3 thread, solid shaft Ø 10 × 19 mm with feather key
10	Electrical interface	K = 4.5 ... 32 V, SSI + SIN/COS S = 4.5 ... 32 V, SSI + SIN/COS, programmable

Position	Meaning	Description
11	Connection type	A = M23 male connector, 12-pin, radial B = M23 male connector, 12-pin, axial C = M12 male connector, 12-pin, radial D = M12 male connector, 12-pin, axial J = Cable, 12-wire, radial 0.5 m K = Cable, 12-wire, radial 1.5 m L = Cable, 12-wire, radial 3 m M = Cable, 12-wire, radial 5 m N = Cable, 12-wire, radial 10 m I = Cable, 12-wire, axial 0.5 m R = Cable, 12-wire, axial 1.5 m S = Cable, 12-wire, axial 3 m T = Cable, 12-wire, axial 5 m U = Cable, 12-wire, axial 10 m
12	Resolution	4 ... 262,144 number of increments per revolution, type-dependent ¹⁾
13		
14		
15		
16		
17		

¹⁾ Number of increments per revolution of programmable devices: Singleturn between 4 ... 262144. Programmable via programming tool and Safety Designer configuration software (www.sick.com).

3.2 Structure and function

The AFS/AFM60S Pro safety encoder is a high-resolution safety encoder with a diameter of 60 mm.

The encoder information is transferred to the evaluation system via dual-channels:

- Channel 1: Output of analog signals in the form of sine/cosine-wave voltages
- Channel 2: Provides an SSI interface

If a suitable evaluation system is used, the safety encoder can be used for partial safety functions in accordance with IEC 61800-5-2 which are based on counting direction, speed and absolute position.

In accordance with IEC 61800-5-2, the mechanical interface has been dimensioned in such a way that it is possible to assume errors are ruled out based on its over-dimensioning.

3.3 Interfaces

The safety encoder is equipped with an SSI+SinCos interface. The combination of the synchronous serial interface (SSI) with the sine-shaped analog output (SinCos) makes it possible to transmit both absolute position data and speed information.

The synchronous serial interface (SSI) was originally developed by Max Stegmann GmbH (now SICK). The SSI is an interface for serial data transmission which enables complete position information.

3.3.1 SSI principle of operation

- The current position value of the encoder is continuously loaded into a shift register.
 - The controller (SSI master) requests a position value by transmitting a clock sequence on the CLOCK cable to the encoder (SSI slave). The number of cycles depends on the word width to be transmitted or the set resolution.
 - The first edge falling over the CLOCK cable activates a monostable multivibrator in the encoder which switches the shift register from loading of the position value to serial output of the position value.
 - For each rising clock edge which follows, a data bit beginning with the highest value bit and ending with the lowest value bit is transmitted to the control via the DATA cable from the encoder.
 - Via the clock sequence, the monostable multivibrator is continuously re-triggered, which prevents reloading of a position value into the shift register during ongoing transmission.
 - After the clock sequence has ended, the monostable multivibrator is no longer re-triggered, the DATA cable is held at the low level until the monoflop time has expired, then it switches the shift register back to the output state, thereby enabling reloading of the current position value.
- If a new clock sequence is started within the monoflop time, a defective data transfer occurs (monoflop time $\leq 25 \mu\text{s}$), which can be detected as per the measures in [section 4.4](#). To ensure a valid position information, the monoflop time must be adhered to.

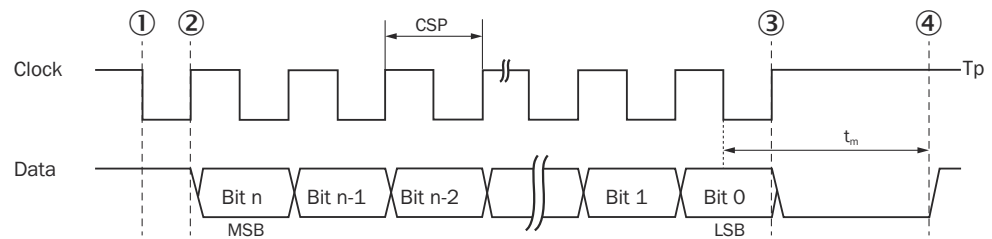

Figure 1: SSI principle of operation - detailed view

- ① The position is loaded to the shift register.
- ② Transmission of the first (highest value) data bit.
- ③ All data bits are transmitted, monostable multivibrator is no longer re-triggered.
- ④ Monostable multivibrator time has expired, shift register switches to the output state. The current position can be loaded back to the shift register. New transmission can begin.

CSP	Period duration of the clock
T_m	Monoflop time $\leq 25 \mu\text{s}$
MSB	Most significant bit
LSB	Least significant bit
T_p	Clock break

3.3.2 Error memory

The AFS/AFM60S Pro monitors whether the encoder is functioning properly as well as environmentally-specific parameters such as temperature and voltage supply with internal diagnostics. Possible errors are then saved in an internal error memory.

Up to 10 errors can be stored. The same types of errors are counted up. The errors are saved in accordance with their significance. If the error memory is full, errors with low significance are overwritten.

Critical errors are kept and not overwritten ([see "Diagnostics", page 44](#)).

4 Project planning

4.1 General advice

IP protection

The defined IP protection level of the device is ensured on the device side by the cable gland or the M12 or M23 male connector of the encoder. The assembled and mounted cable end must fulfill the same IP protection as the device itself in order to fulfill the IP protection of the overall unit. Unsealed areas on the open end or an improperly fastened cable end can reduce or make ineffective the IP protection of the overall unit, e.g. due to the capillary effect (responsibility of the operating entity).

Mechanical self-heating

The safety encoder is subject to a self heating of approx. 3.0 K / 1,000 min⁻¹. Both the thermal loads of the application and the self-heating of the safety encoder need to be taken into consideration when determining the permissible ambient temperature. The temperature at the operating temperature measuring point (see ["Dimensional drawings \(all dimensions in mm\)", page 55](#)) must not exceed the permissible operating temperature range (see ["Technical data", page 52](#)). Exceeding the operating temperature range can lead to errors being reported and therefore reduced availability.

4.2 Requirements for the mechanical shaft connection

4.2.1 Hollow shaft encoder

The drive unit must be connected to the hollow shaft encoder using a high force clamp connection or a form-fit and a high force clamp connection. Using a feather key prevents slip between the encoder shaft and drive shaft.

A feather key must be used for drive shafts with a diameter of 6 mm, 8 mm, and 3/8". This ensures the over-dimensioning required to rule out errors caused by the shaft connection.

- To find out the requirements for mounting the feather key on the drive shaft, refer to the dimensional drawings, see ["Dimensional drawings \(all dimensions in mm\)", page 55](#). The material from which the customer-supplied drive shaft is made must have a tensile strength of at least 530 N/mm².



NOTICE

Violation of measurement accuracy caused by vibrations and shocks

In the hollow shaft variant of the AFx60S, the stator coupling creates a spring-mass-system together with the male device connector or the cable outlet which oscillates when stimulated (e.g. due to vibrations), therefore causing torsion of the encoder housing.

Since the relation between the encoder housing and shaft determines the measured value, violations of the specified accuracies of the position value (i.e. also safety-related accuracy) can occur under these conditions.

- ▶ Stimulation of the system caused by vibrations in the resonance range and shocks must be reliably ruled out in the application.
-

4.2.2 Face mount flange encoder and servo flange encoder

The shaft coupling is part of the safety-related function chain and must be dimensioned and validated accordingly by the user. It is not an integral part of the safety assessment carried out by SICK AG.

- ▶ Connect encoder shaft and drive shaft via a coupling.
- ▶ Use a coupling that is suitable for the application. Couplings must comply with the requirements of IEC 61800-5-2:2016. Observe the technical data and mounting instructions of the coupling used.
- ▶ Observe the requirements on the flange connection in accordance with the information in the product information.

(see "Dimensional drawings (all dimensions in mm)", page 55):

- Solid shaft with feather key
- Solid shaft with face

4.3 Requirements for the electrical connection

- ▶ Supply the encoder with the supply voltage which is generated from PELV systems (EN 50178) (degree of contamination 2).
- ▶ Limit the power supply unit current used for the encoder to a maximum continuous current of 1 A, either by the power supply itself or using a fuse.



NOTICE

- ▶ Observe when designing the power supply unit [figure 2](#).

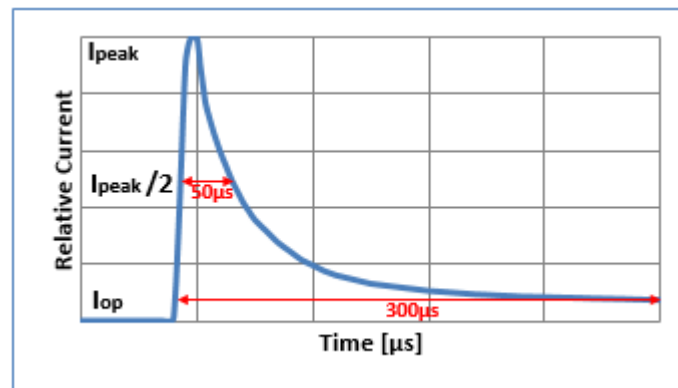

Figure 2: Behavior of the switch-on current

The maximum switch-on peak I_{peak} is 2 A at $U_S = 4.5$ V and 20 A at $U_S = 32$ V. After a maximum of 50 μs , the switch-on current goes back to half $I_{peak} / 2$ and the operating current I_{op} sets in after 300 μs .

- ▶ Ensure that the supply voltage of +4.5 V to +32 V is present on the M23 male connector or cable connection, or +4.5 V to +30 V on the M12 male connector on the corresponding pins or wires of the encoder.
- ▶ Perform differential evaluation of the encoder signals.
- ▶ Terminate used and unused safety encoder signals differentially; i.e., insert a terminating resistor of $\geq 120 \Omega$ between the signal and the complementary signal.
- ▶ In safety encoders with a connector outlet, do not pass on unused signals. Terminating is not required here.
- ▶ Only use screened and twisted-pair cables. All signal cables/interface signals must be twisted in pairs with the appropriate complementary signal.
- ▶ Protect the stator coupling against any strain caused by the connecting cables. Observe the smallest permitted bend radius of the connecting cables (permitted bend radius for safety encoder with cable connection: min. $10 \times$ outer diameter of the cable).
- ▶ Use a cable that is suitable for the application and the application conditions.



NOTE

We recommend that you use SICK accessory cables (see corresponding data sheets).

4.4 Requirements for signal evaluation

The differential signals must always be used to evaluate the signals (see "Signals of the safety encoder", page 25).

To use all the partial safety functions provided, both the sine and cosine signals (channel 1) and the SSI signal (channel 2) must be evaluated.

Channel 1 and channel 2 must be evaluated separately with a suitable safety architecture.

The safety signals from channel 1 (sine and cosine signals) can be used on their own (without also considering the SSI signals from channel 2) for speed-based partial safety functions. In this case the applicable diagnostics and fault detection requirements (section 4.5) must be implemented for channel 1. This ensures that the safety signals from channel 1 will meet the requirements for PLe/Cat. 3 in accordance with EN ISO 13849-1, or SIL3 in accordance with IEC 61508.

4.4.1 Channel 1: Sine/Cosine signals

Relative position

Square-wave signals must be formed from the differential signals using suitable switching elements (e.g., comparators). These square wave signals are used for counting by means of appropriate methods (e.g., a quadrature decoder).

The switching thresholds must be selected so that the lower limit of the vector length monitoring (see "Channel 1: Vector monitoring", page 17) is not exceeded. Accordingly, the upper switching threshold – including tolerance – must be a maximum of 150 mV above the center of the signal (see figure 11) and the lower switching threshold – including tolerance – must be a maximum of 150 mV below the center of the signal.



NOTICE

If the switching thresholds are not dimensioned appropriately and hysteresis occurs during signal evaluation, this can cause additional signal edges to be detected incorrectly or an incorrect failure to detect signal edges. This can lead to the counting direction, position, or speed being determined incorrectly, for example.

Using the counter, it is possible to achieve a resolution of 4,096 steps per rotation (i.e., 4 steps per signal period or 1 step per quadrant of each signal period).

An incrementally counted position can be generated based on the counter.

The counting direction and speed can be determined from the change from this counted relative position.

Absolute position

For an absolute position with channel 1, the evaluation unit requires an independent initial start position in addition to the counters. The start position must not be removed from the SSI channel, but be dependent on it.



NOTICE

At no time may the counted position of channel 1 be based on the SSI position of channel 2. The independence of the channels must be guaranteed at all times.

1. Determine the start position during commissioning, e.g. with a reference run.
2. Initiate the counted position with the defined start position.
3. During or before switching off, save the counted position in the evaluation unit.
4. When starting up the next time, compare the saved position with the absolute position of channel 2 (SSI position).

Only if the defined deviation is smaller than that permitted in the application (e.g. within the permitted safety-related accuracy) can the absolute position be used for safety purposes. If the deviation is larger, a corresponding error reaction must take place in the evaluation system. In this case, a new start position must be defined for initialization of the counted position of channel 1, e.g. with a reference run.

4.4.2 Channel 2: SSI signal

Absolute position

If an encoder detects an error, the error status is displayed to the evaluation system by the SSI channel only outputting "1", whereby the error bits (see "Singleturn", page 27) are set.

The evaluation system must evaluate at least one error bit for error detection.

4.5 Requirements on diagnostics and error detection

The evaluation unit has the safety-related function of detecting errors in the safety encoder signals and to execute reactions during the process safety time in the event of an error in order to prevent dangerous situations. The process safety time is the period of time between the point at which a failure of the measurement system that could cause a hazard occurs, and the point by which the reaction must be complete in order to avoid this hazard, to bring the machine to a safe state or to ensure/keep it there.

The diagnostics described in sections [section 4.5.1](#), [section 4.5.2](#) and [section 4.5.3](#) must be carried out within the process safety time.

The sum of the maximum time required for error detection and the time for responding to errors must be less than the process safety time.¹⁾

The maximum time required for error detection is the interval during which the diagnostic measures listed below are repeated in full.

4.5.1 Channel 1: Vector monitoring

To detect all impermissible level changes in the relationship between sine and cosine, the underlying mathematical relationship between sine and cosine signals is used.

By finding the variable k using the following mathematical formula or another suitable mathematical process, it is possible to determine the common DC voltage level of both the sine and cosine signals:

$$k^2 = k1^2 \times \sin^2\alpha + k2^2 \times \cos^2\alpha$$

Comparing this with the corresponding maximum and minimum limits enables impermissible deviations to be detected quickly and precisely, regardless of the current angular position α .

The signals available can be used to determine k on the basis of the following calculation:

$$k^2 = (\text{SIN+} - \text{SIN-})^2 + (\text{COS+} - \text{COS-})^2$$

¹⁾ Process safety time: Period of time between the point at which a malfunction that could cause a hazard occurs, and the point by which the reaction must be complete in order to avoid this hazard.

This relationship between the useful signals can be illustrated clearly using a two-dimensional model (Lissajous diagram). In this case, the useful signals form a useful signal ring.

Where the signal k is concerned, a tolerance of $\pm 50\%$ is permitted on either side of the nominal position. A deviation that is greater than this indicates a violation of the vector length limits. The evaluation system must respond to the error accordingly.

To avoid false triggering, we recommend that you do not make the limits too restrictive.

4.5.2 Channel 2: SSI signal

The SSI signal must be investigated for at least 1 set error bit during each request. If at least 1 error bit is set, an error has occurred and the evaluation unit must initiate a respective error reaction within the process safety time.

4.5.3 Channel 1 and 2: Data comparison

The information (counting direction, speed, position) determined from both channels (channel 1: Sin/Cos, channel 2: SSI) must be compared within the process safety time:

1. Determine the counted position of channel 1 (sin/cos signals).
2. Determine position of channel 2 (SSI signal).
3. Compare positions to determine their deviation.
4. Compare the determined deviation with the permissible deviation.

Only if the defined deviation is smaller than that permitted in the application (e.g. within the permitted safety-related accuracy) may the information be used for safety purposes. If the deviation is larger, a corresponding error reaction must take place in the evaluation system.

Synchronization of SSI and SinCos

Depending on the clock time (baud rate), the number of bits transmitted (position and error bits), and the monoflop time, deviations can arise between the serial SSI interface (channel 2) and the analog SinCos interface (channel 1). The SSI position is obtained from the first falling edge of the SSI clock signal (see ["Interfaces", page 12](#)).

4.6 Consideration of encoder errors according to IEC 61800-5-2

4.6.1 Mechanical coupling of encoder housing (downtime / operation)

In accordance with IEC 61800-5-2, this error assumption can be ruled out if the stator coupling or the face mount flange/servo flange has been mounted correctly (see ["Mounting", page 20](#)).

4.6.2 Mechanical coupling of encoder shaft (downtime / operation)

In accordance with IEC 61800-5-2, this error assumption can be ruled out if the encoder has been mounted correctly on the drive shaft (see ["Mounting", page 20](#)).

4.6.3 Sine/cosine signal downtime due to electrical defects

This error assumption can be ruled out as sine/cosine signals are detected and processed in a purely analog manner, and the design does not provide for any memory structures for analog voltages.

4.6.4 Measuring element (code disk) damage, contamination, or dissolving

Damage to or contamination on the measuring element can lead to the following situations:

A loss of sender masking will result in the maximum signal level being reached on both channels. This can be identified in accordance with [section 4.5](#) .

If the code disk is not aligned correctly in relation to the optical scanner or if contamination is present, this will also result in a signal level on the sine and cosine channels, which can be diagnosed according to [section 4.5](#) .

In accordance with EN ISO 13849-1 and EN ISO 13849-2, errors that occur as a result of the code disk loosening can be ruled out due to mechanical over-engineering.

4.6.5 Oscillation of one or more outputs

Oscillation at the signal outputs can be detected as follows:

If the oscillation leads to impermissible signal levels in one or both channels, then error detection as per [section 4.5](#) can be used.

During downtime, and when using a suitable phase discriminator for generating counting pulses in the evaluation system, oscillation of an input signal will result in counting up and down for an increment. The error resulting from this corresponds to the angular value of one increment.

Oscillation of both signals (sine and cosine) in the phase or of an individual signal while the motor is running will lead to impermissible signal levels which are detected using measures in accordance with [section 4.5](#) .

4.6.6 Swapping of the sine and cosine output signals

This error can be ruled out as the sine/cosine signals are detected and processed separately. The encoder does not use any multiplexers for these signals.

4.6.7 Monitoring the encoder supply voltage output by the evaluation system

Impermissible encoder supply voltage levels are detected using the measures in accordance with [section 4.5](#) .

The lower limit for the vector length specified there is particularly useful for undervoltage monitoring. The encoder supply voltage is also monitored in the encoder. Impermissible voltage levels lead to an error message in the SSI signal.

4.6.8 Operating the encoder system outside the permissible temperature ranges

The encoder temperature is monitored in the encoder. Impermissible temperatures lead to an error message in the SSI signal.

4.7 Testing plan



NOTICE

The safety encoder must be tested by appropriately qualified safety personnel when commissioning, after modifications, and at regular intervals.

The regular thorough checks serve to verify the effectiveness of the safety encoder and discover defects due to modifications or external influences (such as damage or manipulation).

The manufacturer and user must define the type and frequency of the thorough checks on the machine on the basis of the application conditions and the risk assessment.

Determination of the thorough checks must be documented in a traceable manner.

5 Mounting

5.1 General safety notes

WARNING

Risk of injury from electrical voltage

- ▶ Make sure the affected machines / systems / vehicles are in a de-energized state before mounting!

NOTICE

Any shocks or impact to the shaft / device must not exceed the specified impact values; this could damage the ball bearings.

NOTICE

The permissible axial and radial forces must not be exceeded.

NOTICE

If the operating temperatures at the measuring point exceed 50 °C, the “HOT SURFACE” warning must be attached to the device.

5.2 Mounting material

You will need the following screws:

Mounting	Material
Stator coupling	4 × M3 cheese-head screws in accordance with ISO 4762 (or equivalent screw types with even connecting surface) Washers
Flange variants F, G, H, J	3 × M3 screws
Flange variants 1, D, 4, E	3 × M4 screws
Servo flange assembly	Servo clamp half-shell accessory set (part 2029165) / 4 × M4 screws Large servo clamp accessory set (part no. 2029166) / 3 × M4 screws

The property class of the screws must be at least 8.8. Select the length of the screws in accordance with the installation conditions.

5.3 Generally applicable notes

Mounting specifications

The mounting directions and tolerances must be executed in accordance with the manufacturer specifications.

The more precise the centering for the encoder, the lower the angle and shaft offset during mounting and the lower the load on the bearings of the encoder.

- ▶ All screw connections must be secured against loosening with liquid screw adhesive (LOCTITE 243, for example).

NOTICE

Spring washers and toothed washers are not sufficient for securing screws.

- All mounting surfaces should have a contact surface pressure $> 200 \text{ N/mm}^2$.
- For variants with a stator coupling, the entire stator coupling must lie flat on the mounting surface.
- All fixing screws should not exceed a screw-in depth of 5 threads.

For variants with a stator coupling, it may not be possible to hold the torque wrench perpendicular to the screw. An angle of inclination of up to 20° is included in the tightening torque tolerance. Loosening or fixing the screw at an angle on a regular basis can cause damage to the screw (see sections [section 5.4](#) and [section 5.5](#)).



NOTICE

The encoder must not be mounted with double elasticity (either stator or shaft coupling).

If the connections are form-fit, ensure that the parts to be mounted are free of lubricants and contaminations.

5.4 Mounting a hollow shaft encoder with a stator coupling

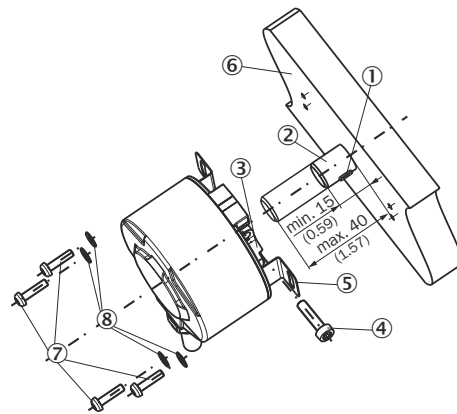

Figure 3: Mounting a blind hollow shaft encoder

- ① Feather key
- ② Operator-side drive shaft
- ③ Clamp ring
- ④ Torx screw T20
- ⑤ Stator coupling distance
- ⑥ Mounting surface
- ⑦ Screw
- ⑧ Washer

Pre-installation steps

- If necessary, mount the feather key on the drive shaft provided by the customer (observe section [section 4.2.1](#)).

Mounting

1. Apply screw adhesive (observe section [section 5.3](#)) to the thread of the clamping ring or the supplied Torx screw T20.
2. Insert the Torx screw in the clamping ring and secure it loosely; do not tighten it at this stage.
3. Push the encoder onto the customer drive shaft, aligning it with the feather key.
4. Secure the screws and the washers loosely and apply screw adhesive (observe section [section 5.3](#)) to each thread at the same time.

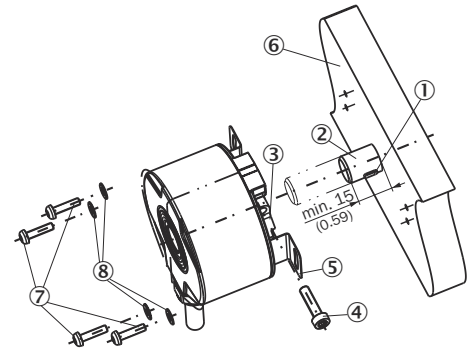

Figure 4: Mounting a through hollow shaft encoder

- ① Feather key
- ② Operator-side drive shaft
- ③ Clamp ring
- ④ Torx screw T20
- ⑤ Stator coupling distance
- ⑥ Mounting surface
- ⑦ Screw
- ⑧ Washer

5. Screw in the screws until the encoder can be fully pushed on and the stator coupling is resting against the mounting surface.
6. Align and block the drive provided by the customer in line with the mounting conditions, i.e. the accessibility of the screw.
7. Tighten the screw; tightening torque: 1.2 ± 0.1 Nm.
8. Tighten the Torx T20 screw on the clamping ring, tightening torque: 3.5 ± 0.1 Nm.

5.5 Mounting a hollow shaft encoder with a long stator coupling on one side

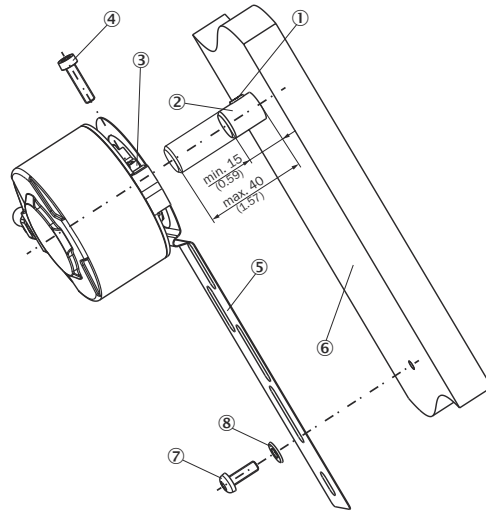

Figure 5: Mounting a blind hollow shaft encoder with a long stator coupling on one side

- ① Feather key
- ② Operator-side drive shaft
- ③ Clamp ring
- ④ Torx screw
- ⑤ Stator coupling, long
- ⑥ Mounting surface
- ⑦ Screw
- ⑧ Washer

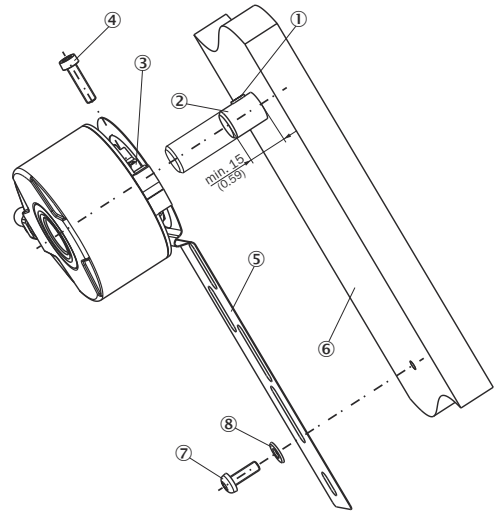

Figure 6: Mounting a through hollow shaft encoder with a long stator coupling on one side

- ① Feather key
- ② Operator-side drive shaft
- ③ Clamp ring
- ④ Torx screw
- ⑤ Stator coupling, long
- ⑥ Mounting surface
- ⑦ Screw
- ⑧ Washer

Pre-installation steps

- If necessary, mount the feather key on the drive shaft provided by the customer (observe section [section 4.2.1](#)).

Mounting

1. Apply screw adhesive (observe section [section 5.3](#)) to the thread of the clamping ring or the supplied Torx screw T20.
2. Insert the Torx T20 screw in the clamping ring and secure it loosely; do not tighten it at this stage.
3. Push the encoder onto the customer drive shaft, aligning it with the feather key so that the long stator coupling is resting against the mounting surface.
4. Mount the long stator coupling using at least one M4 screw and a washer, and apply screw adhesive (observe section [section 5.3](#)) to each thread at the same time.
5. Align and block the drive provided by the customer in line with the mounting conditions, i.e. the accessibility of the screw.
6. Tighten the screw; tightening torque: 1.2 ± 0.1 Nm.
7. Tighten the Torx T20 screw on the clamping ring, tightening torque: 3.5 ± 0.1 Nm.

5.6 Mounting a solid shaft encoder via the threaded holes on the flange side

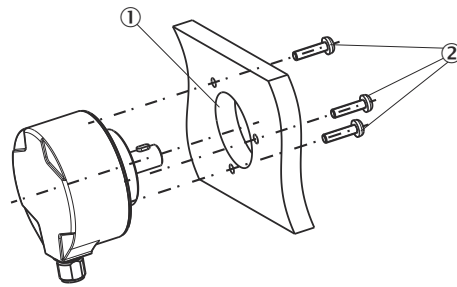

Figure 7: Mounting a face mount flange using threaded holes on the flange side

- ① Centering collar
- ② Screws

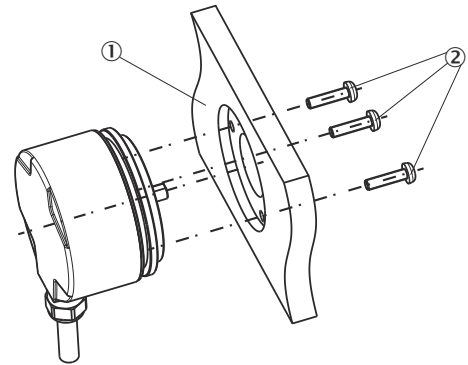

Figure 8: Mounting a servo flange using threaded holes on the flange side

- ① Centering collar

1. Insert the encoder into the centering collar.
2. Mount the screws and apply screw adhesive (observe section [section 5.3](#)) to each thread at the same time.
3. Tighten the screws; tightening torque: 1.2 ± 0.1 Nm.
4. Create a shaft connection between the encoder and the drive shaft using a suitable, flexible connection (observe section [section 4.2.2](#)).

5.7 Mounting a solid shaft encoder with a servo flange using servo clamps

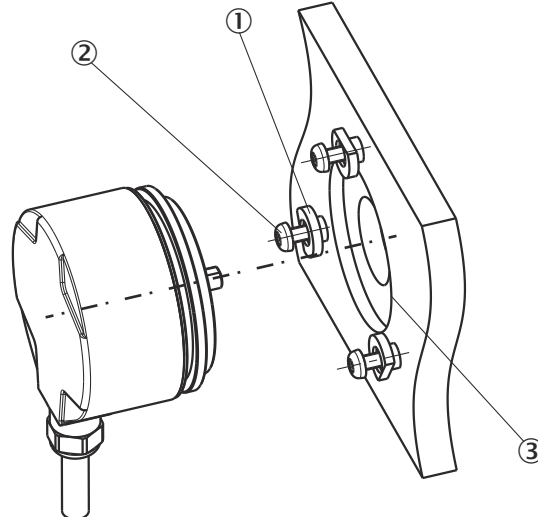

Figure 9: Mounting a servo flange with servo clamps

- ① Servo clamps
- ② Screws
- ③ Centering collar

1. Secure the servo clamps and the screws loosely and apply screw adhesive (observe section [section 5.3](#)) to each thread at the same time.
2. Align the servo clamps so that the encoder can be pushed into the centering collar.
3. Insert the encoder into the centering collar.

4. Insert the servo clamps into the servo groove by rotating them. Ensure maximum overlap and secure by screwing in the screws.
5. Tighten the screws; tightening torque: 1.2 ± 0.1 Nm.
6. Create a shaft connection between the encoder and the drive shaft using a suitable, flexible connection (observe section [section 4.2.2](#)).

5.8 Mounting a solid shaft encoder with a servo flange using servo clamp half-shells

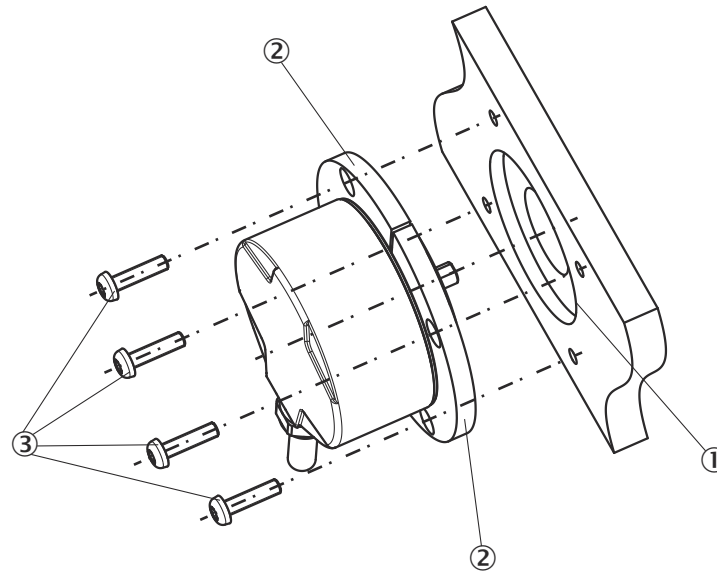

Figure 10: Mounting with servo clamp half-shells

- ① Centering collar
- ② Servo clamps half-shells
- ③ Screws

1. Insert the encoder into the centering collar.
2. Mount the servo clamp half-shells and the screws and apply screw adhesive (observe section [section 5.3](#)) to each thread at the same time.
3. Tighten the screws; tightening torque: 1.2 ± 0.1 Nm.
4. Create a shaft connection between the encoder and the drive shaft using a suitable, flexible connection (observe section [section 4.2.2](#)).

6 Electrical installation



WARNING

Risk of injury from electrical voltage.

- ▶ Make sure the affected machines / systems / vehicles are in a de-energized state before mounting!



NOTICE

- ▶ Observe the corresponding operating instructions of the external drive and monitoring system or the higher-order control system for installation of the safety encoder.

6.1 Shield cover



NOTICE

To ensure fault-free operation of the encoder, the cable shield of the connecting cable must be grounded on both sides (encoder and control) using large area connections. On the encoder side, this is typically done in the male connector or via the connecting cable.

- ▶ Make sure that the encoder on the machine is grounded via the protective conductor of the motor. This is typically done with a clean and electro-conductive connection between the motor and encoder. If this is not the case, ground the encoder with a short low-resistance cable.

6.2 Signals of the safety encoder

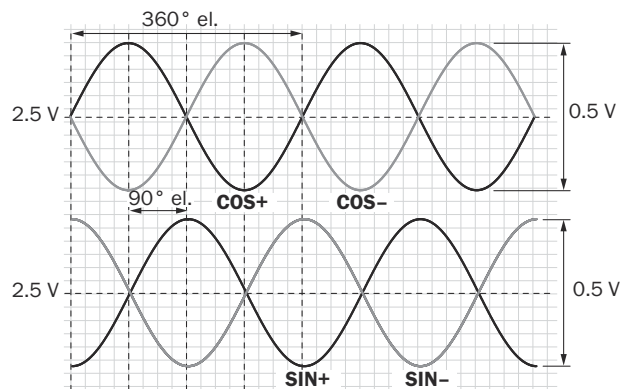

Figure 11: Process data channel 1, signals before difference generation at 120 ohm load. Signal diagram for clockwise (CW) shaft rotation, looking in direction of the shaft

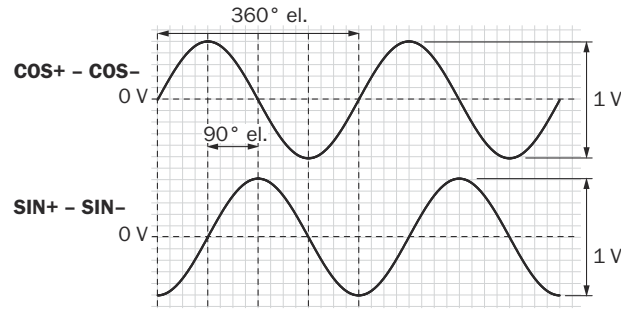

Figure 12: Process data channel 1, signals after difference generation at 120 ohm load. Signal diagram for clockwise (CW) shaft rotation, looking in direction of the shaft

The safety encoder has the following signals:

US	Supply voltage, the supply voltage range measured on the safety encoder is between 4.5 V and 32 V. ¹⁾
GND	Ground connection, electrically isolated from the housing. The voltage relating to GND is US.
SIN+	Process data channel 1, SIN+ is a sine signal of 0.5 V _{pp} with a static offset of 2.5 V.
SIN-	Process data channel 1, SIN- is a sine signal of 0.5 V _{pp} with a static offset of 2.5 V. SIN- is complementary to the SIN+ signal.
COS+	Process data channel 1, COS+ is a cosine signal of 0.5 V _{pp} with a static offset of 2.5 V. The COS+ signal is phase-shifted by 90° in relation to the SIN+ signal.
COS-	Process data channel 1, COS- is a cosine signal of 0.5 V _{pp} with a static offset of 2.5 V. COS- is complementary to the COS+ signal.
CLOCK+	Process data channel 2, CLOCK+ is a digital input signal (clock) for serial data transmission.
CLOCK-	Process data channel 2, CLOCK- is a digital input signal (clock) for serial data transmission. CLOCK- is complementary to the CLOCK+ signal.
DATA+	Process data channel 2, DATA+ is a digital output signal (data) for serial data transmission.
DATA-	Process data channel 2, DATA- is a digital output signal (data) for serial data transmission. DATA- is complementary to the DATA+ signal.
SET	Set (preset) position of the encoder via the hardware pin, see "Configuration of CW/CCW inputs and SET via hardware pin" , page 30.
CW/CCW (V/R)	(Clockwise/Counterclockwise) The counting direction of the safety encoder is set via a hardware pin, see "Configuration of CW/CCW inputs and SET via hardware pin" , page 30.

1) For safety encoders with M12 male connector, this range is between 4.5 V and 30 V.

Permissible length of cable for maximum output frequency of process data channel 1 (SinCos) depending on the supply voltage:

Us	Max. cable length ^{1) 2)}	Max. clock frequency ³⁾
4.5 V ... 5.0 V	5 m	1 MHz
5.0 V ... 7.0 V	10 m	1 MHz
7.0 V ... 10 V	50 m	500 kHz
10 V ... 12 V	100 m	500 kHz
12 V ... 32 V	150 m	400 kHz

1) Data cable 6 x 2 x 0.14 mm² with shield

2) For encoders with cable outlet including cable outlet (total length)

3) Clock frequency of process data channel 2 (SSI)

6.2.1 Singleturn

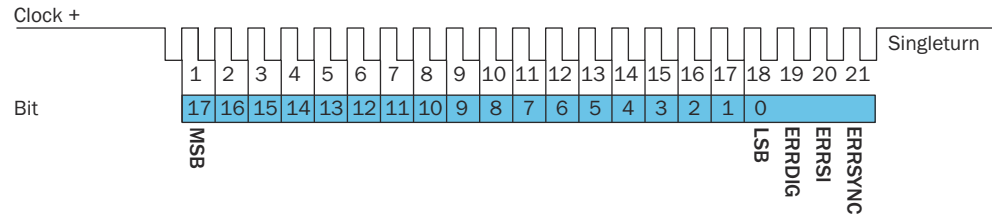

Figure 13: Process data channel 2, SSI data format singleturn, 18 bits

Bit 1-18: Position bits

- LSB: Least significant bit
- MSB: Most significant bit

Bit 1-21 = HIGH: Send "1"

Bit 19-21: Error bits

An internal monitoring system continuously tests the function of the safety encoder. If an encoder detects an error, the error status is displayed to the evaluation system by the SSI channel only outputting "1", whereby the error bits are set.



NOTE

The evaluation of at least one error bit must be realized in the control.

If the safety encoder is set to a resolution of 13 bits, 16 bits, 13 data bits and 3 error bits are output.

6.2.2 Multiturn

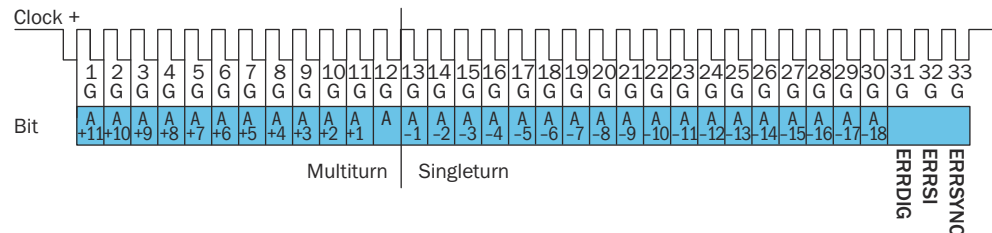

Figure 14: Process data channel 2, SSI data format multiturn, 30 bits

Bit 1-30: Position bits

- Bit 1-12: Multiturn position bits
- Bit 13-30: Singleturn position bits

Bit 1-33 = HIGH: Send "1"

Bit 31-33: Error bits

An internal monitoring system continuously tests the function of the safety encoder. If an encoder detects an error, the error status is displayed to the evaluation system by the SSI channel only outputting "1", whereby the error bits are set.



NOTE

The evaluation of at least one error bit must be realized in the control. 3 error bits are also sent along and should be considered in the control configuration.

The resolution of the multiturn is permanently set to 12 bits.

If the safety encoder is set to a resolution of 25 bits, 28 bits, 12 multiturn data bits, 13 singleturn data bits and 3 error bits are output.

6.3 Connector and connection cable

6.3.1 M23, 12-pin

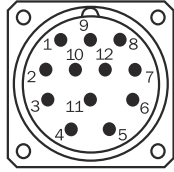

Figure 15: M23, 12-pin

Table 5: PIN assignment M23, 12-pin

PIN	Signal
1	US
2	GND
3	CLOCK+
4	DATA+
5	SET
6	DATA-
7	CLOCK-
8	SIN-
9	CW/CCW (V/R)
10	COS-
11	COS+
12	SIN+
Screen	Encoder side connected to housing

6.3.2 M12, 12-pin

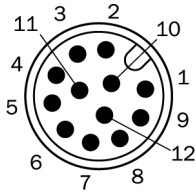

Figure 16: M12, 12-pin

Table 6: PIN assignment M12, 12-pin

PIN	Signal
1	CW/CCW (V/R)
2	DATA+
3	DATA-
4	CLOCK-
5	US
6	COS+
7	COS-
8	SIN+
9	SIN-
10	SET

PIN	Signal
11	CLOCK+
12	GND
Screen	Encoder side connected to housing

6.3.3 Cable connection, 12-wire



NOTE

Observe the smallest permitted bend radius of the connecting cables (permitted bend radius for encoder with cable outlet: min. $10 \times$ outer diameter of the cable).

Connection with open cable ends. Wire cross-section: $6 \times 2 \times 0.15 \text{ mm}^2$ with shielding.

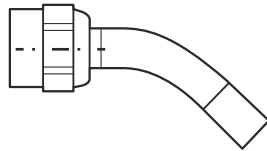

Figure 17: Cable connection, 12-wire

Table 7: Cable connection cable assignment, 12-wire

Wire color	Signal
Red	US
Blue	GND
Pink	SIN+
Black	SIN-
Gray	COS+
Green	COS-
Yellow	CLOCK+
Violet	CLOCK-
White	DATA+
Brown	DATA-
Orange	SET
Orange / Black	CW/CCW (V/R)
Screen	Encoder side connected to housing

6.4 Delivery state

The safety encoder does not contain a standard configuration in the delivery state:

- Maximum singleturn resolution
- CW counting direction (with view to the shaft)
- Preset value = 0 preset

7 Configuration of CW/CCW inputs and SET via hardware pin

This chapter describes the two inputs with which the counting direction and the current position value can be configured for the programmable encoders.



NOTE

All possible settings and configurations effect only channel 2 of the safety encoder and therefore the position information output via SSI. This must be considered in particular during setting and evaluation of the counting direction.

7.1 Counting direction CW/CCW



NOTICE

The HIGH/LOW assignment of the CW/CCW input must only be changed when switched off.

This input programs the counting direction for the encoder. When it is not connected, this input is set to HIGH. If the encoder shaft is rotated clockwise (to the right) as viewed when facing the shaft, it counts in ascending order. If it should count in ascending order when the shaft is rotated counterclockwise (to the left), then this connection must be permanently set to LOW level (GND).

Position counting direction:

- LOW level = Downwards / CW
- HIGH level = Upwards / CW

Negative counting direction:

- LOW level = Upwards / CW
- HIGH level = Downwards / CW

The CW/CCW input is evaluated during initialization. The level must be held constant for unique evaluation. Faults and signal failures can lead to errors and limits on availability.

The signal is only detected in the initialization phase, a LOW or HIGH level must be applied for at least 1,000 ms .

Level changes during operation are not evaluated.

7.2 Setting position value via SET



NOTICE

Setting the preset value using the SET input may only be done during shaft downtime.

This input is for an electronic preset. If the SET cable is connected to US for more than 250 ms after it had previously been unassigned for at least 1,000 ms or connected to GND, the mechanical position corresponds to the value 0 or the specified SET value, see "[Configuration](#)", page 38.

If the applied signal does not correspond with the defined signal path or if the shaft is not in a downtime state, the preset value cannot be set and the availability may be limited.

If there is a false signal, a set is not triggered. The availability is not limited. The error state is not triggered until there is a valid signal and remains for the entire duration of the SET process. If the shaft moves at the time of the SET process, the position is NOT changed.

- ▶ A check must first be done to determine if the setting of the desired position was successful.
Read out the SSI position and compare with the expectation.

In order to compare the absolute position of the two channels of the safety encoder, it may be necessary for the standard value for the counted position, based on channel 1 (Sin/Cos signals) to also be initialized with the expected value.

8 Configuration with Safety Designer

This chapter describes the configuration of the safety encoder using Safety Designer. The configurable variants of the safety encoder (see "Product identification", page 10) can be configured with the Safety Designer in version 1.8 or newer. Another tool must not be used. More information regarding Safety Designer can be found in the operating instructions for the Safety Designer item no. 8018179.

This chapter also describes transmitting configuration data from and to the device, creating reports and the service options offered by Safety Designer.

8.1 Encoder connection / Configuration tools

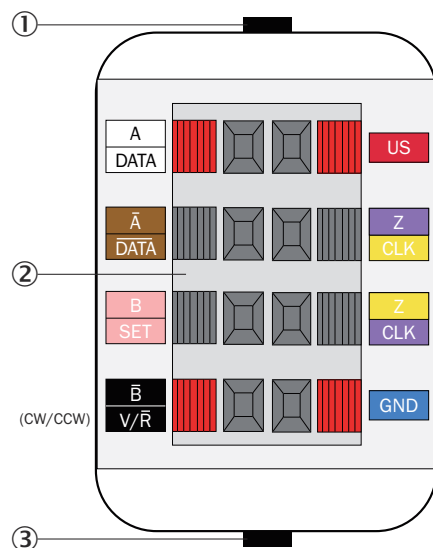

Figure 18: Connection diagram PGT-08

- ① Cable with USB connection for connecting to PC/laptop
- ② Spring terminal block (for encoders with a cable outlet)
- ③ Cable with SUB-D connection (9-pin) for connecting to encoder-specific programming cables (for encoders with a connector outlet)

Connecting PGT-08-S hardware and encoder / connection to PC



NOTICE

Risk of damage due to incorrect adapter cable.

The programming tool must only be used with the designated adapter (see "Accessories", page 64).

Other adapter cables are not permitted. Otherwise, this could result in damage to the programming tool and/or the encoder.

The following connection steps must be observed:



NOTICE

- ▶ Only connect a single encoder to the PGT.
- ▶ Only connect a single PGT to the PC.



Figure 19: M12 connecting cable PGT-08-S



Figure 20: M23 connection cable PGT-08-S

1. Connect the encoder with the associated cable. Encoders with cable outlet and open cable ends can be connected to the spring terminal boxes in accordance with figure 21 .

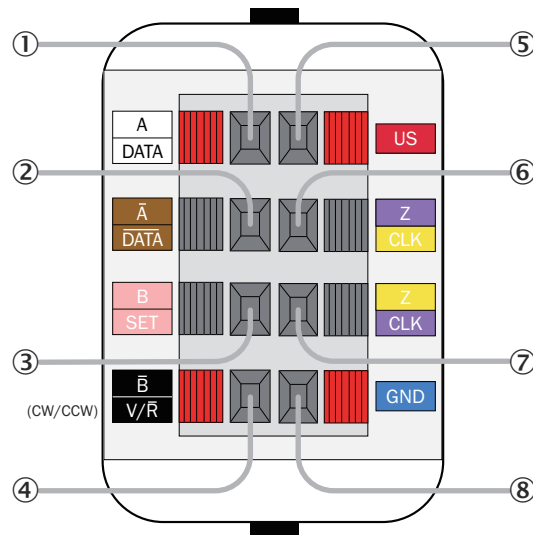

Figure 21: PGT-08-S connection diagram

- ① White
- ② Brown
- ③ Pink
- ④ Black
- ⑤ Red
- ⑥ Yellow
- ⑦ Violet
- ⑧ Blue

2. Connect the cable to the PGT-08-S hardware in accordance with the connection diagram.
3. Connect the PGT-08-S hardware to your PC using a USB port.



NOTICE

The USB interface of the PGT-08-S hardware is designed solely for direct connection to a computer. USB hubs or extensions should not be used.

8.2 Installation assistant

An installation assistant will help you to install Safety Designer.

1. Go to the download page. To do this, www.sick.com enter **Safety Designer** in the search field.
2. Take note of the system requirements on the download page.
3. Download the installation file from the download page. Extract it and run it.
4. Follow the notes from the setup assistant.

8.3 Start

Overview

Following startup, Safety Designer displays the Home screen.

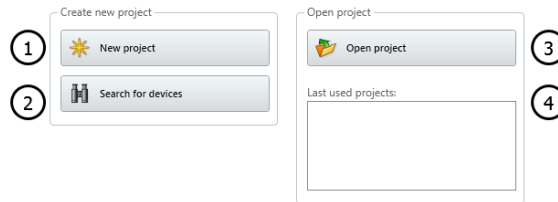

Figure 22: Home screen

- ① Create and open a new project.
- ② Search for connected devices.
- ③ Open an existing project.
- ④ Open a recently saved project.

Important notes

Certain functions (for example verification) can only be performed on a PC that meets all the system requirements.

When starting up, the Safety Designer checks the hardware and the operating system. The Safety Designer reports any issues that were found.

Procedure

- ▶ Select one of the options.
- ✓ Safety Designer switches to its user interface.

8.4 Projects

Using Safety Designer, you can configure one or more devices in a project. You can save the configuration data in a project file on the PC.

Creating a project

- ▶ Click on **New project**.
 - ✓ This creates and opens an empty project.

Configuring a device online (device connected to PC)

The following interfaces are suitable for configuration:

- USB-A
The USB connection may only be used temporarily and only for configuration and diagnostics.

If a device is connected to the PC, Safety Designer can establish a connection to the device.

You will then configure the device online. In this case, you can transmit the configuration to the devices directly and use diagnostic functions.

- ▶ Click on **Connect**.
 - ✓ Safety Designer searches for connected devices, with which it can establish a connection.

Configuring a device offline (device not connected to PC)

- ▶ If the device is not connected to the PC, select it from the device catalog. You can also enter the type code directly in the device catalog. You will then configure the device offline. Diagnostics functions are not available. You can connect the PC to the device later and transmit the configuration.

8.5 User interface

This chapter gives information about how to use the software's controls.

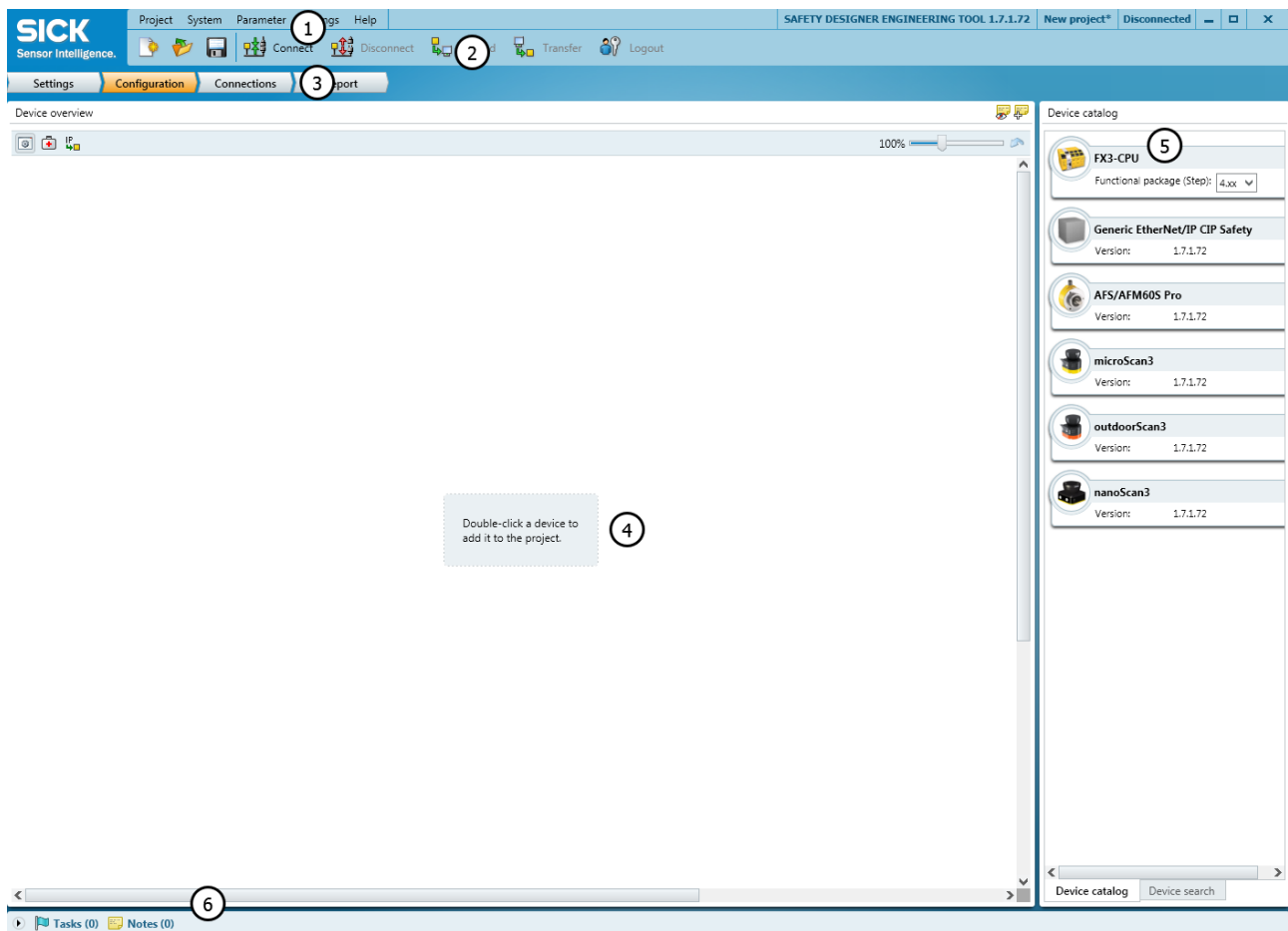

- ① Menu bar
- ② Toolbar
- ③ Navigation
- ④ Workspace
- ⑤ Device catalog
- ⑥ Task list and notes

8.5.1 Menu and toolbar

Menu bar

The following menus are available in the menu bar:









- **Project**
 - Create a new project
 - Open
 - Open last projects used
 - Save
 - Save as
 - Close project
 - End Safety Designer
- **System**
 - Connect to a project
 - Terminate the connection to a project
- **Parameter**
 - Read from device
 - Transfer to device
- **Settings**

- Select language.
- Call up options
- **Help**
 - Call up help (operating instructions)
 - Call up information on software version
 - Update device catalog
 - License information

Toolbar

The toolbar includes the commands needed for the various work situations. All the buttons on the toolbar are described below. Depending on the jobs in progress, fewer buttons may be displayed (e.g., immediately following startup of Safety Designer).

Table 8: Buttons on the toolbar

Button	Meaning
	Create new project
	Open project
	Save project as file
	Connect to a device or system configuration
	Disconnect from a device or system configuration
	Read configuration from the device or system configuration
	Transfer configuration to a device or system configuration
	Logout from all devices

8.6 User groups

The devices contain a hierarchy of user groups that regulate access to the devices. The user groups' settings and passwords are part of the configuration stored in the device.

For certain actions (e.g., transferring a configuration to the device), you are requested to log onto the device with the respective user group.



NOTICE

If you leave a computer unattended, which is connected to devices, you must log out of the **maintenance technician** or **authorized client** user groups and change to the **machine operator** user group, so that unauthorized people cannot transmit configurations to the devices.

User group	Password	Authorization
Machine operator	Does not need a password (anyone can log in as a machine operator).	May import configuration from the device (as long as they are not blocked).

User group	Password	Authorization
Maintenance	Does not have a factory-set password. The password is created by the authorized client (namely, it is not possible initially to log in as a maintenance technician).	May import configuration from the device. May transmit verified configuration to the device.
Authorized client	The password SICKSAFE is created at the factory. Change this password to protect the device against unauthorized access.	May import configuration from the device. May transmit verified and unverified configuration to the device. May verify configuration. Can set a password for maintenance technicians.

8.6.1 Changing user group

1. Establish a connection to the device.
2. In the toolbar, click on the **User** button.
- ✓ The **Log in** dialog box is opened.
3. Select the desired user group.
4. Enter the password and click on **Log in**.

8.7 Operation



NOTE

The password SICKSAFE is created for the authorized client user group.

8.7.1 Settings

Entering project information

The project information contains details that are used, for example, in the project area. The user name helps subsequent users to find a contact for the project. A description makes it easier to understand a project's context more quickly.

Procedure

- ▶ Under **Project Information**, you can enter a user name, a project name, and a short description of the project.
- ✓ The project information is saved in the project.

The network, connection via network router, time synchronization and data recorder navigation points are not supported by the encoder.

Time synchronization

You can synchronize the time and date of the devices in the network. This is important, amongst other things, for ensuring that diagnostics and reports have synchronized and correct time stamps.

8.7.2 Configuration

In the **Configuration**, area you can compile the devices for a project. The available devices can be found in the Device Catalog. The devices are displayed as Device tiles in the working area.

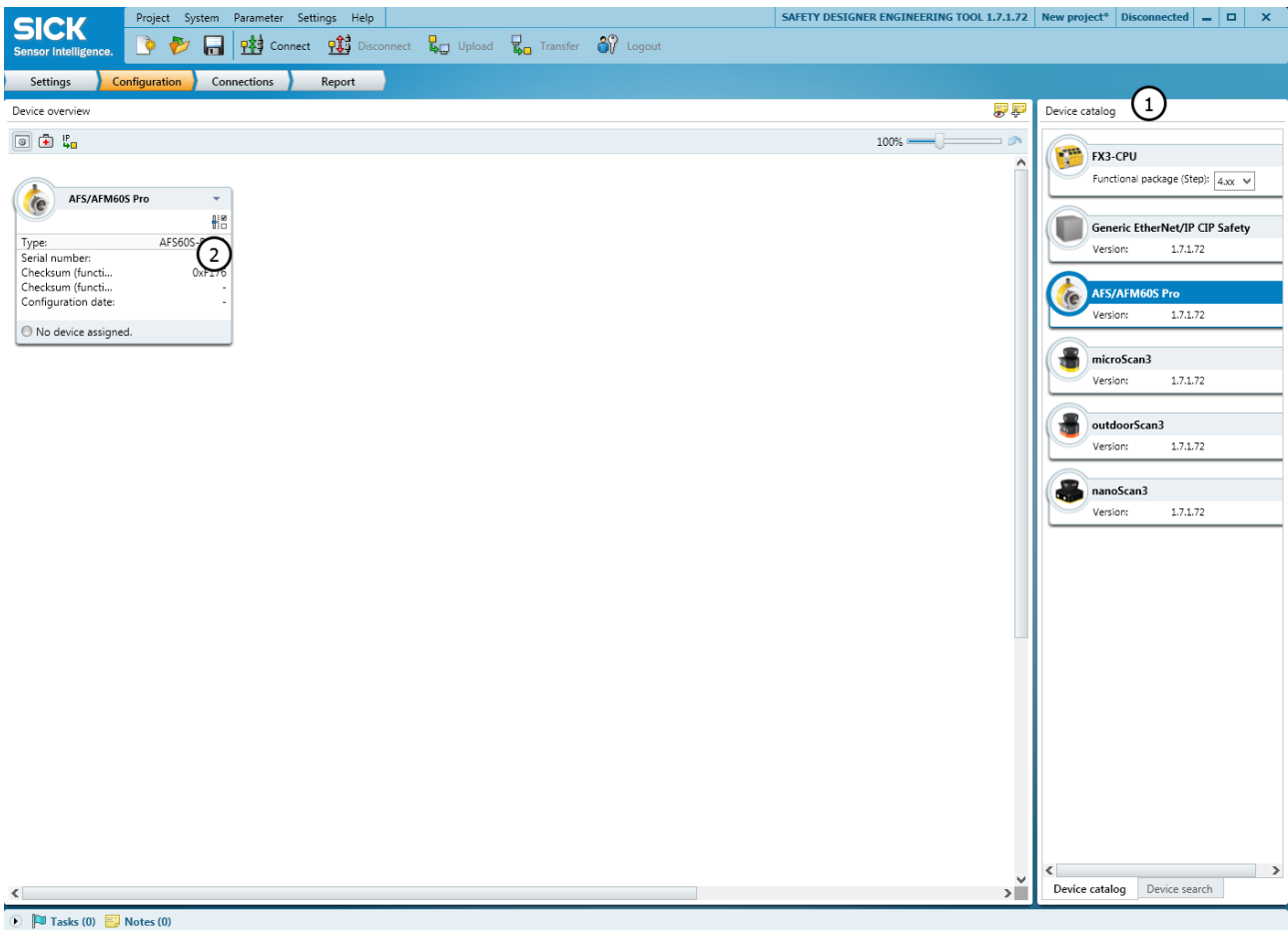

Figure 23: Configuration



- ① Device catalog
- ② Device tile

8.7.2.1 Device catalog

The device catalog contains all available devices.

- The **Device catalog** tab contains the devices installed in Safety Designer.
- The **Device search** tab contains the devices found during a device search.

Table 9: Buttons in the device catalog

Button	Meaning
	Search for devices one time
	Remove devices which are no longer detected from the list of found devices.
	Settings for the device search

The devices from the device catalog can be compiled in a project in the working area.

- ▶ Drag a device into the working area using drag and drop.
Or:
- ▶ Double-click on a device in the device catalog.
When a device is configured offline for the first time, the device selection assistant opens. This is where you select the type of device to be configured.
- ✓ The device is shown as a tile in the working area.

8.7.2.2 Opening the device window – configuring devices

Open a device window to configure a device, perform diagnostics, or create reports. You have the following options:

- ▶ Click on the Device tile.
Or
- ▶ Open the tile menu and choose **Configure**.
✓ The device window opens.
When a device is configured offline for the first time, the device selection assistant opens. This is where you select the type of device to be configured.

8.7.2.3 Importing the configuration

Safety Designer can import the configuration from connected devices.

- ▶ In the **Parameter** menu, select the **Read from device** command or click on **Read from device** in the toolbar.
- ✓ The **Import devices** dialog box is opened. The connected devices are displayed in this dialog box.
- ▶ Click on **Import devices**.
- ✓ Safety Designer imports the configuration from connected devices.

8.7.2.4 Overview

The **Overview** menu contains information about the safety encoder.

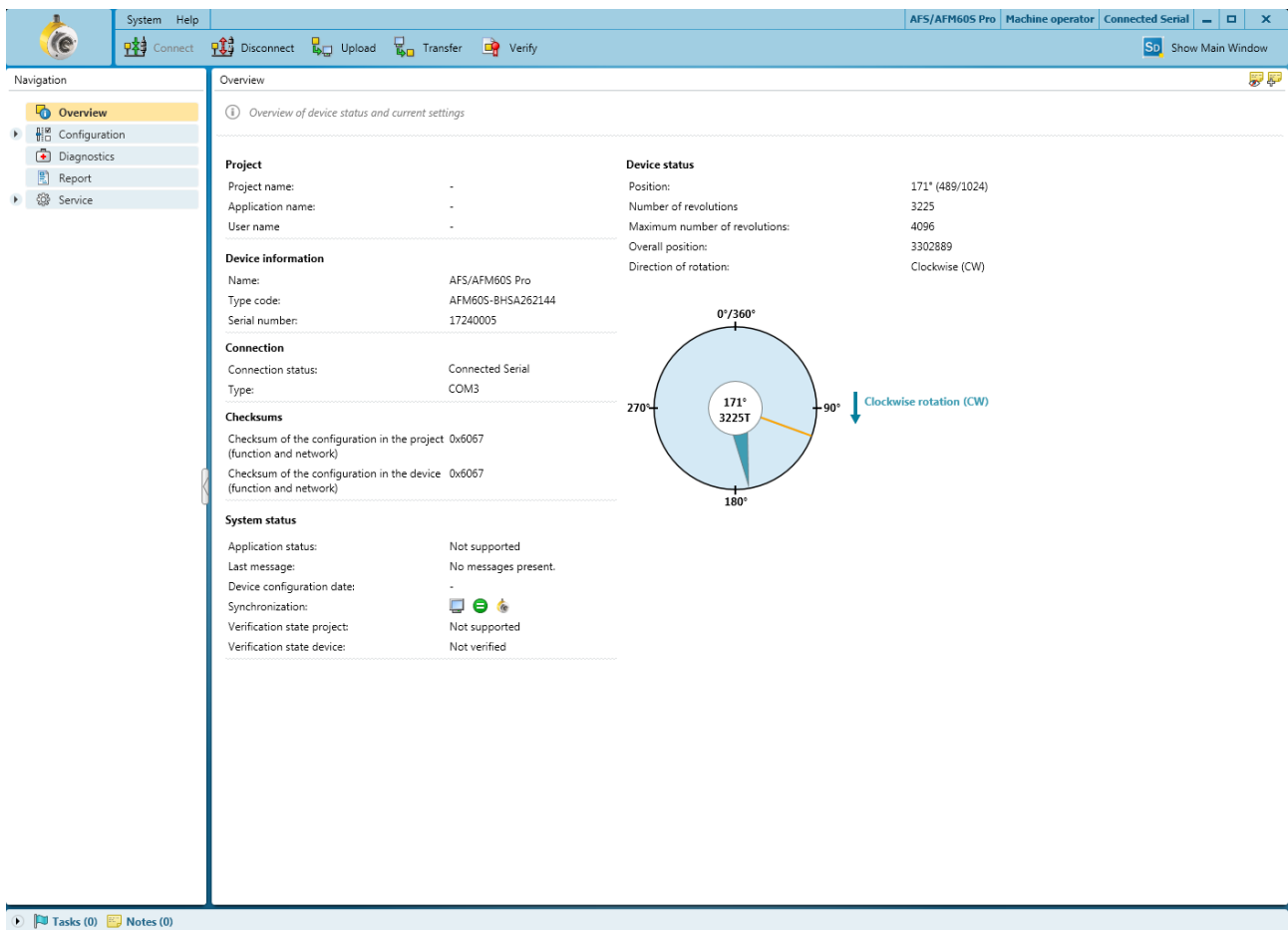

Figure 24: Overview

Project

- Project name: This name should be chosen for all devices in the project
- Application name: This name can be the same for a number of devices in the project. It highlights that these devices realize an application together, by responding to one another for example.
- User name: The name of the user

Device information

- Name: Used to identify the individual device
- Type code of the safety encoder
- Serial number of the safety encoder

Connection

- Connection status
- Type of connection

Checksums

- Checksum of the configuration in the project
- Checksum of the configuration in the device

System status

- Application status: Not supported
- Current message of the safety encoder
- Configuration date for the configuration in the device
- Synchronization: Shows whether the configuration in Safety Designer and the configuration in the device are identical

- Project verification status: Not supported
- Device verification status: Shows whether the configuration is verified

Device state

Shows the measurement data for the connected device (the configuration must be read out of the device)

- Position: Turning position of the shaft in degrees and in resolution steps (current resolution step / overall resolution step)
- Number of revolutions (multiturn)
- Maximum number of revolutions (multiturn)
- Total position: Sum of all previous steps within the maximum revolutions
- Counting direction: CW, CCW (CW clockwise, CCW counter clockwise)

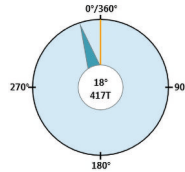

Figure 25: Encoder visualization

- T = Turns: Number of revolutions
- Blue pointer = Steps per revolution
- Orange pointer = Read out (valid) preset position
- Gray pointer = New preset position. This pointer is displayed in orange after transmission to the device.

Establishing connection

1. Check whether the safety encoder is connected correctly.
 2. Click on **Connect**.
- ✓ Safety Designer creates the connection to the safety encoder.

8.7.2.5 Configuration

In the Identification dialog box, you can assign names and information to uniquely identify the application, project and devices.



NOTICE

All possible settings and configurations effect only channel 2 of the safety encoder and therefore the position information output via SSI. This must be considered in particular during setting and evaluation of the counting direction.

8.7.2.6 Parameterization

In the **Parameterization** menu, the values of the safety encoder must be adjusted to the application conditions.

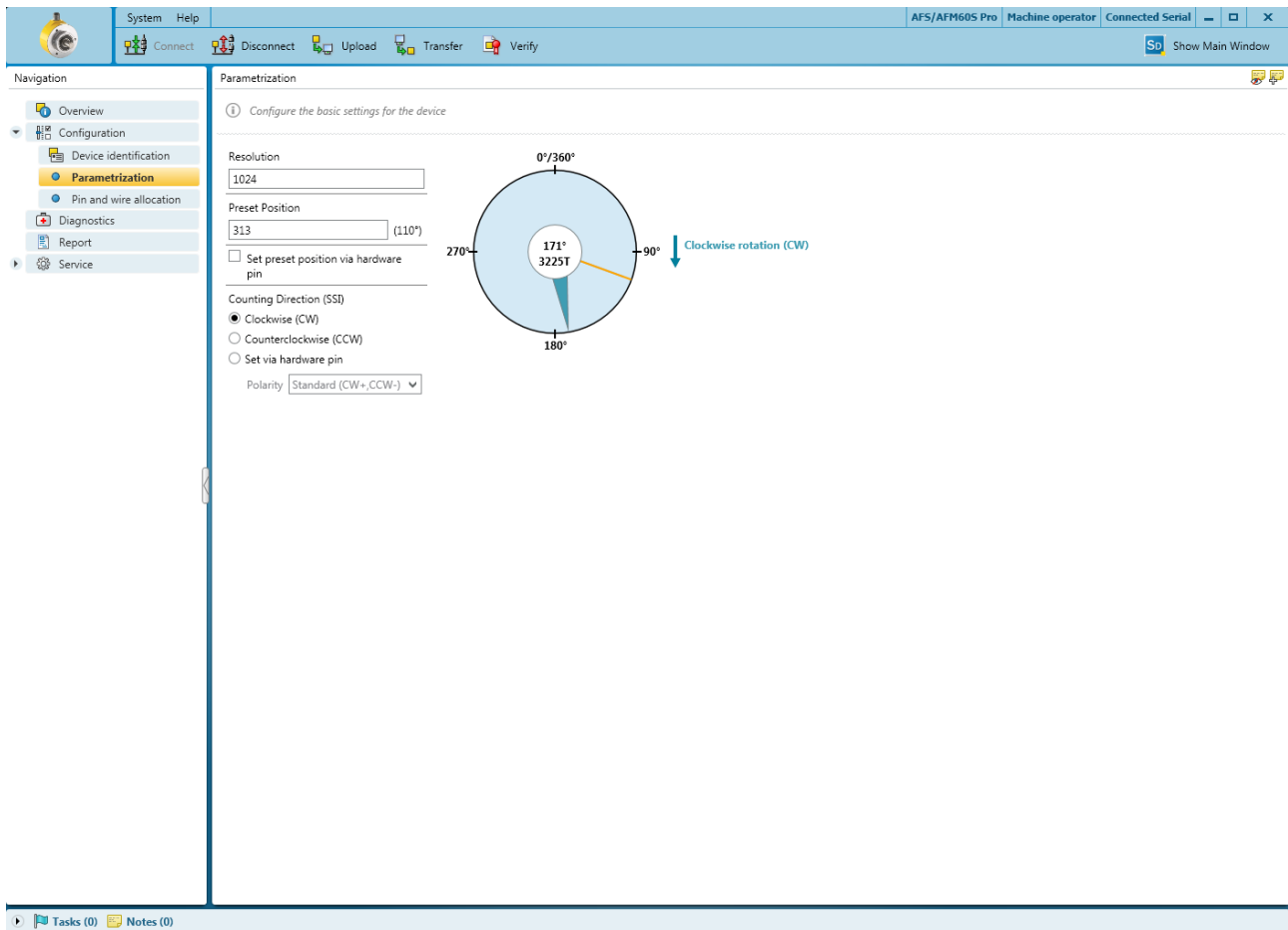

Figure 26: Parameterization

- Resolution: Steps per revolution (singleturn resolution):
 - Singleturn encoder: 4 ... 262,144
 - Multiturn encoder: 4 ... 262,144 in binary steps ($2^2 \dots 2^{18}$)
 The number of revolutions (multiturn resolution) is fixed to 4,096 revolutions.
- Preset position: Start point of the encoder in resolution steps. A new preset position is visualized by a gray pointer (after transmission into the device, the graphics are updated and replaced by an orange pointer).
 - The preset position can be transferred by transmitting the configuration into the device or by setting the preset position (see "Service", page 46).
 - Setting preset position via hardware pin: The physical position of the encoder is overwritten by the preset position. The preset position "0" is saved at the factory and for offline project planning. The preset position is set by wiring the hardware pin (see "Configuration of CW/CCW inputs and SET via hardware pin", page 30).
- Counting direction (SSI)
 - Clockwise (CW)
 - Counter clockwise (CCW)
 - Define via hardware pin
 - Polarity standard, not connected (CW+, CCW-)
 - Polarity inverted, not connected (CW-, CCW+)

8.7.2.7 PIN and wire allocation

The **Pin and wire allocation** menu contains information on the pin and wire allocation of the safety encoder and the programming interface (PGT-08-S).

8.7.2.8 Diagnostics

The **Diagnostics** menu logs device messages of all kinds:

The screenshot shows the Safety Designer software interface. The top menu bar includes 'System' and 'Help'. The main window is titled 'Messages' and contains a table of error messages. The table has four columns: 'Type', 'Error code', 'Message', and 'Acknowledged'. The messages are all of type 'Error' and relate to a safety encoder signaling an application error. The Acknowledged column shows green checkmarks. Below the table, a detailed view of an error message is shown, including the code (0xA2200010), local time occurrence, reason, solution, and additional information.

Type	Error code	Message	Acknowledged
Error	A2200010	The safety encoder signaled an application error (0xa2200010)	✓
Error	A2100020	The safety encoder signaled an application error (0xa2100020)	✓
Error	A2000010	The safety encoder signaled an application error (0xa2000010)	✓

Code	0xA2200010
Local time occurrence	1617/0 days 0 h 0 min 0 s 000 ms
Reason	The safety encoder signaled an application error and thus activated its error status in SSI mode.
Solution:	Is the device is within the specifications, it is being rebooted. After the initialization, the encoder is ready for operation and can support the safety function.
Additional information 0	4150
Additional information 1	0
Additional information 2	0
Additional information 3	0

Figure 27: Diagnostics

- Warning
- Error
- About
- Event

In addition to the message, a counter is outputted. This specifies how often the device was restarted and therefore enables the time of the fault to be localized. The error code makes it possible to clearly identify the error situation.

Messages can be acknowledged as seen by clicking on the green check mark.



NOTE

Device messages also contain additional information for users. There is a difference between application errors and safety-critical errors. If the error status is permanently activated and cannot be remedied by a restart (power cycle), there is a device error.

- In this case, replace the safety encoder and contact your responsible SICK subsidiary.

8.7.2.9 Report

Using reports, you can compile information about all the devices in a project, save it as a PDF and archive it.

You can create reports on individual devices in the relevant device window.

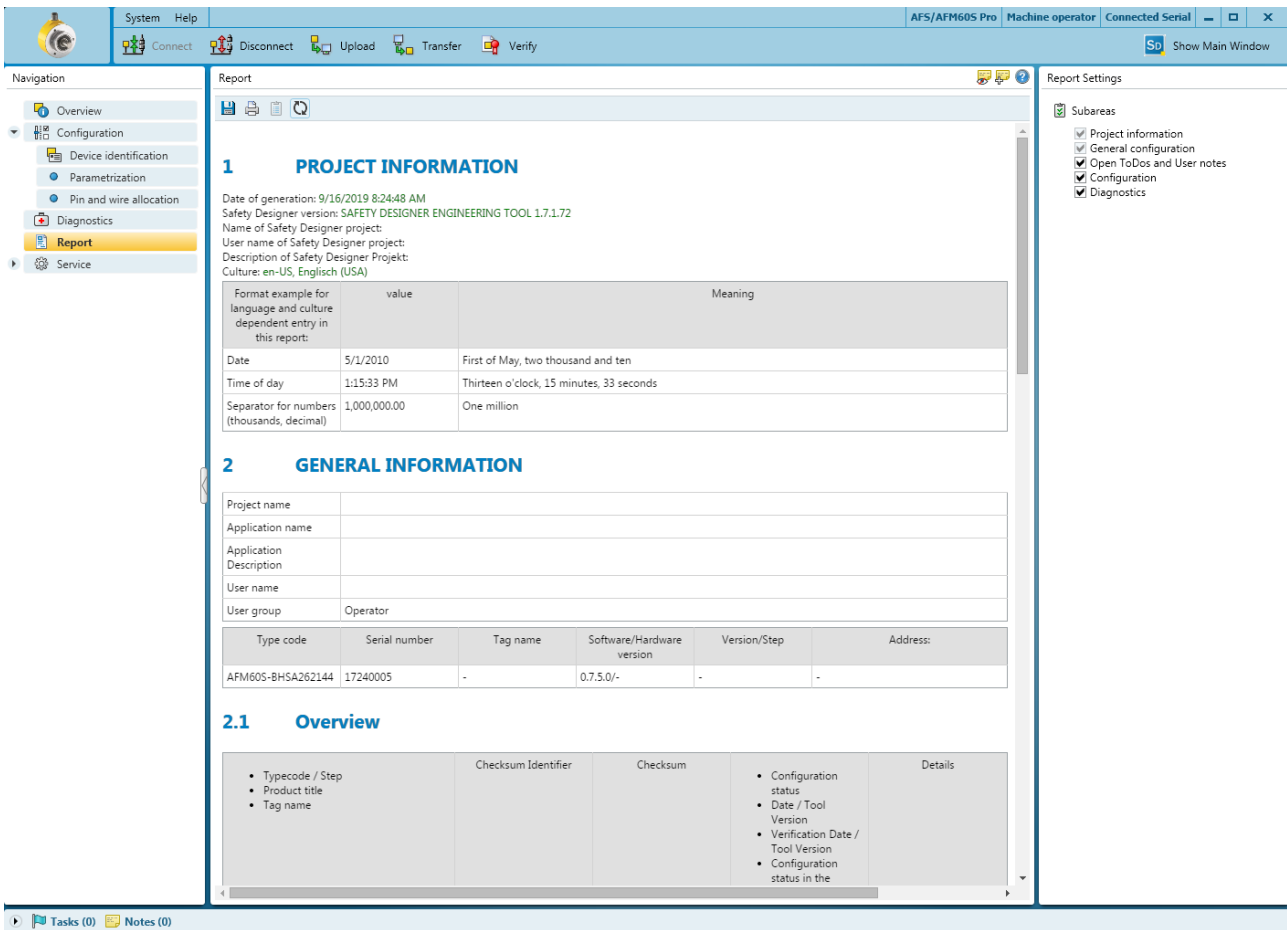





Figure 28: Example of a report

- ① Contents of the report
- ② Buttons on the report
- ③ Sorting
- ④ Compilation of the contents

Buttons on the report

Table 10: Buttons on the report

Button	Meaning
	Save report as a PDF
	Print report
	Save project components
	Refresh report

Sorting

- ▶ Select Sort devices.
- ✓ The contents will be compiled by individual device.

- ▶ Select Sort **chapters**.
- ✓ The contents will be compiled in chapters according to theme, e.g., configuration, parts list etc.

User-specific compilation of contents

- ▶ Mark the desired **devices** or **working areas** of the report in the list.
- ✓ All selected information is displayed.

8.7.2.10 Service

This section describes the service options which you have on the safety encoder with Safety Designer.

Reset the device

The configuration for the safety encoder is reset to factory settings.

Preset position

The encoder is set to the set preset position.

Password management

Assigning or changing passwords



NOTE

The password must be between 1 and 8 characters long.

1. Establish a connection to the device.
2. In the device window, under Service, choose the entry **User password**.
3. Choose the user group in the User password window.
4. Enter the new password twice and use **Accept** to confirm.
5. If you are requested to log in, log in as an Authorized customer.
- ✓ The new password is valid for the user group immediately.

Reset password

If you have forgotten a password, you can reset it.

1. Request the form for resetting your password from SICK support.
2. Connect to the device in Safety Designer.
3. In the device window, under Service, choose the entry **User password**.
4. Choose the option **Reset password** in the User password window.
5. Transmit the serial number shown and the device counter together with the product number and the type code on the form to SICK support.
- ✓ You will then receive a reset code.
6. Enter the reset code under **Password reset** and use **Accept** to confirm.
- ✓ The passwords are reset to factory settings (SICKSAFE for an authorized client, no password for machine operators. It is not possible for maintenance technicians to log in). The configuration is not changed.

8.7.2.11 Transfer configuration

You can transfer a new or altered configuration to connected devices.

At first, a configuration only exists as a project, i.e., as a configuration file; it needs to be transferred to the device. The compatibility of the configuration is checked during the transfer.

- ▶ In the **Parameter** menu, select the **Transfer to device** command or click on **Transfer to device** in the toolbar.

- ✓ The **Transfer devices** dialog box is opened. The connected devices are displayed in this dialog box.
- ▶ Click on **Transfer devices**.
- ✓ The **Log in** dialog box is opened.
- ▶ Select the user group **Authorized customer** and enter the **password**.
- ▶ Click on **Log in**.
- ✓ The progress of the transfer process is displayed in Safety Designer.



Figure 29: Progress display

8.7.2.12 Verify configuration

The configuration must be verified to ensure that the partial safety function is implemented correctly.

- ▶ Select **Verify** in the Tile menu.
- ✓ Safety Designer displays the configuration report.
- ▶ Check the configuration report, and, if appropriate, click on **Confirm**.
- ✓ The device configuration is shown as verified.



Figure 30: Symbol for “device configuration verified”



NOTE

Without a verified configuration, no valid position is output to channel 2 (SSI).

8.7.2.13 Disconnect

Disconnect the Safety Designer from all devices:

1. In the **System** menu, select the **Disconnect** command or click on **Disconnect** in the toolbar.
- ✓ The status of the Safety Designer and the status of the Device tiles will change to **Disconnected**.
- ✓ The device symbols in the **Device search** tab are deleted.

Disconnect the Safety Designer from one single device:

1. Select the **Disconnect** command in the Tile menu for the respective Device tile.
- ✓ The status of the Device tile will change to **Disconnected**.



NOTE

Once the last connected Device tile has been disconnected, the status of the Safety Designer will then also change to **Disconnected**.

9 Commissioning



NOTICE

Do not commission without a thorough check by qualified safety personnel.

Before you commission a system or a machine into which the safety encoder is integrated for the first time, the machine or system must be checked and approved by qualified safety personnel. Observe the notes provided in the safety chapter (see ["Safety information", page 8](#)).

9.1 Inspection instructions

- ▶ Ensure that an AFS/AFM60S Pro safety encoder and not an AFS/AFM60E, AFS/AFM60B or AFS/AFM60A standard absolute encoder is being used during commissioning.
- ▶ Observe the initialization time after switching on. The safety encoder does not output any valid signals during this time.
- ▶ Determine the reference position value during commissioning (e.g. reference run) which serves as the initial value for the counting (Sin/Cos) channel.



NOTICE

The initial value of the counting (Sin/Cos) channel of the evaluation system must be not taken from the SSI channel.

- ▶ If the position offset of the safety encoder is changed using the SET input, it is then necessary to verify that the sensor is providing the required position value.
- ▶ If the counting direction of the safety encoder is changed using the CW/CCW input, it is then necessary to verify that the sensor is providing the required position value and the desired counting direction. When changing the configuration using Safety Designer, it must be verified whether all partial safety functions work as planned for all relevant speeds and positions.
- ▶ Check whether the maximum temperature that arises at the operating temperature measuring point of the encoder during operation (see ["Technical data", page 52](#)) is within the operating temperature range specified in the technical data.
- ▶ If the temperature at the operating temperature measuring point is above 50°:



NOTICE



Pictogram  Attach the "Warning! Hot surfaces" sign in accordance with IEC 60417-5041 in a visible location on the encoder housing.

- Explain the meaning of the pictogram in the operating instructions of the machine into which the encoder is being integrated.

It may be necessary to determine the reference position value during operation in the event of an error (see ["Project planning", page 14](#)).

Further inspection measures are not required during operation.

10 Maintenance

The safety encoder is maintenance-free. Repairs cannot be carried out in the event of a defect. Please contact us if you have any complaints.

In the event of an error, the error memory of the safety encoder can be read (see "Diagnostics", page 44) to provide information on the cause of the failure.



NOTICE

The safety encoder has a maximum mission time (see "Technical data", page 52) after which it must always be taken out of service. The bearing service life must be taken into account in addition to the mission time T_M . The parameter which is first reached depending on the application determines the time when the system must be taken out of operation.



NOTE

When exchanging the device, observe in particular [section 5](#), [section 6](#) and [section 9](#).

The safety encoder's year of manufacture can be found in the serial number (SN) on the device label or on the packaging label (YYWW).

YY = represents the year (without century)

WW = represents the calendar week of the last manufacturing process.

11 Troubleshooting

11.1 Diagnostics using Safety Designer

Safety Designer can be used to read the error memory of the AFS/AFM60S Pro safety encoder.

The diagnostics monitor whether the encoder is functioning properly as well as environmentally-specific parameters such as temperature and voltage supply. [see "Diagnostics", page 44.](#)

12 Decommissioning

12.1 Disposal

Always dispose of unusable or irreparable devices in accordance with the applicable waste disposal regulations specific to your country.

**NOTE**

We will be glad to help you dispose of these devices. Please contact us.

13 Technical data

Table 11: Technical data - performance

	Singleturn	Multiturn
Number of steps per revolution (max. resolution)	262,144 (18 bit) ¹	-
Max. resolution (number of steps per revolution x number of revolutions)	-	18 bit x 12 bit (262,144 x 4,096)
Error limits G	0.05° ²	
Repeatability standard deviation σ_r	0.002° ³	

¹ Number of steps per revolution is configurable: singleturn encoder 4 ... 262,144; multiturn encoder 4 ... 262,144 binary (2² ... 2¹⁸).

² In accordance with DIN ISO 1319-1, position of the upper and lower error limit depends on the installation situation, specified value refers to a symmetrical position, i.e. deviation in upper and lower direction is the same.

³ In accordance with DIN ISO 55350-13; 68.3% of the measured values are inside the specified area.

Table 12: Technical data - interfaces

Communication interface detailed	SSI + Sin/Cos
Configuration data	Number of steps per revolution, preset position, preset position via hardware pin; counting direction, counting direction via hardware pin, reset factory setting, read error memory, generate report
Initialization time	2 s ¹⁾
Position forming time	< 1 μ s
SSI	
Code type	Gray
Code sequence can be configured	CW/CCW is configurable ²⁾
Clock frequency	100 kHz ... \leq 1 Mhz
Set (electronic adjustment)	H active (L = 0 - 3 V, H = 4.0 - U _s V)
CW/CCW (counting sequence when turning)	L active (L = 0 - 1.5 V, H = 2.0 - U _s V)
Sin/Cos	
Sine/cosine periods per revolution	1,024
Output frequency	\leq 153.6 kHz
Load resistance	\geq 120 Ω
Interface signals before differential generation	0.5 V _{SS} , \pm 20%
Signal offset before differential generation	2.5 V \pm 10%
Interface signals after differential generation	1 V _{SS} , \pm 20%

¹⁾ After this period valid signals can be read.

²⁾ Factory setting: CW when looking at the shaft.

Table 13: Technical data - electrical data

	Solid shaft servo flange	Solid shaft face mount flange	Blind hollow shaft	Through hollow shaft
Connection type	Male connector, M23, 12-pin, radial Male connector, M23, 12-pin, axial Male connector, M12, 12-pin, radial Male connector, M12, 12-pin, axial Cable, 12-wire, radial, 0.5 m Cable, 12-wire, radial, 1.5 m Cable, 12-wire, radial, 3 m Cable, 12-wire, radial, 5 m Cable, 12-wire, radial, 10 m Cable, 12-wire, axial, 0.5 m Cable, 12-wire, axial, 1.5 m Cable, 12-wire, axial, 3 m Cable, 12-wire, axial, 5 m Cable, 12-wire, axial, 10 m		Male connector, M23, 12-pin, radial Male connector, M12, 12-pin, radial Cable, 12-wire, radial, 0.5 m Cable, 12-wire, radial, 1.5 m Cable, 12-wire, radial, 3 m Cable, 12-wire, radial, 5 m Cable, 12-wire, radial, 10 m	
Supply voltage				
Male connector, M23, 12-pin	4.5 ... 32 V			
Male connector, M12, 12-pin	4.5 ... 30 V			
Cable, 12-wire	4.5 ... 32 V			
Power consumption	0.7 W (without load)			
Reverse polarity protection	Yes			
Short-circuit resistance	yes ¹⁾			

1) SinCos interface: Short-circuit to another channel or GND permitted for max. 30 sec. In the case of $U_s \leq 12$ V additional short-circuit to U_s permitted for max. 30 s.

SSI interface: Short-circuit to another channel or GND permitted for max. 30 s. In the case of $U_s \leq 5$ V additional short-circuit to U_s permitted for max. 30 s.

Table 14: Technical data - mechanical data

	Solid shaft servo flange	Solid shaft face mount flange	Blind hollow shaft	Through hollow shaft
Shaft diameter	6 mm	10 mm	6 mm 8 mm 3/8" 10 mm 12 mm 1/2" 14 mm 15 mm 5/8" ¹⁾	
Shaft Length	10 mm	19 mm	-	
Weight	0.3 kg ²⁾		0.25 kg ²⁾	
Shaft material	Stainless steel			
Flange material				
Singleturn	Aluminum		Die-cast zinc	
Multiturn	Aluminum			
Material, stator coupling	Stainless steel			
Housing material	Aluminum die cast			
Start up torque	≤ 0.5 Ncm, at 20 °C		≤ 0.8 Ncm, at 20 °C	
Operating torque	≤ 0.3 Ncm, at 20 °C		≤ 0.6 Ncm, at 20 °C	

	Solid shaft servo flange	Solid shaft face mount flange	Blind hollow shaft	Through hollow shaft
Permissible load capacity of shaft	80 N (radial) 40 N (axial)		-	
Permissible shaft movement, static	-		± 0.3 mm (radial) ± 0.5 mm (axial)	
Permissible shaft movement, dynamic	-		± 0.05 mm (radial) ± 0.1 mm (axial)	
Moment of inertia of the rotor	8 gcm ²		56 gcm ²	
Bearing lifetime	3.6 × 10 ⁹ revolutions ^{3) 4)}			
Angular acceleration	≤ 500,000 rad/s ²			
Operating speed	≤ 9,000 min ⁻¹		≤ 6,000 min ⁻¹	

1) For singleturn variant only.

2) Related to devices with plug connection.

3) The mission time can also be limited by the bearing service life specific to the application.

4) The value corresponds to L_{10 mr} (ISO/TS 16281) at 10 °C to 60 °C operating temperature, max. speed, at max. permissible shaft loading/shaft movement.

Table 15: Technical data- ambient data

	Solid shaft servo flange	Solid shaft face mount flange	Blind hollow shaft	Through hollow shaft
EMC	EN 61000-6-2 EN 61000-6-3 EN 61000-6-7			
Enclosure rating	IP65 (IEC 60529)			
Permissible relative humidity	90% (condensation of optical surfaces not permitted)			
Operating temperature range (for each variant)				
Male connector, M23, 12-pin	-30 °C ... +95 °C ¹⁾			
Male connector, M12, 12-pin	-30 °C ... +85 °C ¹⁾			
Cable, 12-wire	-30 °C ... +85 °C ¹⁾			
Storage temperature range	-30 °C ... +85 °C, without packaging			
Resistance to shocks	100 g, 6 ms (according to IEC 60068-2-27) ²⁾			
Resistance to vibrations (for each variant)				
Male connector, M23, 12-pin	30 g, 10 Hz ... 1,000 Hz (EN 60068-2-6) ²⁾		10 g, 10 Hz ... 1,000 Hz (EN 60068-2-6) ²⁾	
Male connector, M12, 12-pin	30 g, 10 Hz ... 1,000 Hz (EN 60068-2-6) ²⁾		18 g, 10 Hz ... 1,000 Hz (EN 60068-2-6) ²⁾	
Cable, 12-wire	30 g, 10 Hz ... 1,000 Hz (EN 60068-2-6) ²⁾		18 g, 10 Hz ... 1,000 Hz (EN 60068-2-6) ²⁾	
Operating height (above sea level)	≤ 2,000 m (80 kPa)			
Protection class	III (in accordance with IEC 61140)			
Contamination rating	2 (in accordance with IEC 60664-1)			

1) At the operating temperature measuring point.

2) Tested during operation within the safety-related accuracy. The following applies to the hollow shaft variants: [section 4.2.1](#).

Table 16: Technical data - safety-related characteristic values

Safety integrity level	SIL3 (IEC 61508, IEC 61800-5-3) ¹⁾
Performance level	PL e (EN ISO 13849-1) ¹⁾
Category	3 (EN ISO 13849-1) 4 (EN ISO 13849-1)
PFH _D : Probability of dangerous failure per hour	5.5 × 10 ⁻⁹ , at 40 °C ²⁾ 1.8 × 10 ⁻⁸ , at 80 °C ²⁾

T_M (mission time) ³⁾	20 years (EN ISO 13849-1)
Safety-related accuracy ⁴⁾	0.09° Category 3 0.35° Category 4

- 1) For more detailed information on the exact configuration of your machine/unit, please consult your relevant SICK branch office.
- 2) The values displayed apply to the temperature at the operating temperature measuring point and to a diagnostic degree of coverage of 99%, which must be achieved by the external evaluation unit, see "Requirements on diagnostics and error detection", page 17.
- 3) The mission time can also be limited by the bearing service life specific to the application.
- 4) The safety related accuracy indicates the maximum positioning error limit with which the safety functions can be supported.

13.1 Max. speed consideration

The following resolutions can be achieved depending on the frequency:

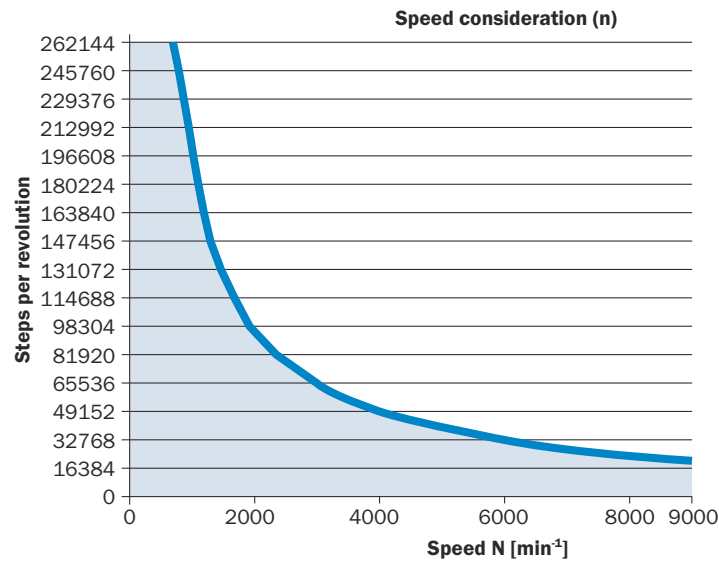

Figure 31: Max. speed consideration depending on the number of increments per revolution

13.2 Dimensional drawings (all dimensions in mm)



NOTE

General tolerances according to DIN ISO 2768-mk



NOTE

Cable diameter 6.8 ± 0.3 mm; bend radius: min. 10 x outer diameter of the cable

- 1 Operating temperature measuring point (freely selectable, in each case circumferential at the housing surface, approx. 3 mm from the flange)
- 2 Vibration measuring point (in each case at the housing front face, approx. 3 mm from the edge of the housing)

Table 17: Shaft diameter

XF7 shaft diameter	XF7 shaft diameter
6 mm	Provided by customer
8 mm	
3/8"	
10 mm	
12 mm	
1/2"	
14 mm	
15 mm	
5/8"	

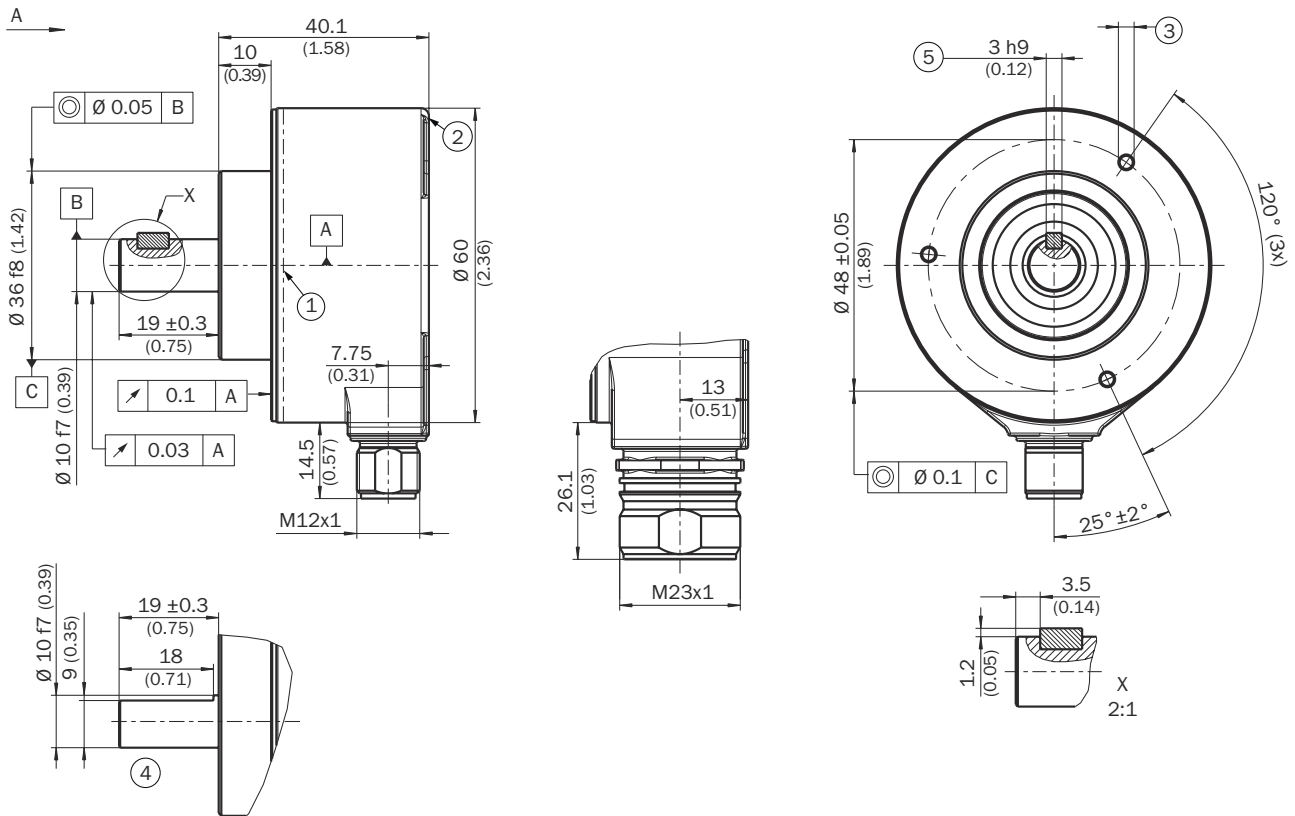

Figure 32: Solid shaft encoder dimensional drawing with face mount flange and radial connection

- ① Operating temperature measuring point (freely selectable, in each case circumferential at the housing surface, approx. 3 mm from the flange)
- ② Vibration measuring point (in each case at the housing front face, approx. 3 mm from the edge of the housing)
- ③ M3 / M4 (3x) (6 mm deep)
- ④ Shaft with flat
- ⑤ Square key, DIN 6885-A 3x3x6

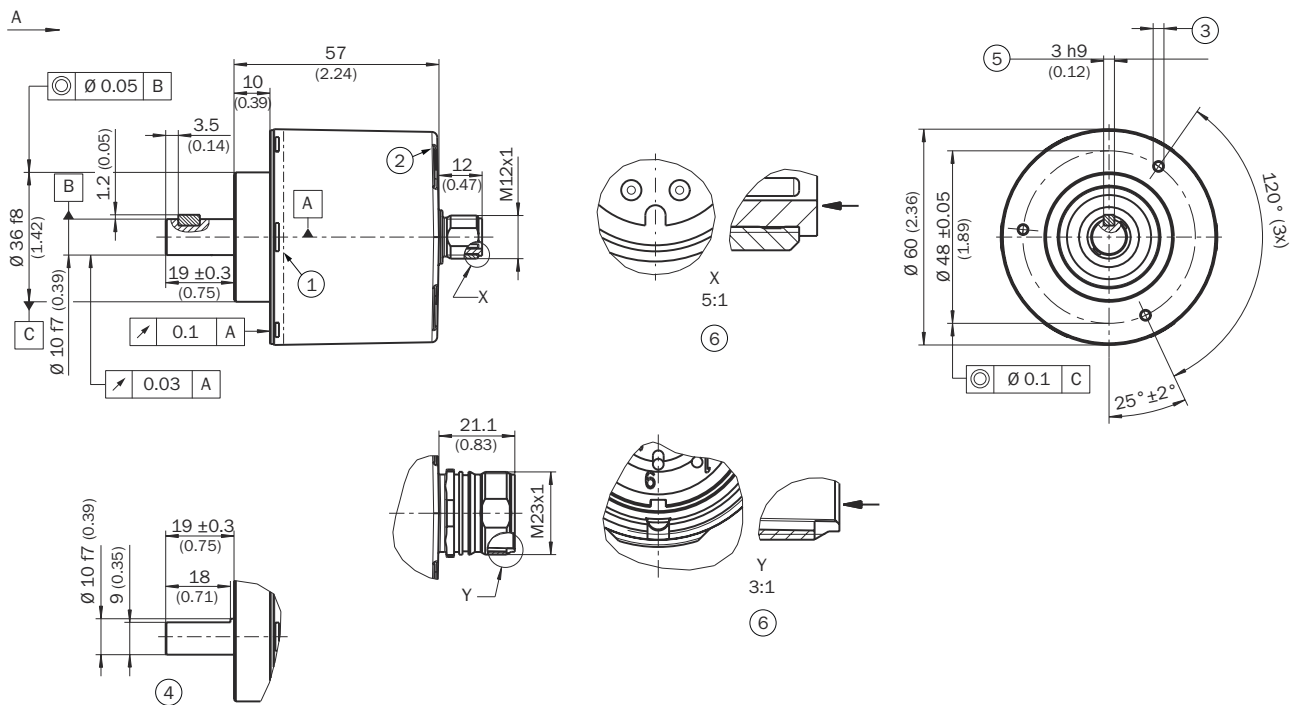

Figure 33: Solid shaft encoder dimensional drawing with face mount flange and axial connection

- ① Operating temperature measuring point (freely selectable, in each case circumferential at the housing surface, approx. 3 mm from the flange)
- ② Vibration measuring point (in each case at the housing front face, approx. 3 mm from the edge of the housing)
- ③ M3 / M4 (3x) (6 mm deep)
- ④ Shaft with flat
- ⑤ Square key, DIN 6885-A 3x3x6
- ⑥ Male connector orientation

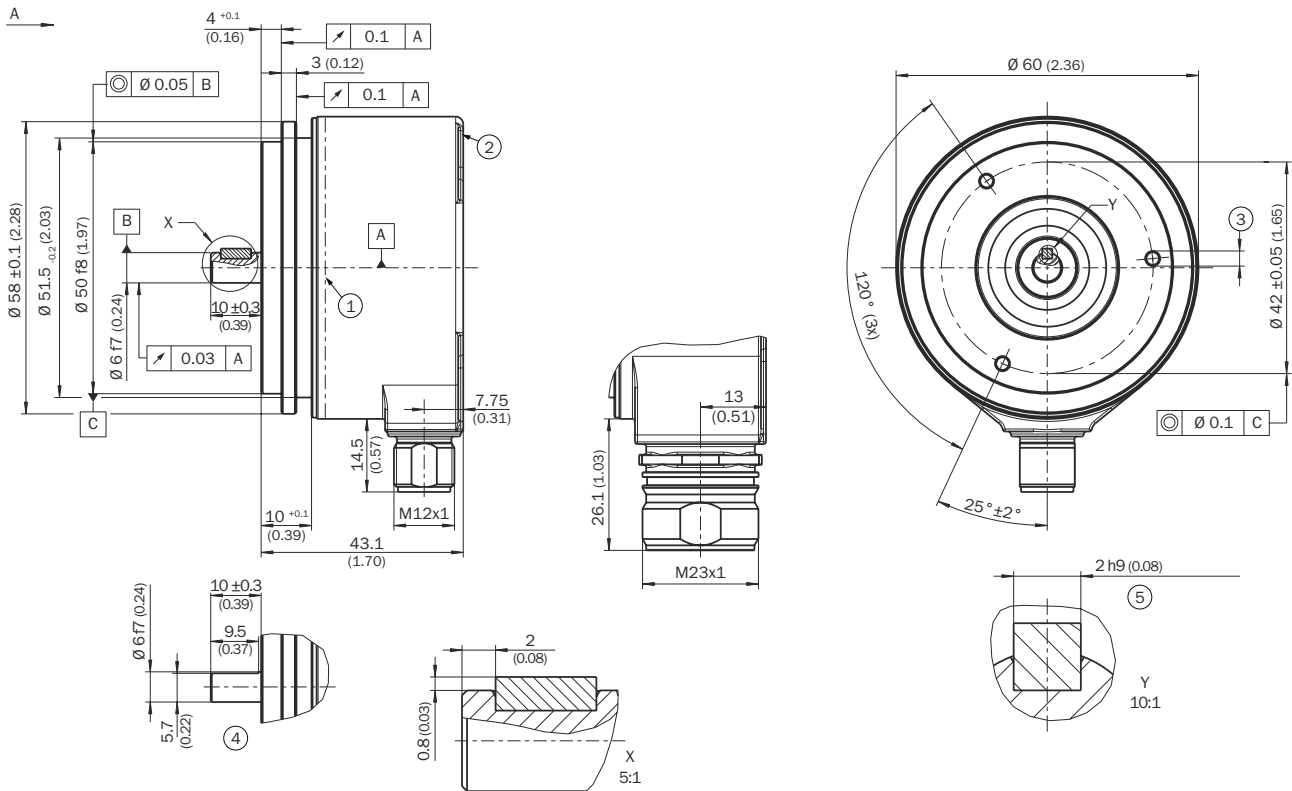

Figure 34: Solid shaft encoder dimensional drawing with servo flange and radial connection

- ① Operating temperature measuring point (freely selectable, in each case circumferential at the housing surface, approx. 3 mm from the flange)
- ② Vibration measuring point (in each case at the housing front face, approx. 3 mm from the edge of the housing)
- ③ M3 / M4 (3x) (6 mm deep)
- ④ Shaft with flat
- ⑤ Square key

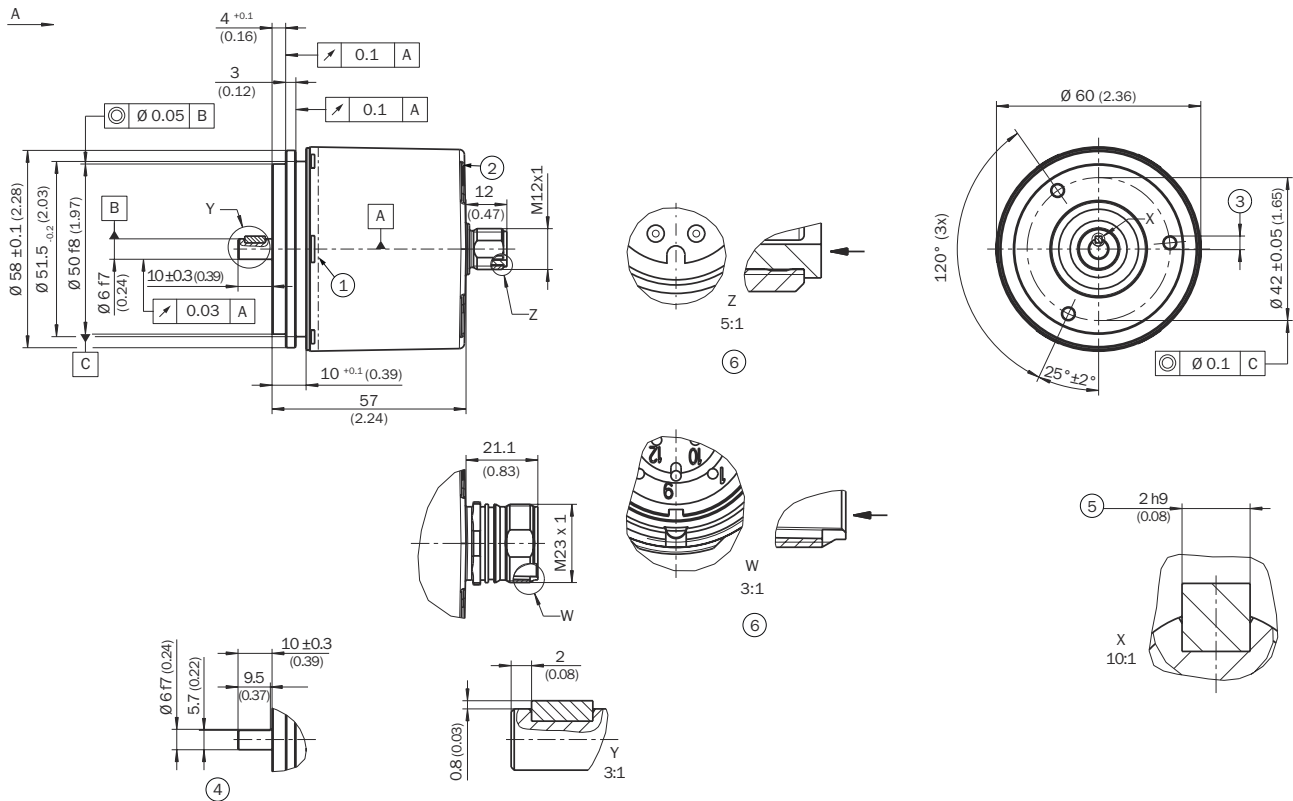

Figure 35: Solid shaft encoder dimensional drawing with servo flange and axial connection

- ① Operating temperature measuring point (freely selectable, in each case circumferential at the housing surface, approx. 3 mm from the flange)
- ② Vibration measuring point (in each case at the housing front face, approx. 3 mm from the edge of the housing)
- ③ M3 / M4 (3x) (6 mm deep)
- ④ Shaft with flat
- ⑤ Square key, DIN 6885-A 2x2x6
- ⑥ Male connector orientation

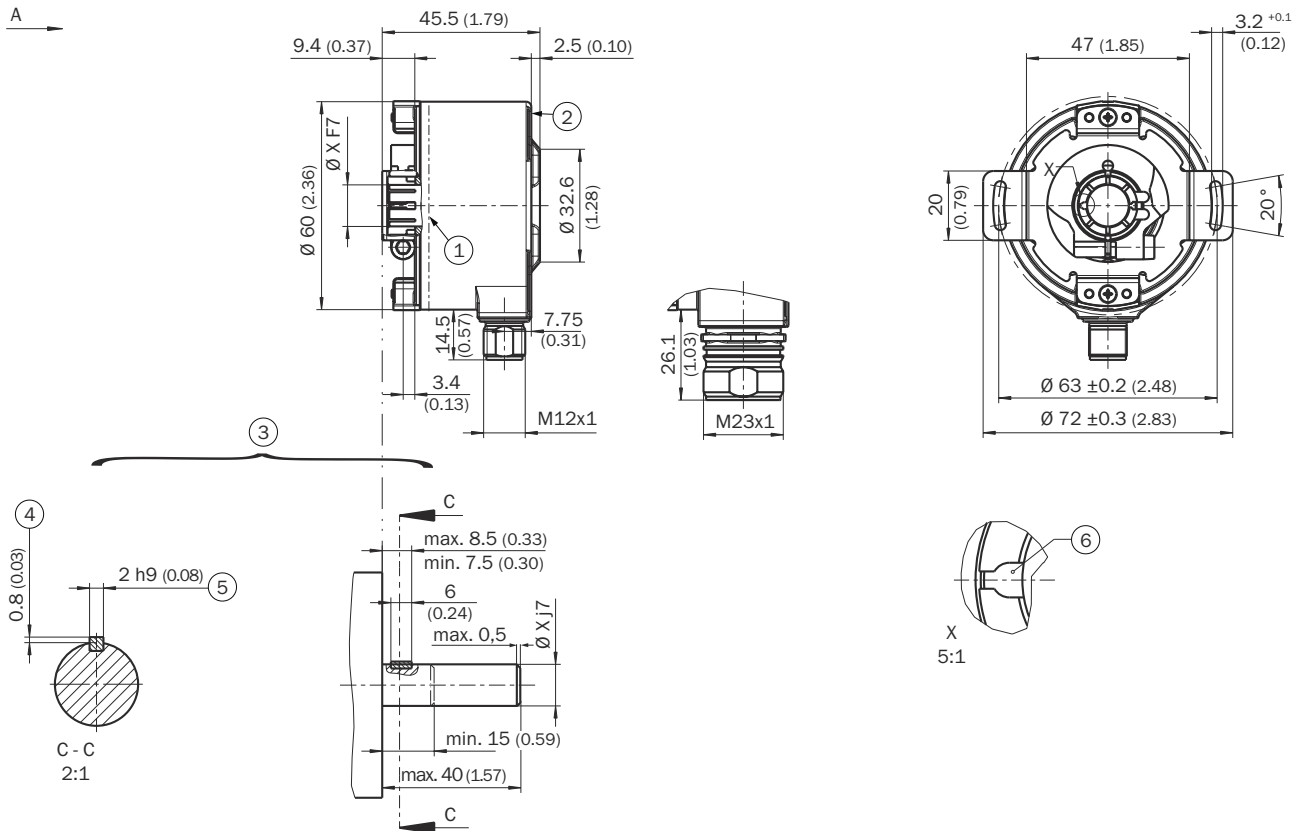

Figure 36: Blind hollow shaft encoder dimensional drawing

- ① Operating temperature measuring point (freely selectable, in each case circumferential at the housing surface, approx. 3 mm from the flange)
- ② Vibration measuring point (in each case at the housing front face, approx. 3 mm from the edge of the housing)
- ③ Attachment specifications
- ④ Max. 0.4 at $\varnothing 5/8"$
- ⑤ Square key, DIN 6885-A 2x2x6
- ⑥ Square key groove

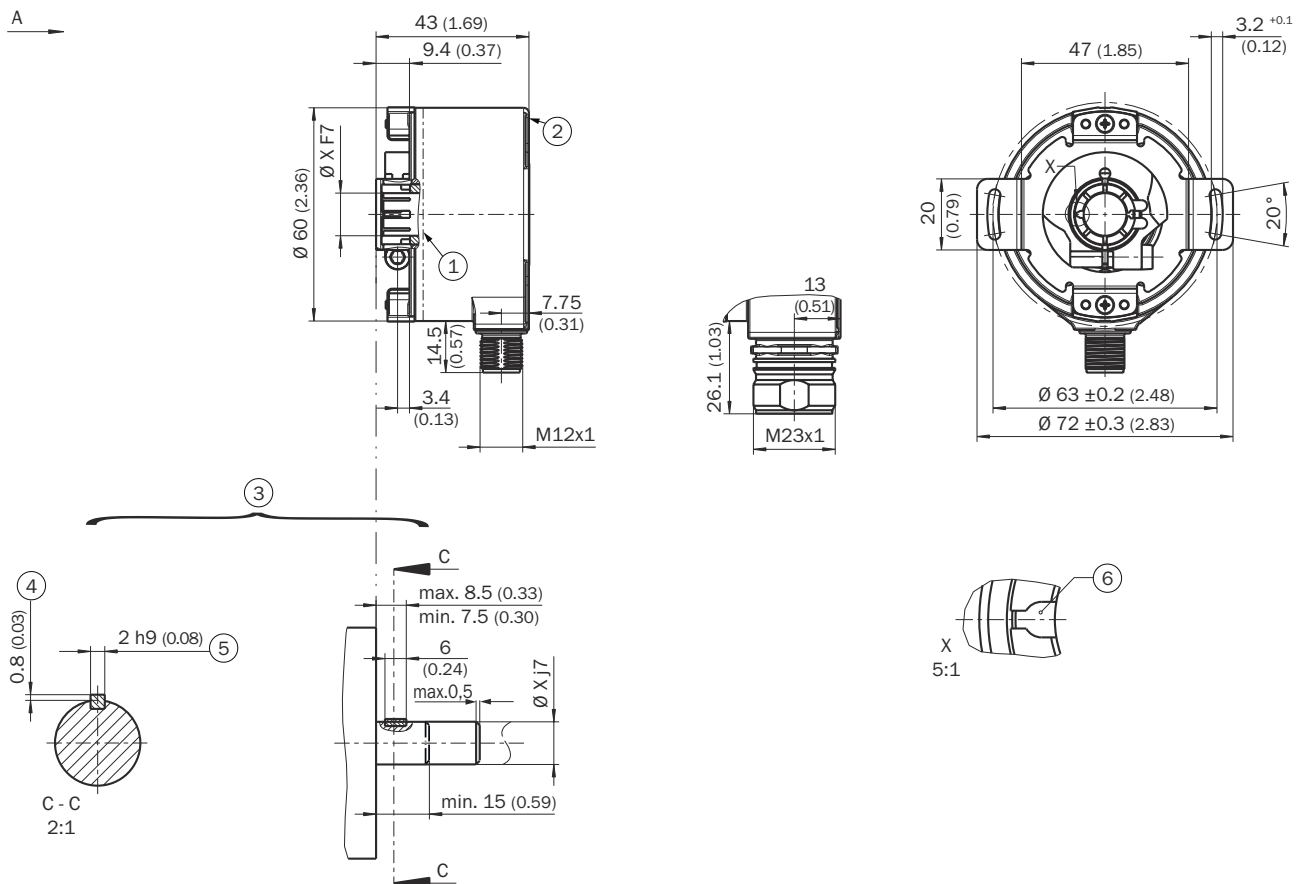

Figure 37: Through hollow shaft encoder dimensional drawing

- ① Operating temperature measuring point (freely selectable, in each case circumferential at the housing surface, approx. 3 mm from the flange)
- ② Vibration measuring point (in each case at the housing front face, approx. 3 mm from the edge of the housing)
- ③ Attachment specifications
- ④ Max. 0.4 at $\varnothing 5/8$ "
- ⑤ Square key, DIN 6885-A 2x2x6
- ⑥ Square key groove

14 **Ordering information**

14.1 **Scope of delivery**

- AFS/AFM60S Pro safety encoder
- Feather key in accordance with DIN 6885-A (for hollow shaft variant)
- T20 Torx screw for clamping ring (for hollow shaft variant)
- Additional "HOT SURFACE" label
- General safety notes
- Mounting instructions

15 Accessories



NOTE

The accessories are part of the safety-related function chain and must be assessed and validated accordingly by the user. Any accessory not listed in this Chapter will not be included in the safety assessment carried out by SICK AG.

Table 18: Accessories

Part	Part no.
BEF-WK-SF servo clamps, large (set of 3)	2029166
BEF-WK-SF servo clamps, half-shells (2 pcs.)	2029165
PGT-08-S programming interface	1036616
M12 connecting cable PGT-08-S	2088790
M23 connection cable PGT-08-S	2059270
BEF-MK-SE01 Cylinder head screw M4x16 and feather key 2x2x6 (1 pc.)	2073617

16 Annex

16.1 Conformities and certificates

You can obtain declarations of conformity, certificates, and the current operating instructions for the product at www.sick.com. To do so, enter the product part number in the search field (part number: see the entry in the “P/N” or “Ident. no.” field on the type label).

16.1.1 Compliance with EU directives

EU declaration of conformity (extract)

The undersigned, representing the manufacturer, herewith declares that the product is in conformity with the provisions of the following EU directive(s) (including all applicable amendments), and that the standards and/or technical specifications stated in the EU declaration of conformity have been used as a basis for this.

- MACHINERY DIRECTIVE 2006/42/EC
- EMC DIRECTIVE 2014/30/EU
- ROHS DIRECTIVE 2011/65/EU

16.1.2 Compliance with UK statutory instruments

UK declaration of conformity (extract)

The undersigned, representing the following manufacturer herewith declares that this declaration of conformity is issued under the sole responsibility of the manufacturer. The product of this declaration is in conformity with the provisions of the following relevant UK Statutory Instruments (including all applicable amendments), and the respective standards and/or technical specifications have been used as a basis.

- Electromagnetic Compatibility Regulations 2016
- Supply of Machinery (Safety) Regulations 2008
- Restriction of the Use of Certain Hazardous Substances in Electrical and Electronic Equipment Regulations 2012

Note: The certificate for this product covers the product itself and the accessories.

TYPE:
AFS60S / AFM60S

SICK

SICK Staggmann GmbH
Dürheimer Straße 36
78166 Donaueschingen
Germany

Ident-Nr.: 9311250

EU declaration of conformity en

The undersigned, representing the following manufacturer herewith declares that the product is in conformity with the provisions of the following EU directive(s) (including all applicable amendments), and that the respective standards and/or technical specifications have been used as a basis for this (download: www.sick.com).

You can obtain the EU declaration of conformity with the standards used at: www.sick.com

Directives used: MAS-Directive 2006/42/EC
EMC-Directive 2014/30/EU
RoHS Directive 2011/65/EU

Date: 2020-03-25

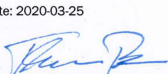
 I.V. Thomas Braun
Head of Business Unit
Encoders
(GBC Motion Control Sensors)
authorized for technical documentation

 I.V. Markus Mucha
Head of Operations
(GBC Motion Control Sensors)

EU-Konformitätserklärung de

Der Unterzeichner, der den nachstehenden Hersteller vertritt, erklärt hiermit, dass das Produkt in Übereinstimmung mit den Bestimmungen der nachstehenden EU-Richtlinie(n) (einschließlich aller zutreffenden Änderungen) ist, und dass die entsprechenden Normen und/oder technischen Spezifikationen zugrunde gelegt sind (Download: www.sick.com).

ЕС декларация за съответствие bg

Подписаният, който представя долуупомнатия производител, обявява, че продуктът съответства на разпоредбите на долуизброените директиви на ЕС (включително на всички действащи изменения) и че се базира на съответните норми и/или технически спецификации за приложение (Изтегляне: www.sick.com).

Prohlášení o shodě EU cs

Níže podepsaný, zastupující následujícího výrobce, tímto prohlašuje, že výrobek je v souladu s ustanoveními následující(ch) směrnice (směrnic) EU (včetně všech platných změn) a že podkladem byly odpovídající normy a/nebo technické specifikace. (Ke stažení: www.sick.com).

EU-oversenstemmelseerklæring da

Undertegnede, der repræsenterer følgende producent, erklærer hermed, at produktet er i overensstemmelse med bestemmelserne i følgende EU-direktiv(er) (inklusive alle gældende ændringer), og at alle tilsvarende standarder og/eller tekniske specifikationer er blevet anvendt (download: www.sick.com).

ΕΕ-Δήλωση συμμόρφωσης el

Ο Υπογράφων, εκπροσωπών τον ακόλουθο κατασκευαστή, δηλώνει με το παρόν έγγραφο ότι το προϊόν συμμορφώνεται με τους όρους της(των) ακόλουθης(ων) Οδηγία(ών) της ΕΕ (συμπεριλαμβανομένων όλων των εφαρμοζόμενων τροποποιήσεων) και ότι έχουν ληφθεί υπόψη τα αντίστοιχα πρότυπα ή/και οι τεχνικές προδιαγραφές (Μήτρη: www.sick.com).

Declaración de conformidad de la UE es

El abajo firmante, en representación del fabricante indicado a continuación, declara que el producto es conforme con las disposiciones de la(s) siguiente(s) directiva(s) de la UE (incluyendo todas las modificaciones aplicables) y que las respectivas normas y/o especificaciones técnicas han sido utilizadas como base. (Download: www.sick.com).

EL vastavuseklaratsioon et

Allakirjutanu, kes esindab järgmist tootjat, kinnitab käesolevaga, et antud toode vastab järgneva(te) EL-i direktiivi(de) sätetele (kaasa arvatud kõikidele asjakohastele muudatustele) ja et on rakendatud vastavaid nõudeid ja/või tehnilisi kirjeldusi. (Allalaadimine: www.sick.com).

EU-vaatimustenmukaisuusvakuutus fi

Allakirjoittanut, joka edustaa alla mainittua valmistajaa, vakuuttaa täten, että tuote on seuraavan (ien) EU-direktiivin (ien) vaatimusten mukainen (mukaan lukien kaikki sovellettavat muutokset) ja että sen perustana ovat vastaavat standardit ja tekniset erittelyt (Latausosoite: www.sick.com).

Déclaration de conformité UE fr

Le soussigné, représentant le constructeur ci-après, déclare par la présente que le produit est conforme aux exigences de la (des) directive(s) de l'UE suivantes (y compris tous les amendements applicables) et que les normes et/ou spécifications techniques correspondantes ont servi de base (téléchargement: www.sick.com).

Izjava o skladnosti EU hr

Potpisnik, koji zastupa proizvođača navedenog u nastavku, ovime izjavljuje da je proizvod usklađen s odredbama dole navedenih direktiva EU-a (uključujući sve nastale izmjene) i da je u skladu s odgovarajućim normama i/ili tehničkim specifikacijama (preuzimanje: www.sick.com).

EU megfeleléségi nyilatkozat hu

Alulírott, az alábbi gyártó képviselőjeként ezennel kijelentem, hogy a termék megfelel az alábbi EU-irányelv(ek) követelményeinek (beleértve azok minden vonatkozó módosítását) és kijelentem, hogy a megfelelő szabványokat és/vagy műszaki előírásokat vette alapul. (Letöltés: www.sick.com).

ESB-samræmisýfirlýsing is

Undirritaður, fyrir hönd framleiðandans sem nefndur er hér að neðan, lýsir því hér með yfir að varan er í samræmi við ákvæði eftirtalinnna ESB-tilskipana (að meðtöldum öllum breytingum sem við eiga) og að þessu til grundvallar samræmist varan viðeigandi stöðlum og/óða tækniforskriftum (niðurhat: www.sick.com).

Dichiarazione di conformità UE it

Il sottoscritto, in qualità di rappresentante del costruttore sotto indicato, dichiara con la presente che il prodotto è conforme alle disposizioni della(e) seguente(i) direttiva(e) UE (comprese tutte le modifiche applicabili) e che si basa sulle rispettive norme e/o specifiche tecniche (scaricabili dal sito web: www.sick.com).

ES atiliktis deklaracija lt

Pasirašiusysis, atstovaujantis šiam gamint oji deklaruoja, kad gaminys atitinka šios (ių) ES direktyvos (ų) reikalavimus (įskaitant visus taikytinus keitinius) ir kad buvo remtasi antrajame puslapyje nurodytais standartais ir (arba) techninėmis specifikacijomis (atsisiųsti: www.sick.com).

ES atbilstības deklarācija lv

Apakšā parakstījusies persona, kas pārstāv zemāk minēto ražotāju, ar šo deklarē, ka izstrādājums atbilst zemāk minētajai (-ām) ES direktīvai (-ām) (ieskaitot visus atbilstošos grozījumus) un ka izstrādājuma izgatavošanā par pamatu ņemti attiecīgie standarti un/vai tehniskās specifikācijas (lejupielāde: www.sick.com).

EU-erklaring van overeenstemming nl

Ondergetekende, vertegenwoordiger van de volgende fabrikant, verklaart hiermee dat het product voldoet aan de bepalingen van de volgende EU-richtlijn(en) (inclusief alle van toepassing zijnde wijzigingen) en dat de overeenkomstige normen en/of technische specificaties als grondslag werden gebruikt (Download: www.sick.com).

EU-samsvarserklæring no

Undertegnede, som representerer nedennnevnte produsent, erklærer herved at produktet er i samsvar med bestemmelserne i følgende EU-direktiv(er) (inkludert alle relevante endringer) og at relevante normer og/eller tekniske spesifikasjoner er blitt anvendt (Nedlasting: www.sick.com).

Deklaracja zgodności UE pl

Niżej podpisany, reprezentujący wymienionego poniżej producenta oświadczam niniejszym, że wyrób jest zgodny z postanowieniami podanej/podanych poniżej dyrektyw/y UE (wraz z odnoszonymi poprawkami) oraz, że za podstawę wzięto odpowiednie normy i/lub specyfikacje techniczne (download: www.sick.com).

Declaração UE de conformidade pt

O abaixo assinado, que representa o seguinte fabricante, declara deste modo que o produto está em conformidade com as disposições da(s) seguinte(s) directiva(s) UE (incluindo todas as alterações aplicáveis) e que foram usadas como base as respectivas normas e/ou especificações técnicas. (Download: www.sick.com).

Declaratie de conformitate UE ro

Semnatarul, in calitate de reprezentant al producatorului numit mai jos, declara prin prezenta ca produsul este in conformitate cu prevederile directivei/lor UE enumerate mai jos (inclusiv cu toate modificarile aferente) si se intemeiaza pe normele si/sau specificatiile tehnice corespunzatoare (download: www.sick.com).

EÚ vyhlásenie o zhode sk

Dolu podpísaný zástupca výrobcu týmto vyhlasuje, že výrobok je v súlade s ustanoveniami nasledujúcej (nasledujúcich) smernice (smerníc) EÚ (vrátane všetkých platných zmien) a že ako základ boli použité príslušné normy a/alebo technické špecifikácie (Download: www.sick.com).

Izjava EU o skladnosti sl

Podpisani predstavnik spodaj navedenega proizvajalca izjavljam, da je proizvod v skladu z določbami spodaj navedenih direktiv EU (vključno z vsemi ustreznimi spremembami) in da so osnova ustrezni standardi in/ali tehnične specifikacije (prenos: www.sick.com).

EU-försäkran om överensstämmelse sv

Undertecknad, som representerar nedanstående tillverkare, försäkras härmed att produkten överensstämmer med bestämmelserna i följande EU-direktiv (inklusive samtliga tillämpliga tillägg till dessa) och baseras på relevanta standarder och/eller tekniska specifikationer (nedladdning: www.sick.com).

Figure 38: Declaration of conformity



UK Declaration of Conformity

Ident-No. : 9361038

The undersigned, representing the following manufacturer

SICK AG
Erwin-Sick-Straße 1
79183 Waldkirch
Germany

www.sick.com

herewith declares that this declaration of conformity is issued under the sole responsibility of the manufacturer.

The product

Type:	AFS60S / AFM60S
Product designation:	Safety Encoder

of this declaration is in conformity with the provisions of the following relevant UK Statutory Instruments (including all applicable amendments), and the respective standards and/or technical specifications have been used as a basis.

Waldkirch, 2022-05-12

i.V. Thomas Braun
Head of Business Unit Encoders R&D

i.V. Markus Mucha
Head of Operations & Facility Management
TOP/M

Australia

Phone +61 (3) 9457 0600
1800 33 48 02 – tollfree
E-Mail sales@sick.com.au

Austria

Phone +43 (0) 2236 62288-0
E-Mail office@sick.at

Belgium/Luxembourg

Phone +32 (0) 2 466 55 66
E-Mail info@sick.be

Brazil

Phone +55 11 3215-4900
E-Mail comercial@sick.com.br

Canada

Phone +1 905.771.1444
E-Mail cs.canada@sick.com

Czech Republic

Phone +420 234 719 500
E-Mail sick@sick.cz

Chile

Phone +56 (2) 2274 7430
E-Mail chile@sick.com

China

Phone +86 20 2882 3600
E-Mail info.china@sick.net.cn

Denmark

Phone +45 45 82 64 00
E-Mail sick@sick.dk

Finland

Phone +358-9-25 15 800
E-Mail sick@sick.fi

France

Phone +33 1 64 62 35 00
E-Mail info@sick.fr

Germany

Phone +49 (0) 2 11 53 010
E-Mail info@sick.de

Greece

Phone +30 210 6825100
E-Mail office@sick.com.gr

Hong Kong

Phone +852 2153 6300
E-Mail ghk@sick.com.hk

Hungary

Phone +36 1 371 2680
E-Mail ertebsites@sick.hu

India

Phone +91-22-6119 8900
E-Mail info@sick-india.com

Israel

Phone +972 97110 11
E-Mail info@sick-sensors.com

Italy

Phone +39 02 27 43 41
E-Mail info@sick.it

Japan

Phone +81 3 5309 2112
E-Mail support@sick.jp

Malaysia

Phone +603-8080 7425
E-Mail enquiry.my@sick.com

Mexico

Phone +52 (472) 748 9451
E-Mail mexico@sick.com

Netherlands

Phone +31 (0) 30 204 40 00
E-Mail info@sick.nl

New Zealand

Phone +64 9 415 0459
0800 222 278 – tollfree
E-Mail sales@sick.co.nz

Norway

Phone +47 67 81 50 00
E-Mail sick@sick.no

Poland

Phone +48 22 539 41 00
E-Mail info@sick.pl

Romania

Phone +40 356-17 11 20
E-Mail office@sick.ro

Singapore

Phone +65 6744 3732
E-Mail sales.gsg@sick.com

Slovakia

Phone +421 482 901 201
E-Mail mail@sick-sk.sk

Slovenia

Phone +386 591 78849
E-Mail office@sick.si

South Africa

Phone +27 10 060 0550
E-Mail info@sickautomation.co.za

South Korea

Phone +82 2 786 6321/4
E-Mail infokorea@sick.com

Spain

Phone +34 93 480 31 00
E-Mail info@sick.es

Sweden

Phone +46 10 110 10 00
E-Mail info@sick.se

Switzerland

Phone +41 41 619 29 39
E-Mail contact@sick.ch

Taiwan

Phone +886-2-2375-6288
E-Mail sales@sick.com.tw

Thailand

Phone +66 2 645 0009
E-Mail marcom.th@sick.com

Turkey

Phone +90 (216) 528 50 00
E-Mail info@sick.com.tr

United Arab Emirates

Phone +971 (0) 4 88 65 878
E-Mail contact@sick.ae

United Kingdom

Phone +44 (0)17278 31121
E-Mail info@sick.co.uk

USA

Phone +1 800.325.7425
E-Mail info@sick.com

Vietnam

Phone +65 6744 3732
E-Mail sales.gsg@sick.com

Detailed addresses and further locations at www.sick.com