



WLL80P-22T6Y2DZA71Z1Z1

WLL80

FIBER-OPTIC SENSORS

SICK
Sensor Intelligence.



Illustration may differ



Ordering information

Type	part no.
WLL80P-22T6Y2DZA71Z1Z1	6084904

Included in delivery: BEF-WLL180 (1)

Other models and accessories → www.sick.com/WLL80

Detailed technical data

Features

Device type	Fiber-optic amplifier
Device type detail	Stand-alone
Functional principle detail	Depending on the optical fiber cable used
Sensing range max.	Depending on the optical fiber cable used
Emitted beam	
Light source	LED
Type of light	Visible red light
Key LED figures	
Normative reference	EN 62471:2008-09 IEC 62471:2006, modified
LED risk group marking	Free group
Wave length	660 nm
Average service life	100,000 h at T _a = +25 °C
Adjustment	
IO-Link	For configuring the sensor parameters and Smart Task functions
Wire/pin	For deactivating the sender and executing the test logic/for setting the sensing range/for resetting the counter
Display + operating buttons	For configuring the sensor parameters
Display	
LED green	Operating indicator Static on: power on Flashing: IO-Link mode
LED yellow 1	Status of received light beam

	LED yellow 2	Static on: object present Static off: object not present Flashing: Executing teach-in/teach-in error
	Display	Status of received light beam Static on: object present Static off: object not present Flashing: Executing teach-in/teach-in error
	Display	Display of sensor functions Menu languages. German, English, Chinese, Korean, Japanese
Special features		Reduced scanning range to avoid operation in the saturation range
Items supplied		BEF-WLL180 mounting bracket

Safety-related parameters

MTTF_D	324.1 years
DC_{avg}	0%
T_M (mission time)	20 years

Communication interface

IO-Link	✓, IO-Link V1.1
Data transmission rate	COM3 (230.4 kbit/s)
Cycle time	0.5 ms
Process data length	32 Bit
Process data structure	Bit 0 = switching signal Q _{L1} Bit 1 = switching signal Q _{L2} Bit 2 = detection signal Q _{int.1} Bit 3 = detection signal Q _{int.2} Bit 16 ... 31 = Current receiver level (live)
Compatible master port type	A
SIO mode support	Yes

Electronics

Supply voltage U_B	12 V DC ... 30 V DC ^{1) 2)}
Ripple	± 10 % ³⁾
Current consumption	≤ 50 mA ⁴⁾
Protection class	III
Digital output	
Number	2 (individually adjustable)
Type	Push-pull: PNP/NPN ⁵⁾ PNP NPN: open collector
Switching mode	Light/dark switching

¹⁾ Limit values.

²⁾ IO-Link mode: 18 VDC ... 30 VDC.

³⁾ May not fall below or exceed U_y tolerances.

⁴⁾ Without load.

⁵⁾ Selectable via menu.

⁶⁾ With light/dark ratio 1:1.

Signal voltage PNP HIGH/LOW	Approx. $U_B - 2.5 \text{ V} / 0 \text{ V}$
Signal voltage NPN HIGH/LOW	Approx. $U_B / < 2.5 \text{ V}$
Output current I_{max}	$\leq 100 \text{ mA}$
Circuit protection outputs	Reverse polarity protected
	Overcurrent protected
	Short-circuit protected
Response time	$\leq 16 \mu\text{s}$
	$\leq 70 \mu\text{s}$
	$\leq 250 \mu\text{s}$
	$\leq 500 \mu\text{s}$
	$\leq 1,000 \mu\text{s}$
	$\leq 2,000 \mu\text{s}$
	$\leq 8,000 \mu\text{s}$
Switching frequency	31.2 kHz ⁶⁾
	7.1 kHz
	2 kHz
	1 kHz
	500 Hz
	250 Hz
	62.5 Hz
Time functions	Switch-on delay, off delay, ON and OFF delay, Impulse (one shot), Switch-on delay and pulse, deactivated
Delay time	Adjustment via operating buttons / via IO-Link, 0 ms ... 30,000 ms
Pin/Wire assignment	
Function of pin 4/black (BK)	Digital output, object present → Output Q_{L1} HIGH IO-Link communication C
Function of pin 4/black (BK) – detail	The pin 4 function of the sensor can be configured Additional possible settings via IO-Link
Function of pin 2/white (WH)	Digital output, object present → Output Q_{L2} HIGH
Function of pin 2/white (WH) – detail	The pin 2 function of the sensor can be configured Additional possible settings via IO-Link

¹⁾ Limit values.

²⁾ IO-Link mode: 18 VDC ... 30 VDC.

³⁾ May not fall below or exceed U_V tolerances.

⁴⁾ Without load.

⁵⁾ Selectable via menu.

⁶⁾ With light/dark ratio 1:1.

Mechanics

Housing	Rectangular
Dimensions (W x H x D)	10.5 mm x 33.2 mm x 79.9 mm
Connection	Male connector M8, 4-pin
Material	
Housing	Plastic, PC

Protection hood	Plastic, PC
Operating buttons	Plastic, Rubber
Male connector	Metal, nickel-plated brass
Weight	Approx. 24 g

Ambient data

Enclosure rating	IP54 (EN 60529)
Ambient operating temperature	-25 °C ... +55 °C
Ambient temperature, storage	-40 °C ... +70 °C
Typ. Ambient light immunity	Artificial light: ≤ 16,000 lx Sunlight: ≤ 67,000 lx
Shock resistance	50 g, 11 ms (3 positive and 3 negative shocks along X, Y, Z axes, 18 total shocks (EN60068-2-27))
Vibration resistance	10 Hz ... 55 Hz (Amplitude 1 mm, 3 x 30 min (EN60068-2-6))
Air humidity	35 % ... 85 %, relative humidity (no condensation)
Electromagnetic compatibility (EMC)	EN 60947-5-2

Smart Task

Smart Task name	Counter + debouncing
Logic function	Direct WINDOW Hysteresis
Timer function	Deactivated Switch-on delay Off delay ON and OFF delay Impulse (one shot) Switch-on delay and pulse
Inverter	Yes
Switching signal	
Switching signal Q _{L1}	Switching output
Switching signal Q _{L2}	Switching output

Diagnosis

Quality of run	Yes
-----------------------	-----

Certificates

EU declaration of conformity	✓
UK declaration of conformity	✓
ACMA declaration of conformity	✓
Moroccan declaration of conformity	✓
China RoHS	✓
cULus certificate	✓
IO-Link certificate	✓
Photobiological safety (DIN EN 62471) certificate	✓
Information according to Art. 3 of Data Act (Regulation EU 2023/2854)	✓

Classifications

ECLASS 5.0	27270905
ECLASS 5.1.4	27270905
ECLASS 6.0	27270905
ECLASS 6.2	27270905
ECLASS 7.0	27270905
ECLASS 8.0	27270905
ECLASS 8.1	27270905
ECLASS 9.0	27270905
ECLASS 10.0	27270905
ECLASS 11.0	27270905
ECLASS 12.0	27270905
ETIM 5.0	EC002651
ETIM 6.0	EC002651
ETIM 7.0	EC002651
ETIM 8.0	EC002651
UNSPSC 16.0901	39121528

display and adjustment elements

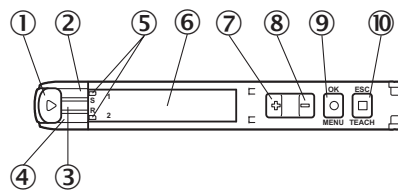

- ① Fiber optic interlock
- ② LED yellow 1
- ③ LED green
- ④ LED yellow 2
- ⑤ Indicator for correctly inserted fibers
- ⑥ Display
- ⑦ (+) button
- ⑧ (-) pushbutton
- ⑨ Menu/OK pushbutton
- ⑩ Teach-in/escape pushbutton

Connection type Male connector M8, 4-pin

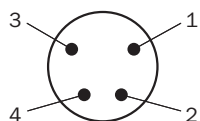

Connection diagram Cd-527

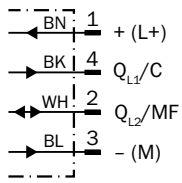

Dimensional drawing

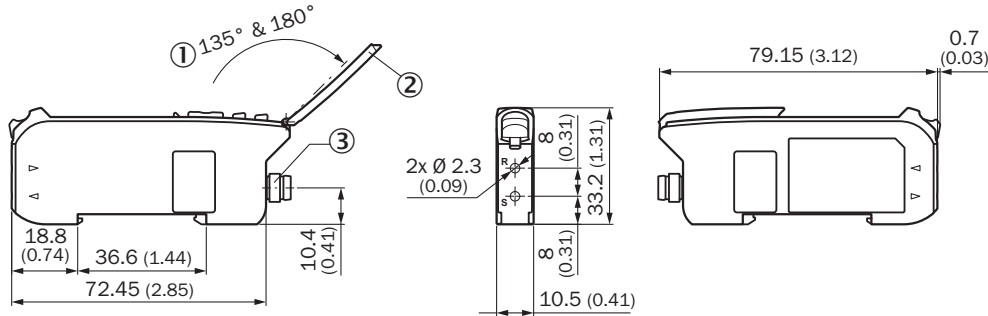

Dimensions in mm (inch)

- ① aperture angle
- ② Hinged cover for the pushbuttons
- ③ Connection

Recommended accessories

Other models and accessories → www.sick.com/WLL80

	Brief description	Type	part no.
fiber-optic sensors			
	<ul style="list-style-type: none"> • For fiber optic amplifiers: GLL70, WLL80, WLL180, GLL170(T) • Functional principle: Proximity system • Fiber length: 2,000 mm • Thread diameter (housing): M3 • Fiber material: Plastic • Jacket material: Plastic • Fiber head material: Stainless steel • Included with delivery: Mounting, 2 x M3 hexagon nut, 2 x washer, adapter sleeves, BF-WLL160-13 (1.3 mm) adapter sleeves, FC fiber cutter (5304141) 	LL3-DT01	5308076

SICK AT A GLANCE

SICK is one of the leading manufacturers of intelligent sensors and sensor solutions for industrial applications. A unique range of products and services creates the perfect basis for controlling processes securely and efficiently, protecting individuals from accidents and preventing damage to the environment.

We have extensive experience in a wide range of industries and understand their processes and requirements. With intelligent sensors, we can deliver exactly what our customers need. In application centers in Europe, Asia and North America, system solutions are tested and optimized in accordance with customer specifications. All this makes us a reliable supplier and development partner.

Comprehensive services complete our offering: SICK LifeTime Services provide support throughout the machine life cycle and ensure safety and productivity.

For us, that is “Sensor Intelligence.”

WORLDWIDE PRESENCE:

Contacts and other locations –www.sick.com