



LFC-XXSBTM

LFC

LEVEL SENSORS

SICK
Sensor Intelligence.



Ordering information

Type	part no.
LFC-XXSBTM	6077490

Other models and accessories → www.sick.com/LFC



Detailed technical data

Features

Medium	Fluids
Measurement	Switch
Process pressure	-1 bar ... 25 bar
Process temperature	-20 °C ... +100 °C ¹⁾

¹⁾ +135 °C for max. 1 h.

Performance

Reproducibility	± 1 mm
Response time	500 ms
Dielectricity constant	≥ 2
MTBF	7,3*10 ⁶ h

Electronics

Communication interface	IO-Link
Supply voltage	12 V DC ... 35 V DC ¹⁾
Residual ripple	≤ 5 V _{pp}
Power consumption	≤ 10 mA
Protection class	III
Connection type	M12 round connector x 1, 4-pin
Output signal	2 x PNP/NPN, IO-Link
Power consumption	≤ 0.1 W
Contamination rating	4

¹⁾ All connections are polarity protected. All outputs are overload and short-circuit protected.

²⁾ NEMA type 6P.

Inductive load	≤ 0.5 H
Capacitive load	100 nF
Enclosure rating	IP66 IP67 IP69 ²⁾
Overvoltage category	I
Load current	≤ 250 mA (Output permanently short-circuit proof)
Voltage drop	< 3 V
Switching voltage	< 34 V DC
Reverse current	< 10 µA
EMC	EN 61326-1

¹⁾ All connections are polarity protected. All outputs are overload and short-circuit protected.

²⁾ NEMA type 6P.

Mechanics

Wetted parts	PEEK ¹⁾
Process connection	G ½", DIN 3852-A / 316L
Housing material	Stainless steel 1.4404 / 316L, Plastic (Valox®)
Sealing material	NBR (male connector)

¹⁾ Sensor tip PEEK, polished.

Ambient data

Ambient operating temperature	-40 °C ... +70 °C
Ambient temperature, storage	-40 °C ... +80 °C

Classifications

ECLASS 5.0	27273290
ECLASS 5.1.4	27273290
ECLASS 6.0	27273290
ECLASS 6.2	27273290
ECLASS 7.0	27273290
ECLASS 8.0	27273290
ECLASS 8.1	27273290
ECLASS 9.0	27273290
ECLASS 10.0	27273290
ECLASS 11.0	27273290
ECLASS 12.0	27200503
ETIM 5.0	EC002654
ETIM 6.0	EC002654
ETIM 7.0	EC002654
ETIM 8.0	EC002654
UNSPSC 16.0901	41111950

Certificates

EU declaration of conformity	✓
-------------------------------------	---

UK declaration of conformity	✓
ACMA declaration of conformity	✓
FDA certificate	✓
cULus certificate	✓
cCSAus certificate	✓
IO-Link certificate	✓
Food contact material manufacturer declaration	✓
Information according to Art. 3 of Data Act (Regulation EU 2023/2854)	✓

Process connection PN 25, DIN 3852-A / 316L, unit: mm (inch), decimal separator: period

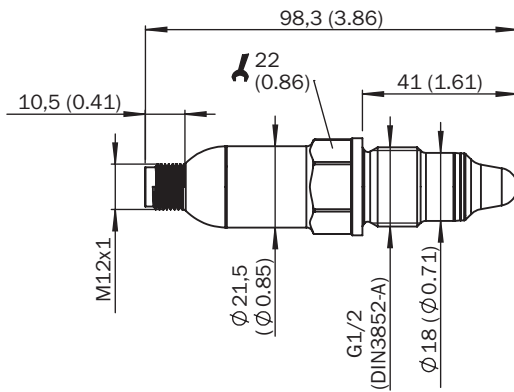

Dimensions in mm (inch)

SICK AT A GLANCE

SICK is one of the leading manufacturers of intelligent sensors and sensor solutions for industrial applications. A unique range of products and services creates the perfect basis for controlling processes securely and efficiently, protecting individuals from accidents and preventing damage to the environment.

We have extensive experience in a wide range of industries and understand their processes and requirements. With intelligent sensors, we can deliver exactly what our customers need. In application centers in Europe, Asia and North America, system solutions are tested and optimized in accordance with customer specifications. All this makes us a reliable supplier and development partner.

Comprehensive services complete our offering: SICK LifeTime Services provide support throughout the machine life cycle and ensure safety and productivity.

For us, that is “Sensor Intelligence.”

WORLDWIDE PRESENCE:

Contacts and other locations –www.sick.com