

SICK.COM



DATA SHEET

LBR-XXBXXCBHKXX

LBR SicWave
Level sensors

SICK Sensor Intelligence

LEVEL SENSORS

LBR-XXBXXCBHKXX

ORDERING INFORMATION

Type	part no.
LBR-XXBXXCBHKXX	6072112

Further device versions and accessories at www.sick.com/LBR_SicWave



DETAILED TECHNICAL DATA

FEATURES

Medium	Bulk solids
Measurement	Continuous
Probe type	Plastic horn antenna made from PP
Frequency band	W-band (within 75 ... 85 GHz)
Measuring range	Up to 120 m (393.7 ft), recommended measuring range in thread version with integrated horn antenna up to 20 m (65.62 ft)
Angle of dispersion	3.5° ¹⁾
Process pressure	-1 bar ... 2 bar (-100 kPa ... 200 kPa / -14.5 psig ... 29.1 psig)
Process temperature	-40 °C ... +80 °C
RoHS certificate	✓
HART	✓
Display	Without

¹⁾ Outside the specified aperture angle, the level of the radar signal energy is lowered by 50% (-3 dB).

PERFORMANCE

Accuracy of sensor element	≤ 5 mm ¹⁾
Non-repeatability	≤ 1 mm
Digital measurement resolution	< 1 mm

¹⁾ Measurement distance > 0.25 m / 0.8202 ft.

²⁾ Time span after abrupt change to the measurement distance by max. 2 m for bulk material applications until the output signal has assumed 90% of its steady-state value for the first time (IEC 61298-2).

Analog measurement resolution	0.3 μ A
Digital output temperature drift	≤ 3 mm / 10 K, max. 10 mm
Current output temperature drift	$\leq 0.03\%$ / 10 K relating to the 16 mA span or $\leq 0.3\%$
Deviation on current output due to digital-analog conversion	< 15 μ A
Measurement cycle time	Approx. 700 ms
Step response time	≤ 3 s ²⁾
MTBF	3,37*10 ⁶ h

¹⁾ Measurement distance > 0.25 m / 0.8202 ft.

²⁾ Time span after abrupt change to the measurement distance by max. 2 m for bulk material applications until the output signal has assumed 90% of its steady-state value for the first time (IEC 61298-2).

ELECTRONICS

Communication interface	HART
Supply voltage	9 V DC ... 30 V DC ¹⁾
Protection class	I (IEC 61010-1)
Connection type	M20 x 1.5 / plug connector M12 x 1 pin assignment B
Output signal	4 mA ... 20 mA / HART ²⁾
Contamination rating	4
Enclosure rating	IP67 / IP67
EMC	EN 61326-1
Start-up current	< 3.6 mA
Overvoltage category	III (IEC 61010-1)
Short-circuit protection	✓
Isolation	✓

¹⁾ All connections are polarity protected. All outputs are overload and short-circuit protected.

²⁾ Range of the output signal: 3.8 mA ... 20.5 mA / HART (factory setting); fault current < 3.6 mA or 22 mA.

MECHANICS

Process connection	Without process connection
Housing material	Aluminum die cast AlSi10Mg, powder-coated (base: polyester)
Housing design	Single-chamber housing
Sealing material	PP
Antenna material	PP

AMBIENT DATA

Ambient operating temperature	-40 °C ... $+80$ °C
Ambient temperature, storage	-40 °C ... $+80$ °C

LEVEL SENSORS - LBR-XXBXXCBHKXX

UNIT: MM (INCH), DECIMAL SEPARATOR: PERIOD

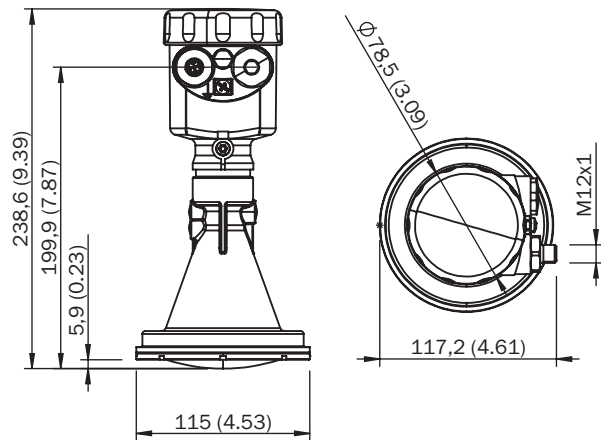

Dimensions in mm (inch)
LBR-xxBXXCBHKXX

Further information as well as suitable accessories, example applications and downloads such as CAD dimensional models, operating instructions and software can be found at www.sick.com/6072112



SICK AG
WALDKIRCH
GERMANY
SICK.COM

SICK AT A GLANCE

SICK is a leading global technology company for intelligent sensors and integrated solutions in industrial automation. Our technologies set benchmarks, making your industrial processes more efficient, safer and more sustainable – both in logistics and manufacturing operations.

SICK combines sensor intelligence with industry expertise and certified consulting services. We provide the ideal foundation for scalable as well as tailor-made automation solutions and create added value along the entire value chain. Our close partnerships with our customers are more than just a promise: Together, we optimize productivity, improve quality, protect health and safety, and help build a sustainable future. All with empathy and trust.

Since 1946, we have been developing innovative technologies with passion and a pioneering spirit. With a global network in around 40 countries, SICK has a global presence and is always close by. The company's headquarters are located in Waldkirch near Freiburg, Germany. Our customers benefit from our understanding of both local and global requirements, which enables us to deliver tailor-made solutions

SICK
Sensor Intelligence