

SICK.COM



DATA SHEET

TR110-SRUSA00

TR110 Lock
Safety locking devices

SICK Sensor Intelligence

SAFETY LOCKING DEVICES

TR110-SRUSA00

ORDERING INFORMATION

Type	part no.
TR110-SRUSA00	6033743

Further device versions and accessories at www.sick.com/TR110_Lock



DETAILED TECHNICAL DATA

FEATURES

Sensor principle	RFID
Locking principle	Power to release
Coding	Uniquely coded
Locking force F_{max}	With straight actuator 3,900 N (EN ISO 14119) With angled actuator 1,500 N (EN ISO 14119) With hinged actuator 2,600 N (EN ISO 14119)
Locking force F_{zh}	With straight actuator 3,000 N (EN ISO 14119) With angled actuator 1,100 N (EN ISO 14119) With hinged actuator 2,000 N (EN ISO 14119)
Actuation force	≥ 10 N
Retaining force	20 N
Force against which unlocking is possible	≤ 20 N
Actuation frequency	≤ 0.5 Hz
Approach speed	≤ 20 m/min

SAFETY-RELATED PARAMETERS

Safety integrity level	SIL 3 (IEC 61508)
Category	Category 4 (EN ISO 13849) ¹⁾
Performance level	PL e (EN ISO 13849) ¹⁾

¹⁾ Applies for monitoring of the door position (interlocking monitoring) and locking monitoring.

PFH _D (mean probability of a dangerous failure per hour)	4.1 x 10 ⁻⁹ ¹⁾
T _M (mission time)	20 years (EN ISO 13849)
Type	Type 4 (EN ISO 14119)
Actuator coding level	High coding level (EN ISO 14119)
Safe state in the event of a fault	At least one safety-related semiconductor output (OSSD) is in the OFF state.

¹⁾ Applies for monitoring of the door position (interlocking monitoring) and locking monitoring.

FUNCTIONS

Switching behavior of the OSSDs	Locking monitoring
Safe series connection	None, only individual wiring (with diagnostics)

INTERFACES

Connection type	Plug connector, M12, 8-pin
Coupling nut material	Brass
Display elements	LEDs
Diagnostics indicator	✓
Status display	✓

ELECTRONICS

Protection class	III (IEC 61140)
Contamination rating	3 (EN 60947-1)
Classification according to cULus	Class 2
Usage category	DC-13 (IEC 60947-5-1)
Rated operating current (voltage)	150 mA (24 V DC) ¹⁾
Rated insulation voltage U _i	50 V
Rated impulse withstand voltage U _{imp}	500 V
Supply voltage V _s	Sensor 24 V DC (20.4 V DC ... 27.6 V DC) Magnet 24 V DC (20.4 V DC ... 26.4 V DC)
Power consumption	Sensor 40 mA Magnet 400 mA
Type of output	Self-monitoring semiconductor outputs (OSSDs) Safety outputs 2 semiconductor outputs (OSSDs), p-switching, short-circuit protected Application diagnostic outputs P-switching, short-circuit protected
Output current	Safety outputs 1 mA ... 150 mA Application diagnostic outputs 1 mA ... 50 mA
Power consumption of magnet	6 W
Switch-on time of magnet	100 %
Response time	≤ 260 ms ²⁾
Release time	400 ms
Switch-on time	1 s
Discrepancy time	10 ms (EN IEC 60947-5-3)
Locking principle	Power to release

¹⁾ In the case of inductive loads, outputs must be protected with a freewheeling diode.

²⁾ 5 ms for each additional switch.

MECHANICS

Weight	0.42 kg
Material	Switch head Zinc diecast Housing Glass-fiber reinforced thermoplastic Plug connectors Nickel-plated brass
Mechanical life	1 x 10 ⁶ switching cycles

AMBIENT DATA

Enclosure rating	IP67 (EN 60529) IP69K
Ambient operating temperature	-20 °C ... +55 °C
Vibration resistance	10 Hz ... 55 Hz (IEC 60068-2-6)
Shock resistance	30 g, 11 ms (EN 60068-2-27)
EMC	EN IEC 60947-5-3

CERTIFICATES

EU declaration of conformity	✓
UK declaration of conformity	✓
ACMA declaration of conformity	✓
China RoHS	✓
cULus certificate	✓

DIMENSIONAL DRAWING

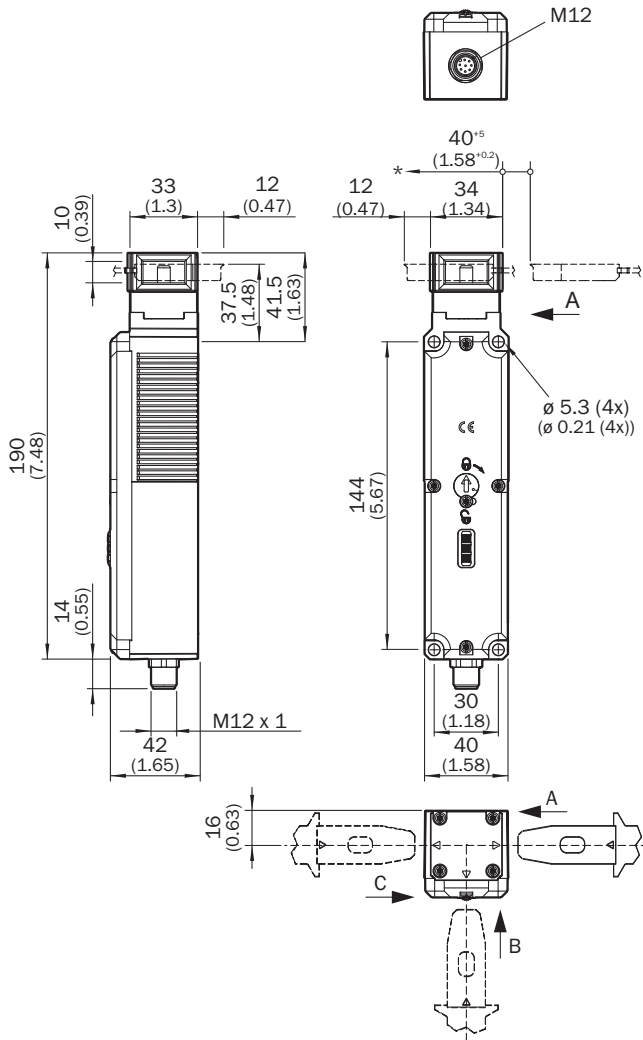

Dimensions in mm (inch)

PIN ASSIGNMENT

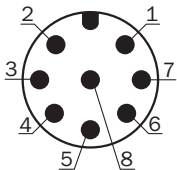

Pin	Designation	Description
1	AUX DOOR	Door application diagnostic output
2	+24 V DC	Safety switch voltage supply
3	Magnet +	Magnet control 24 V DC
4	AUX DIAG	Error application diagnostic output
5	OSSD 1	OSSD 1 output
6	OSSD 2	OSSD 2 output
7	0 V DC / Magnet -	0 V DC voltage supply / magnet control 0 V DC
8	AUX LOCK	Locking application diagnostic output

For details see operating instructions

Further information as well as suitable accessories, example applications and downloads such as CAD dimensional models, operating instructions and software can be found at www.sick.com/6033743



SICK AG
WALDKIRCH
GERMANY
SICK.COM

SICK AT A GLANCE

SICK is a leading global technology company for intelligent sensors and integrated solutions in industrial automation. Our technologies set benchmarks, making your industrial processes more efficient, safer and more sustainable – both in logistics and manufacturing operations.

SICK combines sensor intelligence with industry expertise and certified consulting services. We provide the ideal foundation for scalable as well as tailor-made automation solutions and create added value along the entire value chain. Our close partnerships with our customers are more than just a promise: Together, we optimize productivity, improve quality, protect health and safety, and help build a sustainable future. All with empathy and trust.

Since 1946, we have been developing innovative technologies with passion and a pioneering spirit. With a global network in around 40 countries, SICK has a global presence and is always close by. The company's headquarters are located in Waldkirch near Freiburg, Germany. Our customers benefit from our understanding of both local and global requirements, which enables us to deliver tailor-made solutions

SICK
Sensor Intelligence