



WLL190T-2P434

WLL190

FIBER-OPTIC SENSORS

SICK
Sensor Intelligence.



Illustration may differ



Ordering information

Type	part no.
WLL190T-2P434	6032553

Other models and accessories → www.sick.com/WLL190

Detailed technical data

Features

Device type	Fiber-optic amplifier
Device type detail	Stand-alone
Dimensions (W x H x D)	10.5 mm x 34.8 mm x 76.5 mm
Housing design (light emission)	Rectangular
Sensing range max.	0 m ... 4 m (Through-beam system) ^{1) 2)}
Sensing range	0 mm ... 480 mm, Proximity system ^{3) 4)} 0 m ... 2 m, Through-beam system ⁵⁾
Focus	Approx. 65° ⁶⁾
Type of light	Visible red light
Light source	LED ⁷⁾
Angle of dispersion	Approx. 65° ⁶⁾
Wave length	650 nm
Adjustment	Menu-controlled Single teach-in button Cable
Indication	Display
Display	LED status display / 2x 4-character digital dual displays, Set value (green indicator) and actual value (red indicator) are displayed simultaneously, display of parameters

¹⁾ Sensing range at response time 2 ms. Reduction at shorter response time (see LL3/ WLL190T-2 table).

²⁾ LL3-TB01 and LL3-TA01 tip adaptor.

³⁾ Object with 90% remission (based on standard white DIN 5033). Sensing range at 2 ms response time. Reduced at shorter response times (see LL3 / WLL190T-2 tables).

⁴⁾ LL3-DB01.

⁵⁾ LL3-TB01.

⁶⁾ See LL3 fiber-optic data.

⁷⁾ Average service life: 100,000 h at T_J = +25 °C.

Mechanics/electronics

Supply voltage U_B	10 V DC ... 24 V DC ¹⁾
Ripple	$\leq 10\%$ ²⁾
Current consumption	50 mA
Switching output	PNP ^{3) 4)}
Switching mode	Light/dark switching ^{3) 4)}
Switching mode selector	Manually selectable
Response time	$\leq 2\text{ ms}$, $\leq 60\text{ }\mu\text{s}$, $\leq 250\text{ }\mu\text{s}$
Switching frequency	8,333 Hz, 2,000 Hz, 250 Hz
Time functions	Without time delay Off delay Switch-on delay One shot
Delay time	Programmable, 0 ms ... 9,999 ms
Connection type	Male connector M8, 4-pin
Circuit protection	A ⁵⁾ B ⁶⁾ C ⁷⁾ D ⁸⁾
Protection class	III
Weight	25 g
Housing material	Plastic, ABS/PC
Enclosure rating	IP66 ⁹⁾
Ambient operating temperature	$-25\text{ }^\circ\text{C}$... $+55\text{ }^\circ\text{C}$ ¹⁰⁾
Ambient temperature, storage	$-40\text{ }^\circ\text{C}$... $+70\text{ }^\circ\text{C}$

1) $\pm 10\%$.

2) May not fall below or exceed U_V tolerances.

3) Q₁, Q₂.

4) Selectable Q₂, external teach or counter reset.

5) A = V_S connections reverse-polarity protected.

6) B = inputs and output reverse-polarity protected.

7) C = interference suppression.

8) D = outputs overcurrent and short-circuit protected.

9) With correctly attached fibre-optic cable LL3 and closed protection hood.

10) Operating temperature fluctuates according to number of devices connected: 4–8 devices: $-25\text{ }^\circ\text{C}$... $+50\text{ }^\circ\text{C}$ (output current 50 mA) / 9–16 devices: $-25\text{ }^\circ\text{C}$... $+45\text{ }^\circ\text{C}$ (output current 20 mA).

Safety-related parameters

MTTF_D	290 years
DC_{avg}	0 %

Certificates

EU declaration of conformity	✓
UK declaration of conformity	✓
ACMA declaration of conformity	✓
Moroccan declaration of conformity	✓
China RoHS	✓

Photobiological safety (DIN EN 62471) certificate	✓
--	---

Classifications

ECLASS 5.0	27270905
ECLASS 5.1.4	27270905
ECLASS 6.0	27270905
ECLASS 6.2	27270905
ECLASS 7.0	27270905
ECLASS 8.0	27270905
ECLASS 8.1	27270905
ECLASS 9.0	27270905
ECLASS 10.0	27270905
ECLASS 11.0	27270905
ECLASS 12.0	27270905
ETIM 5.0	EC002651
ETIM 6.0	EC002651
ETIM 7.0	EC002651
ETIM 8.0	EC002651
UNSPSC 16.0901	39121528

Adjustments

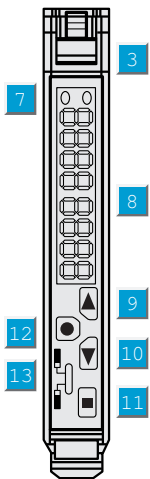

- ③ Locking the fiber-optic cables
- ⑦ Status indicator LED, yellow: Output active
- ⑧ Numeric display 3-digit and 4-digit
- ⑨ step pushbutton > (manual switching threshold: higher/next function parameter)
- ⑩ step pushbutton < (manual switching threshold: lower/previous function parameter)
- ⑪ Teach-in button
- ⑫ Mode/Enter-button
- ⑬ Operating mode selector switch: "SET" (active Teach-in switching threshold) / "RUN" (sensor mode and function parameter selection)

Connection type

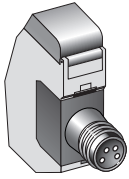

Connection diagram Cd-133

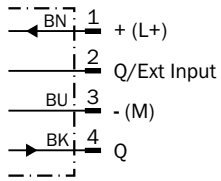

Dimensional drawing

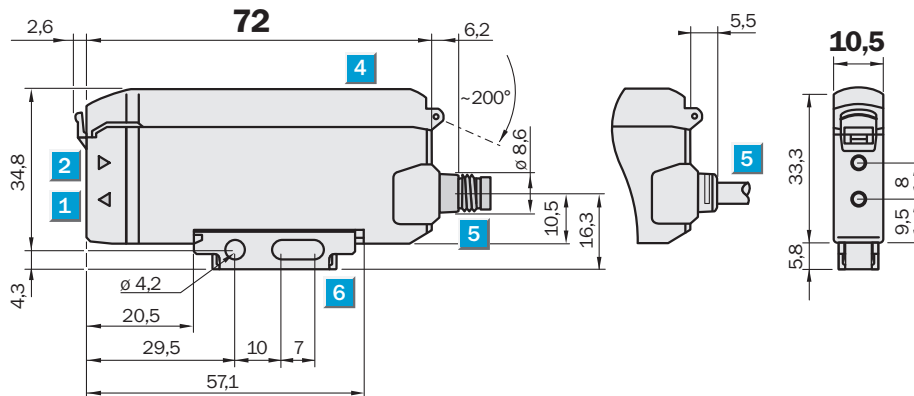



Dimensions in mm (inch)

- ① Sender LED, installation of LL3 fibre-optic cable (sender fibre)
- ② Receiver, installation of LL3 fibre optic cable (receiver fibre)
- ③ Locking the fiber-optic cables
- ④ protective hood opens approx. 180°
- ⑤ Connector M8 or 1-wire cable or 3-wire cable replaceable (cables not included with delivery)
- ⑥ Mounting bracket, included with delivery

Recommended accessories

Other models and accessories → www.sick.com/WLL190

	Brief description	Type	part no.
Mounting systems			
	<ul style="list-style-type: none"> Description: Mounting bracket Material: Steel Details: Steel, zinc coated Items supplied: Without mounting hardware Suitable for: WLL170-2, WLL190-2 	BEF-WLL170	5306574
	<ul style="list-style-type: none"> Description: Rail end piece for block mounting Material: Stainless steel Details: Stainless steel Items supplied: Mounting hardware included 	BEF-EB01-W190	5313011

	Brief description	Type	part no.
connectors and cables			
	<ul style="list-style-type: none"> Description: Unshielded Connection type head A: Female connector, M8, 4-pin, straight, A-coded Connection systems: Screw-type terminals Permitted cross-section: 0.14 mm² ... 0.5 mm² 	DOS-0804-G	6009974
	<ul style="list-style-type: none"> Description: Unshielded Connection type head A: Female connector, M8, 4-pin, angled, A-coded Connection systems: Solder connection Permitted cross-section: ≤ 0.25 mm² 	DOS-0804-W	6009975
	<ul style="list-style-type: none"> Description: Unshielded Connection type head A: Male connector, M8, 4-pin, straight, A-coded Connection systems: Screw-type terminals Permitted cross-section: 0.14 mm² ... 0.5 mm² 	STE-0804-G	6037323
	<ul style="list-style-type: none"> Connection type head A: Female connector, M8, 4-pin, straight, A-coded Connection type head B: Flying leads Signal type: Sensor/actuator cable Cable: 2 m, 4-wire, PVC Description: Sensor/actuator cable, unshielded Application: Uncontaminated zones, Zones with chemicals 	YF8U14-020VA3XLEAX	2095888
	<ul style="list-style-type: none"> Connection type head A: Female connector, M8, 4-pin, straight, A-coded Connection type head B: Flying leads Signal type: Sensor/actuator cable Cable: 5 m, 4-wire, PVC Description: Sensor/actuator cable, unshielded Application: Uncontaminated zones, Zones with chemicals 	YF8U14-050VA3XLEAX	2095889
	<ul style="list-style-type: none"> Connection type head A: Female connector, M8, 4-pin, angled, A-coded Connection type head B: Flying leads Signal type: Sensor/actuator cable Cable: 2 m, 4-wire, PVC Description: Sensor/actuator cable, unshielded Application: Uncontaminated zones, Zones with chemicals 	YG8U14-020VA3XLEAX	2095962
	<ul style="list-style-type: none"> Connection type head A: Female connector, M8, 4-pin, angled, A-coded Connection type head B: Flying leads Signal type: Sensor/actuator cable Cable: 5 m, 4-wire, PVC Description: Sensor/actuator cable, unshielded Application: Uncontaminated zones, Zones with chemicals 	YG8U14-050VA3XLEAX	2095963
	<ul style="list-style-type: none"> Connection type head A: Female connector, M8, 4-pin, straight, A-coded Connection type head B: Flying leads Signal type: Sensor/actuator cable Cable: 0.6 m, 4-wire, PVC Description: Sensor/actuator cable, unshielded Application: Uncontaminated zones, Zones with chemicals 	YF8U14-C60VA3XLEAX	2145852
	<ul style="list-style-type: none"> Connection type head A: Female connector, M8, 4-pin, straight, A-coded Connection type head B: Flying leads Signal type: Sensor/actuator cable Cable: 1 m, 4-wire, PVC Description: Sensor/actuator cable, unshielded Application: Uncontaminated zones, Zones with chemicals 	YF8U14-010VA3XLEAX	2145853
	<ul style="list-style-type: none"> Connection type head A: Female connector, M8, 4-pin, angled, A-coded Connection type head B: Flying leads Signal type: Sensor/actuator cable Cable: 0.6 m, 4-wire, PVC Description: Sensor/actuator cable, unshielded Application: Uncontaminated zones, Zones with chemicals 	YG8U14-C60VA3XLEAX	2145854
	<ul style="list-style-type: none"> Connection type head A: Female connector, M8, 4-pin, angled, A-coded Connection type head B: Flying leads Signal type: Sensor/actuator cable Cable: 3 m, 4-wire, PVC Description: Sensor/actuator cable, unshielded 	YG8U14-030VA3XLEAX	2145857

	Brief description	Type	part no.
	<ul style="list-style-type: none">• Application: Untaminated zones, Zones with chemicals• Connection type head A: Female connector, M8, 4-pin, angled, A-coded• Connection type head B: Flying leads• Signal type: Sensor/actuator cable• Cable: 1 m, 4-wire, PVC• Description: Sensor/actuator cable, unshielded• Application: Untaminated zones, Zones with chemicals	YG8U14-010VA3XLEAX	2145855

SICK AT A GLANCE

SICK is one of the leading manufacturers of intelligent sensors and sensor solutions for industrial applications. A unique range of products and services creates the perfect basis for controlling processes securely and efficiently, protecting individuals from accidents and preventing damage to the environment.

We have extensive experience in a wide range of industries and understand their processes and requirements. With intelligent sensors, we can deliver exactly what our customers need. In application centers in Europe, Asia and North America, system solutions are tested and optimized in accordance with customer specifications. All this makes us a reliable supplier and development partner.

Comprehensive services complete our offering: SICK LifeTime Services provide support throughout the machine life cycle and ensure safety and productivity.

For us, that is “Sensor Intelligence.”

WORLDWIDE PRESENCE:

Contacts and other locations –www.sick.com