



TR4-RBM00B

Actuators for RFID safety switches

ACTUATORS

SICK
Sensor Intelligence.



Ordering information

Type	part no.
TR4-RBM00B	5339105

Other models and accessories → www.sick.com/Actuators_for_RFID_safety_switches



Detailed technical data

Features

Product segment	Actuators and bolts
Product	Actuators for RFID safety switches
Description	Replacement actuator, M30, for R4-SBMxxxB
Suitable for	TR4-SBMxxxB
Design	Cylindrical

Classifications

ECLASS 5.0	27270691
ECLASS 5.1.4	27270605
ECLASS 6.0	27270605
ECLASS 6.2	27270605
ECLASS 7.0	27270605
ECLASS 8.0	27270605
ECLASS 8.1	27270605
ECLASS 9.0	27270605
ECLASS 10.0	27270605
ECLASS 11.0	27270605
ECLASS 12.0	27270612
ETIM 5.0	EC001487
ETIM 6.0	EC001487
ETIM 7.0	EC001487
ETIM 8.0	EC001487

Certificates

EU declaration of conformity	✓
UK declaration of conformity	✓
ACMA declaration of conformity	✓
China RoHS	✓

cULus certificate	✓
EC-Type-Examination approval	✓

Dimensional drawing

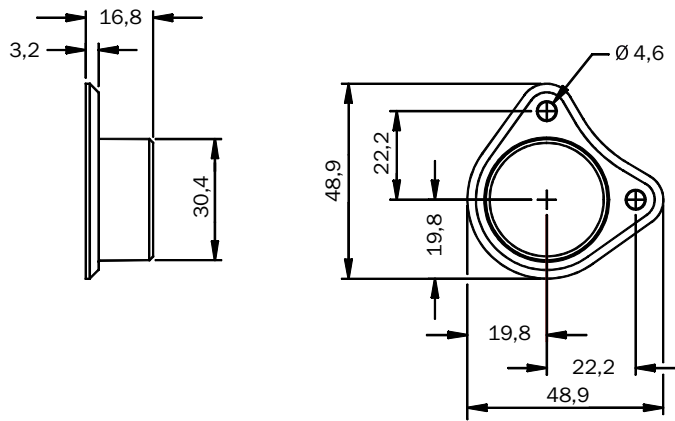

Dimensions in mm (inch)

SICK AT A GLANCE

SICK is one of the leading manufacturers of intelligent sensors and sensor solutions for industrial applications. A unique range of products and services creates the perfect basis for controlling processes securely and efficiently, protecting individuals from accidents and preventing damage to the environment.

We have extensive experience in a wide range of industries and understand their processes and requirements. With intelligent sensors, we can deliver exactly what our customers need. In application centers in Europe, Asia and North America, system solutions are tested and optimized in accordance with customer specifications. All this makes us a reliable supplier and development partner.

Comprehensive services complete our offering: SICK LifeTime Services provide support throughout the machine life cycle and ensure safety and productivity.

For us, that is “Sensor Intelligence.”

WORLDWIDE PRESENCE:

Contacts and other locations –www.sick.com