



ES21-AT1140

ES21

SAFETY COMMAND DEVICES

SICK
Sensor Intelligence.



Ordering information

Type	part no.
ES21-AT1140	5321165

Other models and accessories → www.sick.com/ES21



Detailed technical data

Features

Actuation directions	1
Obstruction protection	✓
Release type	Rotary release
Protective collar	✓

Functions

Safe series connection	None, only individual wiring (with diagnostics)
-------------------------------	---

Electronics - Operating data

Switching principle	Slow action switching element
----------------------------	-------------------------------

Mechanics

Dimensions	67 mm x 61 mm
Mounting diameter	22 mm
Weight	80 g
Housing material	Plastic
Mechanical life	50.000 switching cycles

Ambient data

Enclosure rating	IP65 (IEC 60529)
Ambient operating temperature	-30 °C ... +70 °C
Storage temperature	-50 °C ... +85 °C

Classifications

ECLASS 5.0	27371228
ECLASS 5.1.4	27371228
ECLASS 6.0	27371244
ECLASS 6.2	27371244
ECLASS 7.0	27371244

ECLASS 8.0	27371244
ECLASS 8.1	27371244
ECLASS 9.0	27371244
ECLASS 10.0	27371291
ECLASS 11.0	27371291
ECLASS 12.0	27371291
ETIM 5.0	EC002034
ETIM 6.0	EC002034
ETIM 7.0	EC002034
ETIM 8.0	EC002034
UNSPSC 16.0901	39121545

Certificates

EU declaration of conformity	✓
UK declaration of conformity	✓
cULus certificate	✓
Third party certificate	✓

Dimensional drawing

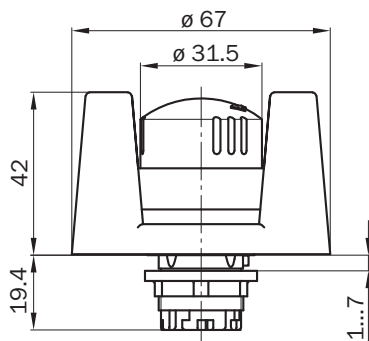

Dimensions in mm (inch)

SICK AT A GLANCE

SICK is one of the leading manufacturers of intelligent sensors and sensor solutions for industrial applications. A unique range of products and services creates the perfect basis for controlling processes securely and efficiently, protecting individuals from accidents and preventing damage to the environment.

We have extensive experience in a wide range of industries and understand their processes and requirements. With intelligent sensors, we can deliver exactly what our customers need. In application centers in Europe, Asia and North America, system solutions are tested and optimized in accordance with customer specifications. All this makes us a reliable supplier and development partner.

Comprehensive services complete our offering: SICK LifeTime Services provide support throughout the machine life cycle and ensure safety and productivity.

For us, that is “Sensor Intelligence.”

WORLDWIDE PRESENCE:

Contacts and other locations –www.sick.com