



Mounting bracket kit 0° - 55°

Brackets

MOUNTING SYSTEMS

SICK
Sensor Intelligence.



Ordering information

Type	part no.
Mounting bracket kit 0° - 55°	2131254

Other models and accessories → www.sick.com/Brackets

Detailed technical data

Features

Accessory group	Mounting systems
Accessory family	Brackets
Description	Mounting bracket kit for Lector85x (system) 0° - 55°
Suitable for	Lector85x, Lector85x system, Lector65x, Inspector85x, Lector85x, Lector85x system, Lector65x, Inspector85x, Lector85x, Lector85x system, Lector65x, Inspector85x, Lector85x, Lector85x system, Lector65x
Color	Silver
Items supplied	Mounting bracket including mounting kit (screws, washers, sliding nuts for mounting to aluminum profile system (compatible with ITEM slot-8))
Dimensions (W x H x L)	20 cm x 20 cm x 5 cm
Weight	634 g
Mounting system type	Brackets

Classifications

ECLASS 12.0	27273701
--------------------	----------

Dimensional drawing

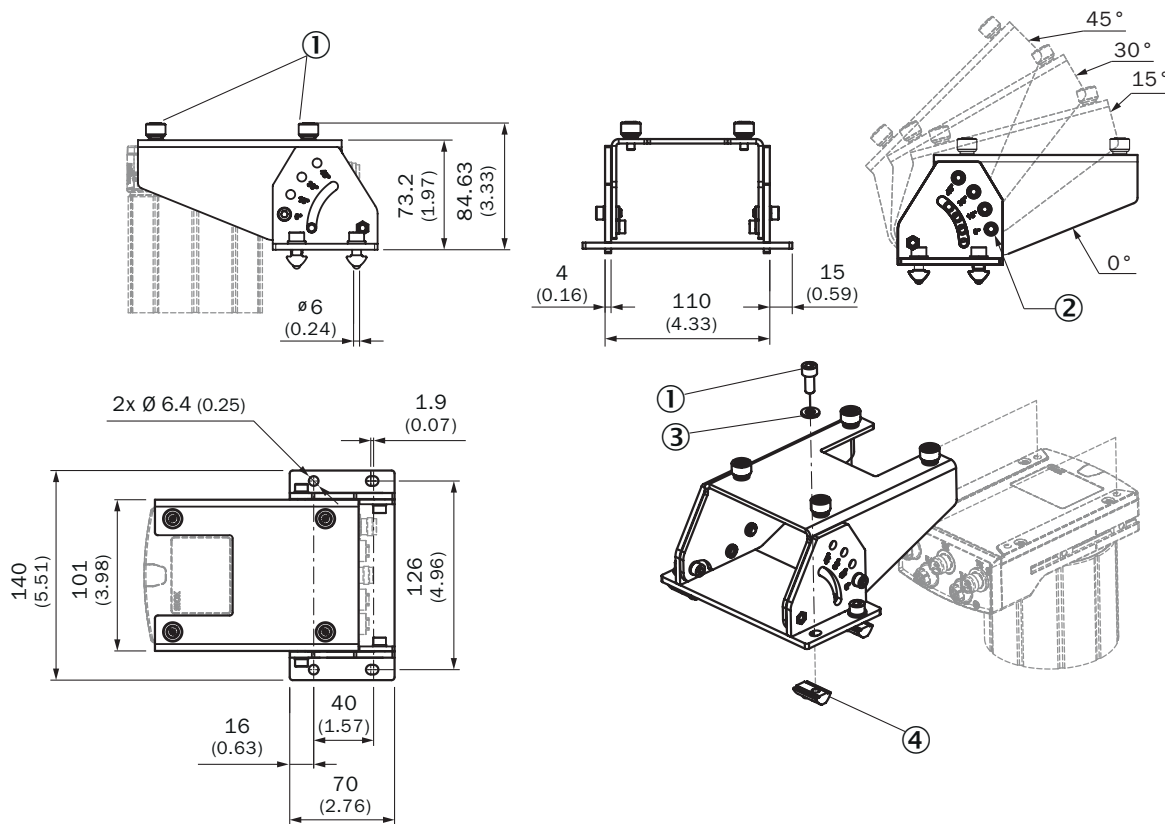

Dimensions in mm (inch)

Structure and dimensions of mounting bracket set 2131254, unit of measurement: mm (inch), decimal separator: point

- ① 4x M6 screws, 14 mm long, for attaching the mounting bracket to the product, tighten by hand
- ② Angle adjustment
- ③ 4 washers
- ④ 4x M6 sliding nuts, diameter: 6 mm

SICK AT A GLANCE

SICK is one of the leading manufacturers of intelligent sensors and sensor solutions for industrial applications. A unique range of products and services creates the perfect basis for controlling processes securely and efficiently, protecting individuals from accidents and preventing damage to the environment.

We have extensive experience in a wide range of industries and understand their processes and requirements. With intelligent sensors, we can deliver exactly what our customers need. In application centers in Europe, Asia and North America, system solutions are tested and optimized in accordance with customer specifications. All this makes us a reliable supplier and development partner.

Comprehensive services complete our offering: SICK LifeTime Services provide support throughout the machine life cycle and ensure safety and productivity.

For us, that is “Sensor Intelligence.”

WORLDWIDE PRESENCE:

Contacts and other locations –www.sick.com