



DATA SHEET

C4000 Standard adapter kit for de- Tec4 RES

Brackets
Mounting systems

SICK Sensor Intelligence

MOUNTING SYSTEMS

C4000 Standard adapter kit for de-Tec4 RES

ORDERING INFORMATION

Type	part no.
C4000 Standard adapter kit for deTec4 RES	2075992

Further device versions and accessories at www.sick.com/Brackets

DETAILED TECHNICAL DATA

FEATURES

Accessory group	Mounting systems
Accessory family	Brackets
Description	Adapter kit for easy exchange of C4000 Standard with deTec4 with system plug 2076834 (functional scope SP1; system connection M12, 8-pin; without extension connection).
Items supplied	All electrical and mechanical adapters for exchanging sender and receiver (4 brackets and 2 cables).
Specialty	The "application diagnostic output (ADO)" signal is not transmitted, see pin assignment graphic.
Mounting system type	Adaptor

PIN ASSIGNMENT

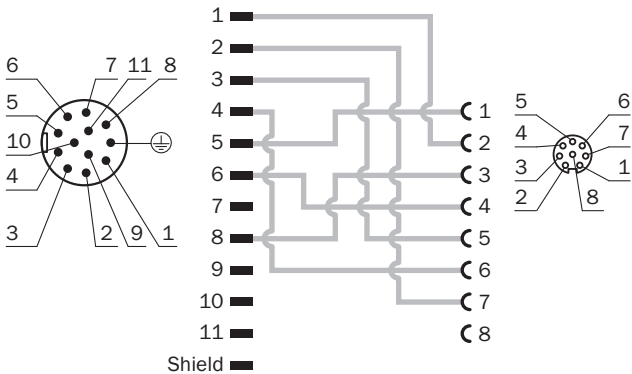

Further information as well as suitable accessories, example applications and downloads such as CAD dimensional models, operating instructions and software can be found at www.sick.com/2075992



SICK AG
WALDKIRCH
GERMANY
SICK.COM

SICK AT A GLANCE

SICK is a leading global technology company for intelligent sensors and integrated solutions in industrial automation. Our technologies set benchmarks, making your industrial processes more efficient, safer and more sustainable – both in logistics and manufacturing operations.

SICK combines sensor intelligence with industry expertise and certified consulting services. We provide the ideal foundation for scalable as well as tailor-made automation solutions and create added value along the entire value chain. Our close partnerships with our customers are more than just a promise: Together, we optimize productivity, improve quality, protect health and safety, and help build a sustainable future. All with empathy and trust.

Since 1946, we have been developing innovative technologies with passion and a pioneering spirit. With a global network in around 40 countries, SICK has a global presence and is always close by. The company's headquarters are located in Waldkirch near Freiburg, Germany. Our customers benefit from our understanding of both local and global requirements, which enables us to deliver tailor-made solutions

SICK
Sensor Intelligence