



DATA SHEET

MLG10S-0590D10801

MLG-2
Automation light grids

SICK Sensor Intelligence

AUTOMATION LIGHT GRIDS

ML- G10S-0590D10801

ORDERING INFORMATION

Type	part no.
MLG10S-0590D10801	1219711

Further device versions and accessories at www.sick.com/MLG-2



Illustration may differ

DETAILED TECHNICAL DATA

FEATURES

Device version	Prime - Standard functionality	
Sensor principle	Sender/receiver	
Minimum detectable object (MDO)	14 mm ¹⁾	
Beam separation	10 mm	
Type of synchronization	Optical	
Number of beams	60	
Detection height	590 mm	
Software features (default)	Q ₁	Auto-define height classification
	Q ₂ / IN	Auto-define height classification
	Q ₃	Auto-define height classification
	inverted	—
	Teach	—
	key lock	off
Operating mode	Standard	✓
Function	Cross beam	✓
	Beam blanking	✓
Applications	Switching output	Object detection Object recognition Height classification

¹⁾ Depending on beam separation without cross beam setting.

Data interface	Object detection Object height measurement
Included with delivery	1 × sender 1 × receiver 4/6 × QuickFix brackets (6 × QuickFix brackets for monitoring heights above 2 m) 1 × Quick Start Guide

¹⁾ Depending on beam separation without cross beam setting.

MECHANICS/ELECTRONICS

Light source	LED, Infrared light
Wave length	850 nm
Supply voltage V_s	DC 19.2 V ... 28.8 V ¹⁾
Power consumption sender	58 mA ²⁾
Power consumption receiver	132 mA ²⁾
Ripple	< 5 V _{pp}
Output current I_{max}	100 mA
Output load, capacitive	100 nF
Output load, Inductive	1 H
Initialization time	< 1 s
Switching output	Push-pull: PNP/NPN
Connection type	Plug, M12, 5-pin, 0.22 m
Housing material	Aluminum
Display	LED
Enclosure rating	IP65, IP67 ³⁾
Circuit protection	U_v connections, reverse polarity protected Output Q short-circuit protected Interference pulse suppression
Protection class	III
Weight	1.449 kg
Front screen	PMMA
Option	None
UL File No.	NRKH.E181493

¹⁾ Without load.

²⁾ Without load with 24 V.

³⁾ Operating in outdoor condition only with a external protection housing.

PERFORMANCE

Maximum range	12 m ¹⁾
Minimum range	≥ 0.5 m
Operating range	8.5 m
Response time	8.2 ms

¹⁾ No reserve for environmental issue and deterioration of the diode.

INTERFACES

IO-Link	✓, IO-Link V1.1
Data transmission rate	38,4 kbit/s (COM2)
Maximum cable length	20 m
Cycle time	6 ms
VendorID	26
DeviceID HEX	800067
DeviceID DEC	8388711
Process data length	6 Byte (TYPE_2_V) ¹⁾
Inputs/outputs	3 x Q (IO-Link)
Digital output	Q ₁ ... Q ₃
Number	3
Digital input	In ₁
Number	1

¹⁾ For an IO-Link master with V1.0, reverts to interleaved mode (consisting of TYPE_1_1 (ProcessData) and TYPE_1_2 (on-request data)).

AMBIENT DATA

Shock resistance	Continuous shocks 10 g, 16 ms, 1000 shocks Single shocks 15 g, 11 ms 3 per axle
Vibration resistance	Sinusoidal oscillation 10-150 Hz 5 g
EMC	EN 60947-5-2
Ambient light immunity	Direct: 12,000 lx ¹⁾ Indirect: 50,000 lx ²⁾
Ambient operating temperature	-30 °C ... +55 °C
Ambient temperature, storage	-40 °C ... +70 °C

¹⁾ Outdoor mode.

²⁾ Light resistance indirect.

SMART TASK

Smart Task name	Base logics
-----------------	-------------

CERTIFICATES

EU declaration of conformity	✓
UK declaration of conformity	✓
ACMA declaration of conformity	✓
Moroccan declaration of conformity	✓
cULus certificate	✓
IO-Link certificate	✓
Photobiological safety (IEC EN 62471)	✓

DIMENSIONAL DRAWING

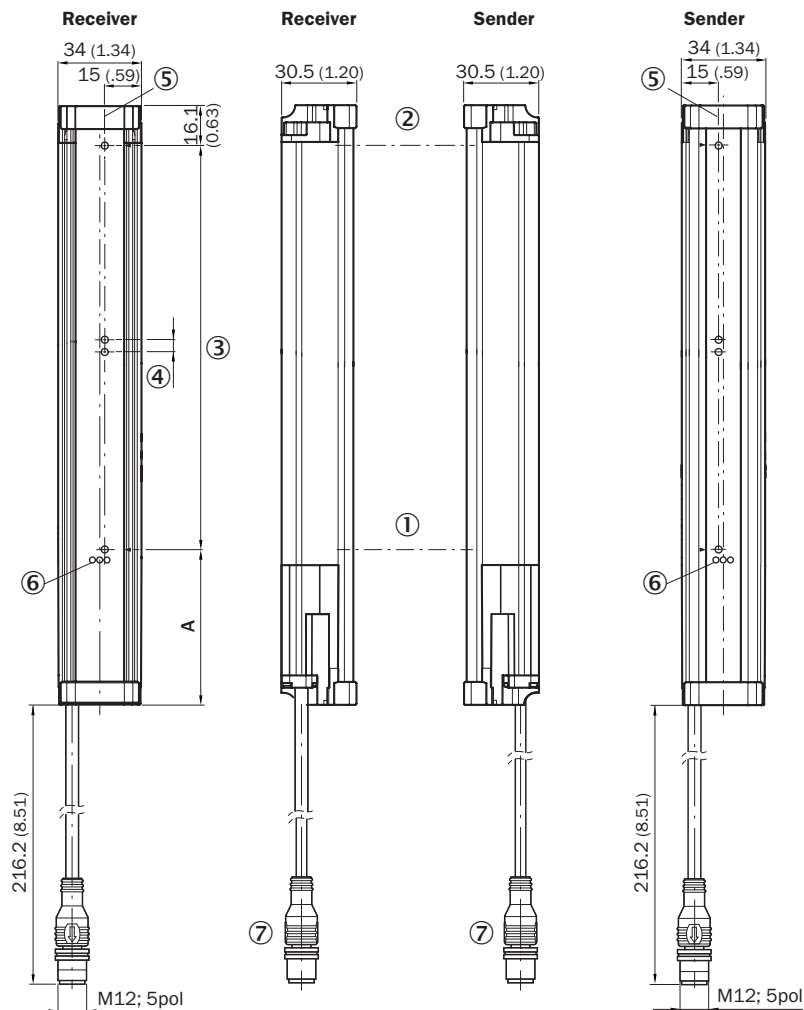

A¹⁾

Beam separation 5 mm	63.3 (2.49)
Beam separation 10 mm	68.3 (2.69)
Beam separation 20 mm	68.3 (2.69)/78.3 (3.08) ⁽²⁾
Beam separation 25 mm	83.3 (3.28)
Beam separation 30 mm	88.3 (3.48)
Beam separation 50 mm	108.3 (4.26)

¹⁾ Distance: MLG edge - first beam

²⁾ MLG20x-xx**40**: 68.3 mm
MLG20x-xx**80**: 78.3 mm

Dimensions in mm (inch)

- ① First beam
- ② last beam
- ③ detection height (see technical data)
- ④ Beam separation
- ⑤ Optical axis
- ⑥ status indicator: green, yellow, red LEDs
- ⑦ Connection

CONNECTION TYPE AND DIAGRAM CONNECTOR M12, 5-PIN, SWITCHING OUTPUTS Q

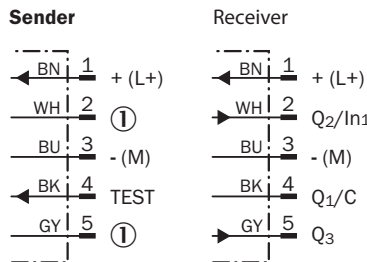

① Not assigned

ADJUSTMENTS



- ① MLG-2 with switching outputs Q
- ② MLG-2 with analog outputs Q_A
- ③ status indicator: green, yellow, red LEDs

FUNCTIONAL PRINCIPLE OPTICAL SYNCHRONIZATION

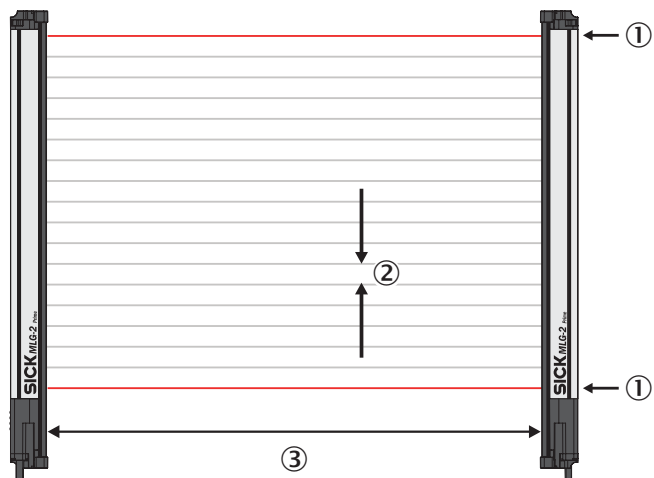

The sender and receiver synchronize with each other optically, so no electrical connection is necessary. For this reason, either the first or the last beam of the automation light grid must remain clear. If both beams are interrupted, no measurements can be taken.

- ① Optical synchronization
- ② Beam separation
- ③ scanning range

Further information as well as suitable accessories, example applications and downloads such as CAD dimensional models, operating instructions and software can be found at www.sick.com/1219711



SICK AG
WALDKIRCH
GERMANY
SICK.COM

SICK AT A GLANCE

SICK is a leading global technology company for intelligent sensors and integrated solutions in industrial automation. Our technologies set benchmarks, making your industrial processes more efficient, safer and more sustainable – both in logistics and manufacturing operations.

SICK combines sensor intelligence with industry expertise and certified consulting services. We provide the ideal foundation for scalable as well as tailor-made automation solutions and create added value along the entire value chain. Our close partnerships with our customers are more than just a promise: Together, we optimize productivity, improve quality, protect health and safety, and help build a sustainable future. All with empathy and trust.

Since 1946, we have been developing innovative technologies with passion and a pioneering spirit. With a global network in around 40 countries, SICK has a global presence and is always close by. The company's headquarters are located in Waldkirch near Freiburg, Germany. Our customers benefit from our understanding of both local and global requirements, which enables us to deliver tailor-made solutions

SICK
Sensor Intelligence