



WTM12F-1H161120A00ZDZZZZZZZZZZ1
W12

PHOTOELECTRIC SENSORS

SICK
Sensor Intelligence.



Illustration may differ

Ordering information

Type	part no.
WTM12F-1H161120A00ZDZZZZZZZZ1	1152368

Other models and accessories → www.sick.com/W12



Detailed technical data

Features

Functional principle	Photoelectric proximity sensor
Functional principle detail	Background suppression, Foreground suppression, MultiMode, distance value
MultiMode	1 Background suppression 2 Foreground suppression 3 Two Value Teach-in 4 Two independent switching points 5 Window Mode 6 ApplicationSelect M manual / measurement
Sensing range	
Sensing range min.	10 mm (mode 1, 3, 4, 5) 0 mm (mode 2)
	10 mm (Mode 1, 3, 4, 5 combined with 6) 0 mm (Mode 2 and 6 combined)
Sensing range max.	1,100 mm (mode 1, 3, 4, 5) 650 mm (mode 2)
	1,400 mm (Mode 1, 3, 4, 5 combined with 6) 1,000 mm (Mode 2 and 6 combined)

- ¹⁾ 90% remission factor.
- ²⁾ Equivalent to 3 σ .
- ³⁾ See repeatability characteristic lines.
- ⁴⁾ See accuracy curve.

Adjustable switching threshold for background suppression	40 mm ... 1,100 mm (mode 1, 3, 4, 5)
	40 mm ... 1,400 mm (Mode 1, 3, 4, 5 combined with 6)
Adjustable switching threshold for foreground suppression	40 mm ... 650 mm (mode 2)
	40 mm ... 1,000 mm (Mode 2 and 6 combined)
Reference object	Object with 90% remission factor (complies with standard white according to DIN 5033)
Minimum distance between set sensing range and background (black 6% / white 90%)	9 mm, at a distance of 400 mm (mode 1, 3, 4, 5)
	3 mm, at a distance of 400 mm (Mode 1, 3, 4, 5 combined with 6)
Minimum object height at set sensing range in front of black background (6% remission factor)	9 mm, at a distance of 400 mm (mode 2)
	3 mm, at a distance of 400 mm (Mode 2 and 6 combined)
Recommended sensing range for the best performance	50 mm ... 550 mm
Distance value	
Measuring range	40 mm ... 1,000 mm
Resolution	1 mm
Repeatability	0,2 mm ... 9 mm ^{1) 2) 3)}
Accuracy	Typ. 12 mm at a distance of 40 ... 600 mm ^{1) 4)}
Distance value output	Via IO-Link
Update rate of the distance value	8 ms
Emitted beam	
Light source	PinPoint Pro LED
Type of light	Visible red light
Shape of light spot	Rectangular
Light spot size (distance)	14 mm x 11 mm (400 mm)
Maximum dispersion of the emitted beam around the standardized transmission axis (squint angle)	< +/- 1.0° (at T _U = +23 °C)
Focus position	600 mm
Key LED figures	
Normative reference	EN 62471:2008-09 IEC 62471:2006, modified
LED risk group marking	Free group
Wave length	635 nm
Average service life	100,000 h at T _a = +25 °C
Smallest detectable object (MDO) typ.	
	0.3 mm, at a distance of 200 mm, mode 1, 3, 4, 5
	0.3 mm, at a distance of 200 mm, mode 2
	0.3 mm, at a distance of 200 mm, Mode 1, 3, 4, 5 combined with 6
	0.3 mm, at a distance of 200 mm, Mode 2 and 6 combined

1) 90% remission factor.

2) Equivalent to 3 σ.

3) See repeatability characteristic lines.

4) See accuracy curve.

		Object with 90% remission factor (complies with standard white according to DIN 5033)
Adjustment	Teach-Turn adjustment	BluePilot For adjusting the sensing range with mode selection
	IO-Link	For configuring the sensor parameters and Smart Task functions
Display	LED blue	BluePilot: Display of mode, display of output states Q _{L1} (LED 3 permanently on) and Q _{L2} (LED 5 permanently on)
	LED green	Operating indicator Static on: power on Flashing: IO-Link mode
	LED yellow	Status of received light beam Static on: object present Static off: object not present
Special features		MultiMode

¹⁾ 90% remission factor.

²⁾ Equivalent to 3 σ .

³⁾ See repeatability characteristic lines.

⁴⁾ See accuracy curve.

Safety-related parameters

MTTF_D	1,208 years
DC_{avg}	0 %
T_M (mission time)	20 years

Communication interface

IO-Link		✓ , IO-Link V1.1
Data transmission rate		COM2 (38,4 kBaud)
Cycle time		2.3 ms
Process data length		16 Bit
Process data structure A		Bit 0 = switching signal Q _{L1}
		Bit 1 = switching signal Q _{L2}
		Bit 2 ... 15 = Current receiver level (live)
Process data structure B		Bit 0 ... 15 = Distance value 0.1 mm (live)
VendorID		26
DeviceID HEX		0x8003A4
DeviceID DEC		8389540
Compatible master port type		A
SIO mode support		Yes

Electronics

Supply voltage U_B	10 V DC ... 30 V DC ¹⁾
Ripple	≤ 5 V
Usage category	DC-12 (According to EN 60947-5-2) DC-13 (According to EN 60947-5-2)
Current consumption	≤ 40 mA, without load. At $U_B = 24$ V
Protection class	III
Digital output	
Number	2 (Complementary)
Type	Push-pull: PNP/NPN
Switching mode	Light/dark switching
Signal voltage PNP HIGH/LOW	Approx. $U_B - 2.5$ V / 0 V
Signal voltage NPN HIGH/LOW	Approx. $U_B / < 2.5$ V
Output current I_{max}	≤ 100 mA
Circuit protection outputs	Reverse polarity protected
	Overcurrent protected
	Short-circuit protected
Response time	≤ 330 μs ^{2) 3)}
	≤ 350 μs ^{2) 4)}
	≤ 15 ms ^{2) 5)}
	≤ 30 ms ^{2) 6)}
Repeatability (response time)	100 μs (mode 1, 2, 3) ²⁾
	1,000 μs (mode 4, 5) ²⁾
	5 ms (Mode 1, 2, 3 combined with 6) ²⁾
	10 ms (Mode 4, 5 combined with 6) ²⁾
Switching frequency	1,500 Hz (mode 1, 2, 3) ⁷⁾
	500 Hz (mode 4, 5) ⁷⁾
	30 Hz (Mode 1, 2, 3 combined with 6) ⁷⁾
	15 Hz (Mode 4, 5 combined with 6) ⁷⁾
Pin/Wire assignment	
Function of pin 4/black (BK)	Digital output, light switching, object present → output QL1 HIGH (Mode 1, 3, 4, 5, 6) ⁸⁾
	Digital output, dark switching, object present → output \bar{Q} L1 HIGH (Mode 2) ⁸⁾
	IO-Link communication C
Function of pin 4/black (BK) – detail	The pin 4 function of the sensor can be configured

¹⁾ Limit values.

²⁾ Signal transit time with resistive load in switching mode.

³⁾ Mode 1, 2, 3.

⁴⁾ Mode 4, 5.

⁵⁾ Mode 1, 2, 3 combined with 6.

⁶⁾ Mode 4, 5 combined with 6.

⁷⁾ With light/dark ratio 1:1.

⁸⁾ This switching output must not be connected to another output.

Function of pin 2/white (WH)	Additional possible settings via IO-Link
	Digital output, dark switching, object present → output $\bar{Q}L1$ LOW (Mode 1, 3, 5, 6) ⁸⁾
	Digital output, light switching, object present → output QL1 LOW (Mode 2) ⁸⁾
Function of pin 2/white (WH) – detail	Digital output, light switching, object present → output QL2 HIGH (Mode 4) ⁸⁾
	The pin 2 function of the sensor can be configured
	Additional possible settings via IO-Link

¹⁾ Limit values.

²⁾ Signal transit time with resistive load in switching mode.

³⁾ Mode 1, 2, 3.

⁴⁾ Mode 4, 5.

⁵⁾ Mode 1, 2, 3 combined with 6.

⁶⁾ Mode 4, 5 combined with 6.

⁷⁾ With light/dark ratio 1:1.

⁸⁾ This switching output must not be connected to another output.

Mechanics

Housing	Rectangular
Dimensions (W x H x D)	15.6 mm x 49.5 mm x 43.1 mm
Connection	Cable, 4-wire, 2 m
Connection detail	
Deep-freeze property	Do not bend below 0 °C
Conductor size	0.14 mm ²
Cable diameter	Ø 3.4 mm
Length of cable (L)	2 m
Bending radius	For flexible use > 12 x cable diameter
Bending cycles	1,000,000
Material	
Housing	Metal, zinc diecast
Front screen	Plastic, PMMA
Cable	Plastic, PVC
Weight	Approx. 132 g
Maximum tightening torque of the fixing screws	1.4 Nm

Ambient data

Enclosure rating	IP66 (EN 60529) IP67 (EN 60529) IP69 (EN 60529)
Ambient operating temperature	-40 °C ... +60 °C
Ambient temperature, storage	-40 °C ... +75 °C
Typ. Ambient light immunity	Artificial light: ≤ 50,000 lx Sunlight: ≤ 50,000 lx
Shock resistance	50 g, 11 ms (25 positive and 25 negative shocks along X, Y, Z axes, 150 total shocks (EN60068-2-27))
Vibration resistance	10 Hz ... 2,000 Hz (Amplitude 0.5 mm / 10 g, 20 sweeps per axis, for X, Y, Z axes, 1 octave/min, (EN60068-2-6))
Air humidity	35 % ... 95 %, relative humidity (no condensation)

Electromagnetic compatibility (EMC)	EN 60947-5-2
Resistance to cleaning agent	ECOLAB
UL File No.	NRKH.E181493 & NRKH7.E181493

Smart Task

Smart Task name	Base logics
Logic function	Direct AND OR
Timer function	Deactivated Switch-on delay Off delay ON and OFF delay Impulse (one shot)
Inverter	Yes
Switching frequency	SIO Logic: 1300 Hz (mode 1, 2, 3) ¹⁾ SIO Logic: 450 Hz (mode 4, 5) ¹⁾ SIO Logic: 30 Hz (Mode 1, 2, 3 combined with 6) ¹⁾ SIO Logic: 15 Hz (Mode 4, 5 combined with 6) ¹⁾ IOL: 1200 Hz (mode 1, 2, 3) ²⁾ IOL: 450 Hz (mode 4, 5) ²⁾ IOL: 30 Hz (Mode 1, 2, 3 combined with 6) ²⁾ IOL: 15 Hz (Mode 4, 5 combined with 6) ²⁾
Response time	SIO Logic: 390 µs (mode 1, 2, 3) ¹⁾ SIO Logic: 400 µs (mode 4, 5) ¹⁾ SIO Logic: 15 ms (Mode 1, 2, 3 combined with 6) ¹⁾ SIO Logic: 30 ms (Mode 4, 5 combined with 6) ¹⁾ IOL: 420 µs (mode 1, 2, 3) ²⁾ IOL: 450 µs (mode 4, 5) ²⁾ IOL: 15 ms (Mode 1, 2, 3 combined with 6) ²⁾ IOL: 30 ms (Mode 4, 5 combined with 6) ²⁾
Repeatability	SIO Logic: 140 µs (mode 1, 2, 3) ¹⁾ SIO Logic: 1100 µs (mode 4, 5) ¹⁾ SIO Logic: 5 ms (Mode 1, 2, 3 combined with 6) ¹⁾ SIO Logic: 10 ms (Mode 4, 5 combined with 6) ¹⁾ IOL: 170 µs (mode 1, 2, 3) ²⁾ IOL: 1100 µs (mode 4, 5) ²⁾ IOL: 5 ms (Mode 1, 2, 3 combined with 6) ²⁾ IOL: 10 ms (Mode 4, 5 combined with 6) ²⁾
Switching signal	
Switching signal Q _{L1}	Switching output
Switching signal \bar{Q} _{L1}	Switching output

¹⁾ Use of Smart Task functions without IO-Link communication (SIO mode).

²⁾ Use of Smart Task functions with IO-Link communication function.

Diagnosis

Device temperature	
Measuring range	Very cold, cold, moderate, warm, hot
Device status	Yes
Detailed device status	Yes

Operating hour counter	Yes
Operating hours counter with reset function	Yes
Quality of teach	Yes
Quality of run	Yes, Contamination display

Certificates

EU declaration of conformity	✓
UK declaration of conformity	✓
ACMA declaration of conformity	✓
Moroccan declaration of conformity	✓
China RoHS	✓
ECOLAB certificate	✓
cULus certificate	✓
IO-Link certificate	✓
Photobiological safety (IEC EN 62471)	✓
Information according to Art. 3 of Data Act (Regulation EU 2023/2854)	✓

Classifications

ECLASS 5.0	27270904
ECLASS 5.1.4	27270904
ECLASS 6.0	27270904
ECLASS 6.2	27270904
ECLASS 7.0	27270904
ECLASS 8.0	27270904
ECLASS 8.1	27270904
ECLASS 9.0	27270904
ECLASS 10.0	27270904
ECLASS 11.0	27270904
ECLASS 12.0	27270903
ETIM 5.0	EC002719
ETIM 6.0	EC002719
ETIM 7.0	EC002719
ETIM 8.0	EC002719
UNSPSC 16.0901	39121528

display and adjustment elements

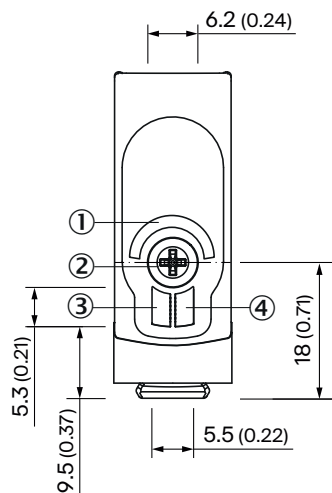

- ① LED blue
- ② Teach-Turn adjustment
- ③ LED green
- ④ LED yellow

Display and setting detail

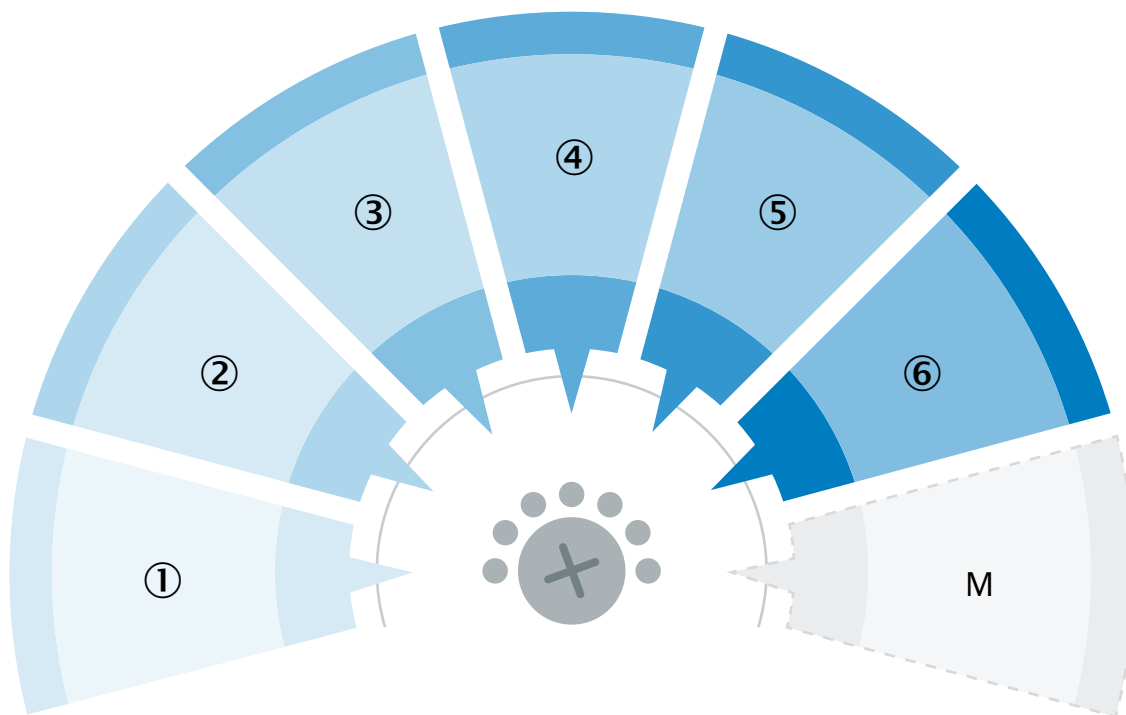

MultiMode settings	
1	Background suppression
2	Foreground suppression
3	Two Value Teach-in
4	Two independent switching points

MultiMode settings	
5	Window Mode
6	ApplicationSelect
M	Manual / measurement

Connection type Cable, 4-wire

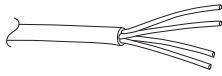

Connection diagram Cd-600 (Mode 1, 2, 3, 5, 6)

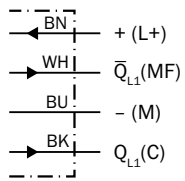

Connection diagram Cd-599 (Mode 4)

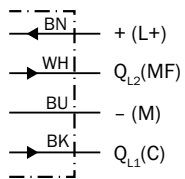

Truth table Push-pull: PNP/NPN – dark switching \bar{Q}_{L2} (MultiMode 4)

	Dark switching \bar{Q}_{L2} (normally closed (upper switch), normally open (lower switch))	
	Object not present → Output HIGH	Object present → Output LOW
Light receive	⊗	☑
Light receive indicator	⊗	☀
Load resistance to L+	⊗	⚡
Load resistance to M	⚡	⊗

Truth table Push-pull: PNP/NPN – light switching Q_{L2} (MultiMode 4)

	Light switching Q_{L2} (normally open (upper switch), normally closed (lower switch))	
	Object not present → Output LOW	Object present → Output HIGH
Light receive	⊗	☑
Light receive indicator	⊗	☀
Load resistance to L+	⚡	⊗
Load resistance to M	⊗	⚡

Truth table Push-pull: PNP/NPN – dark switching \bar{Q}_{L1} (MultiMode 4)

	Dark switching \bar{Q}_{L1} (normally closed (upper switch), normally open (lower switch))	
	Object not present → Output HIGH	Object present → Output LOW
Light receive	✗	✓
Light receive indicator	✗	☀
Load resistance to L+	✗	⚡
Load resistance to M	⚡	✗

Truth table Push-pull: PNP/NPN – light switching Q_{L1} (MultiMode 4)

	Light switching Q_{L1} (normally open (upper switch), normally closed (lower switch))	
	Object not present → Output LOW	Object present → Output HIGH
Light receive	✗	✓
Light receive indicator	✗	☀
Load resistance to L+	⚡	✗
Load resistance to M	✗	⚡

Truth table Push-pull: PNP/NPN – dark switching \bar{Q} (MultiMode 2)

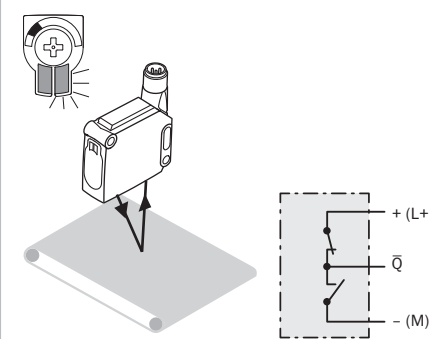
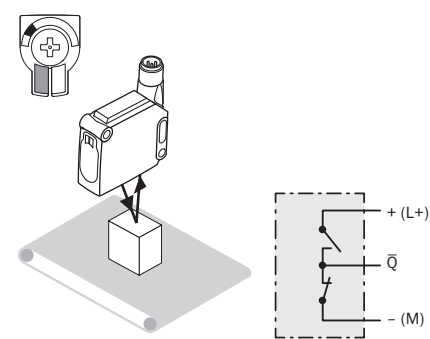
	Dark switching \bar{Q} (normally closed (upper switch), normally open (lower switch))	
	Object not present → Output HIGH	Object present → Output LOW
Light receive	✘	✔
Light receive indicator	✘	☀
Load resistance to L+	✘	⚡
Load resistance to M	⚡	✘
		

Truth table Push-pull: PNP/NPN – light switching Q (MultiMode 2)

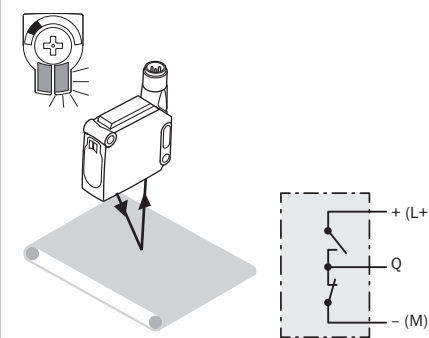
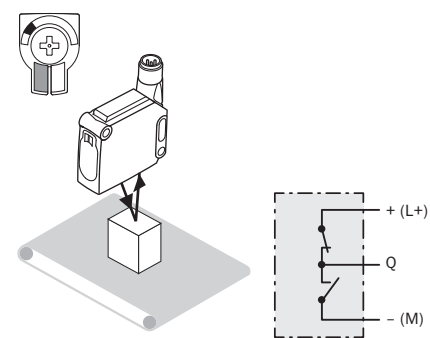
	Light switching Q (normally open (upper switch), normally closed (lower switch))	
	Object not present → Output LOW	Object present → Output HIGH
Light receive	✘	✔
Light receive indicator	✘	☀
Load resistance to L+	⚡	✘
Load resistance to M	✘	⚡
		

Truth table Push-pull: PNP/NPN – light switching Q (MultiMode 1, 3, 5, 6)

	Light switching Q (normally open (upper switch), normally closed (lower switch))	
	Object not present → Output LOW	Object present → Output HIGH
Light receive	✘	✔
Light receive indicator	✘	☀
Load resistance to L+	⚡	✘
Load resistance to M	✘	⚡

Truth table Push-pull: PNP/NPN – dark switching \bar{Q} (MultiMode 1, 3, 5, 6)

	Dark switching \bar{Q} (normally closed (upper switch), normally open (lower switch))	
	Object not present → Output HIGH	Object present → Output LOW
Light receive	✘	✔
Light receive indicator	✘	☀
Load resistance to L+	✘	⚡
Load resistance to M	⚡	✘

Characteristic curve Mode 2 and 6 combined (HighPrecision/LongRange mode)

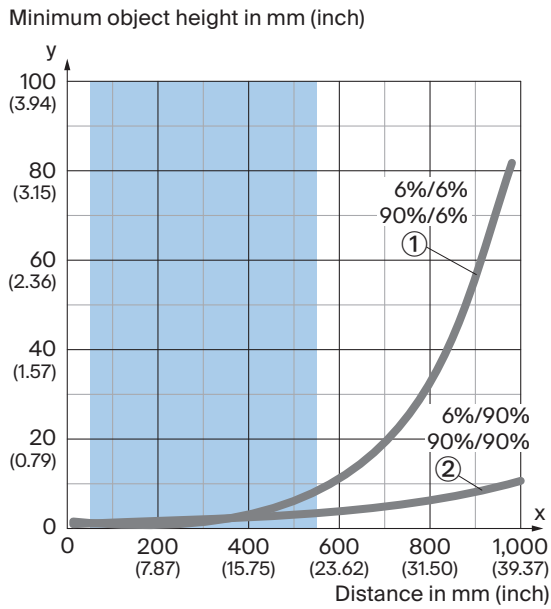

Recommended sensing range for the best performance

- ① Black background, 6% remission factor
- ② White background, 90% remission factor

Example:
Reliable detection of the object

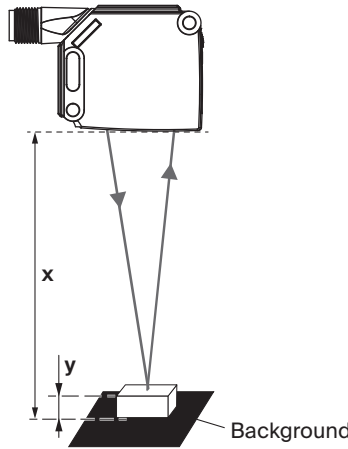

Black background (6 % remission factor)
Distance of sensor to background $x = 400$ mm
Required minimum object height $y = 3$ mm
For all objects regardless of their colors

Characteristic curve Mode 2 and 6 combined (Balanced mode)

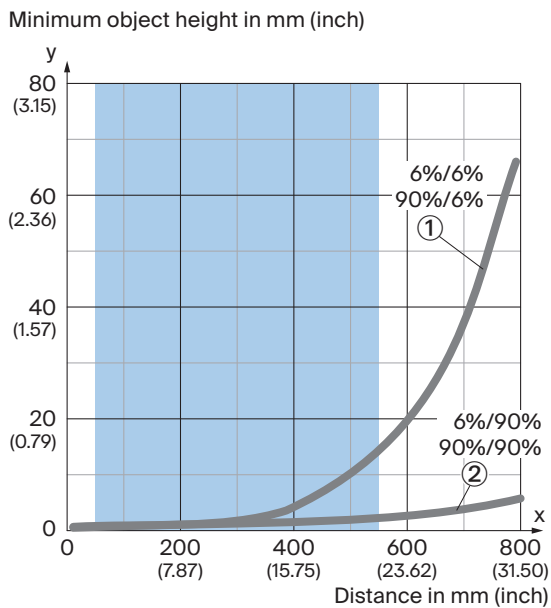

Recommended sensing range for the best performance

- ① Black background, 6% remission factor
- ② White background, 90% remission factor

Example:
Reliable detection of the object

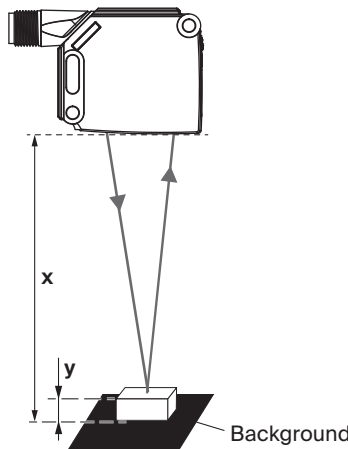

Black background (6 % remission factor)
Distance of sensor to background $x = 400$ mm
Required minimum object height $y = 4$ mm
For all objects regardless of their colors

Characteristic curve Mode 2

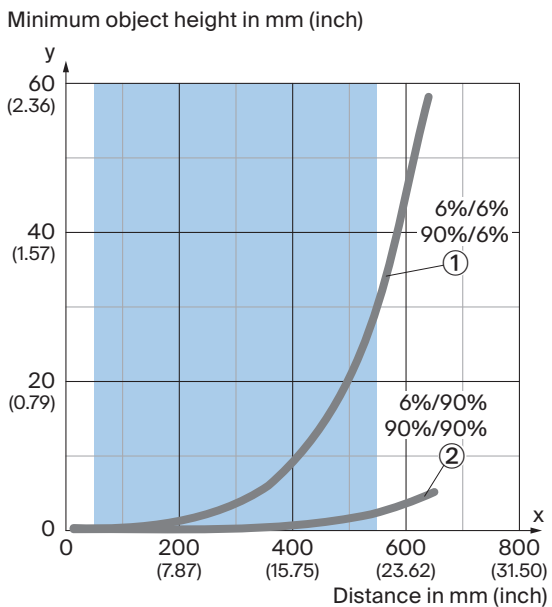

Recommended sensing range for the best performance

- ① Black background, 6% remission factor
- ② White background, 90% remission factor

Example:
Reliable detection of the object

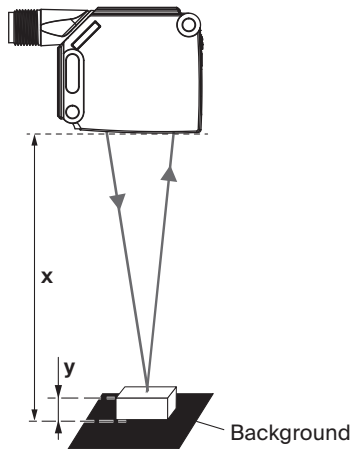

Black background (6 % remission factor)
Distance of sensor to background $x = 400$ mm
Required minimum object height $y = 9$ mm
For all objects regardless of their colors

Characteristic curve Mode 1, 3, 4, 5 combined with 6 (HighPrecision/LongRange mode)

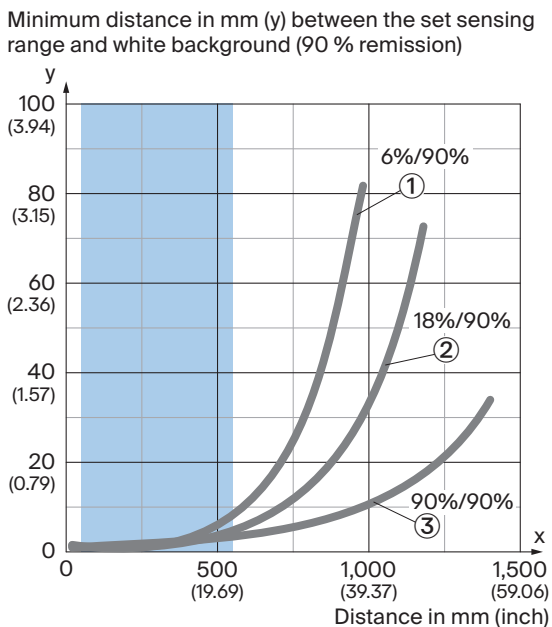

Recommended sensing range for the best performance

- ① Sensing range on black, 6% remission factor
- ② Sensing range on gray, 18% remission factor
- ③ Sensing range on white, 90% remission factor

Example:
Safe suppression of the background

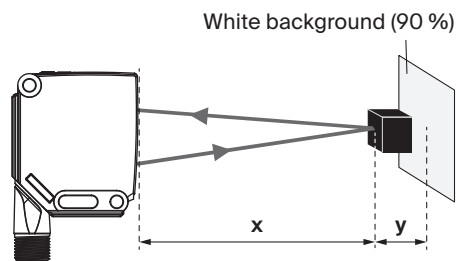

Black object (6 % remission)
Set sensing range $x = 400$ mm
Needed minimum distance to white background $y = 3$ mm

Characteristic curve Mode 1, 3, 4, 5 combined with 6 (Balanced mode)

Minimum distance in mm (y) between the set sensing range and white background (90 % remission)

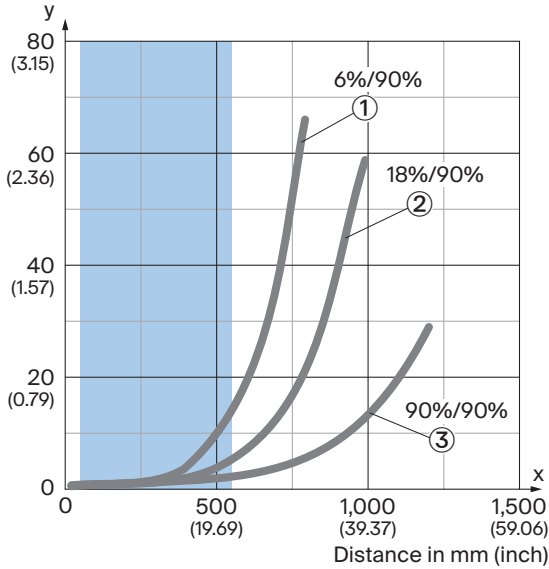

Example:
Safe suppression of the background

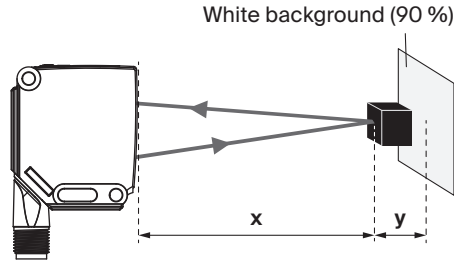

Black object (6 % remission)
Set sensing range x = 400 mm
Needed minimum distance to white background y = 4 mm

Recommended sensing range for the best performance

- ① Sensing range on black, 6% remission factor
- ② Sensing range on gray, 18% remission factor
- ③ Sensing range on white, 90% remission factor

Characteristic curve Mode 1, 3, 4, 5

Minimum distance in mm (y) between the set sensing range and white background (90 % remission)

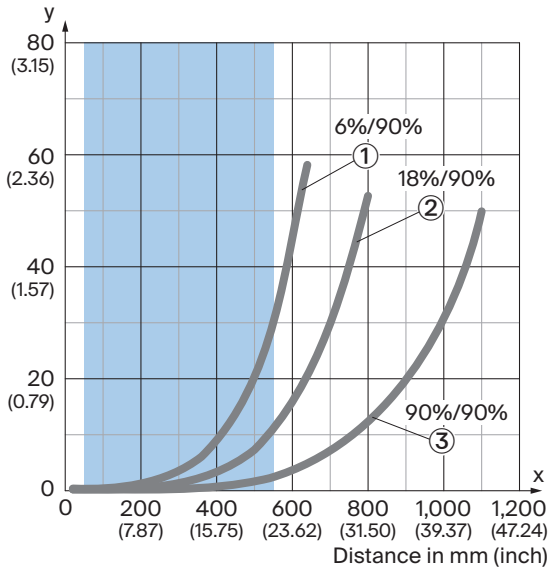

Example:
Safe suppression of the background

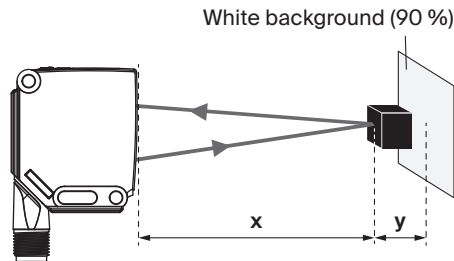

Black object (6 % remission)
Set sensing range x = 400 mm
Needed minimum distance to white background y = 9 mm

Recommended sensing range for the best performance

- ① Sensing range on black, 6% remission factor
- ② Sensing range on gray, 18% remission factor

③ Sensing range on white, 90% remission factor

Light spot size

Dimensions in mm (inch)

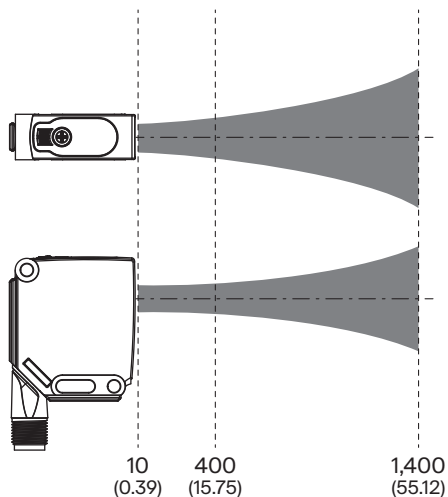
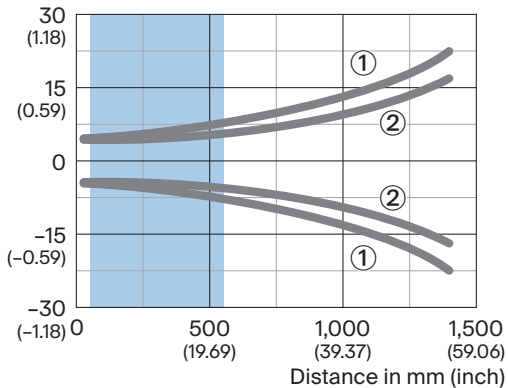

Recommended sensing range for the best performance

- ① Light spot horizontal
- ② Light spot vertical

Sensing range diagram Mode 2 and 6 combined (HighPrecision/LongRange mode)

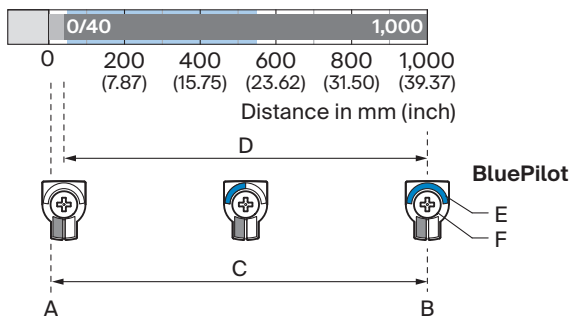

Recommended sensing range for the best performance

A	Sensing range min. in mm
B	Sensing range max. in mm
C	Field of view
D	Adjustable switching threshold for foreground suppression
E	Sensing range indicator
F	Teach-Turn adjustment

Sensing range diagram Mode 2 and 6 combined (Balanced mode)

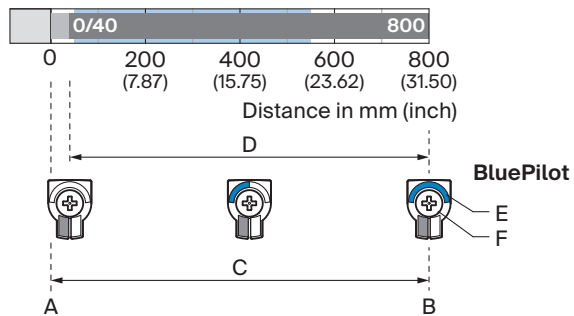

Recommended sensing range for the best performance

A	Sensing range min. in mm
B	Sensing range max. in mm
C	Field of view
D	Adjustable switching threshold for foreground suppression
E	Sensing range indicator
F	Teach-Turn adjustment

Sensing range diagram Mode 2

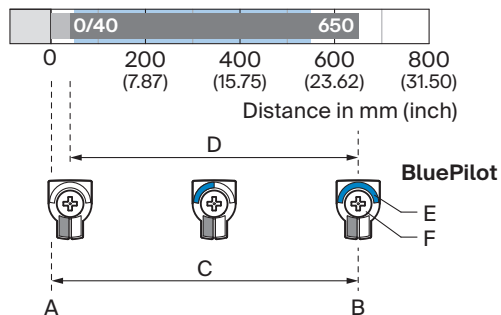

Recommended sensing range for the best performance

A	Sensing range min. in mm
B	Sensing range max. in mm
C	Field of view
D	Adjustable switching threshold for foreground suppression
E	Sensing range indicator
F	Teach-Turn adjustment

Sensing range diagram Mode 1, 3, 4, 5 combined with 6 (HighPrecision/LongRange mode)

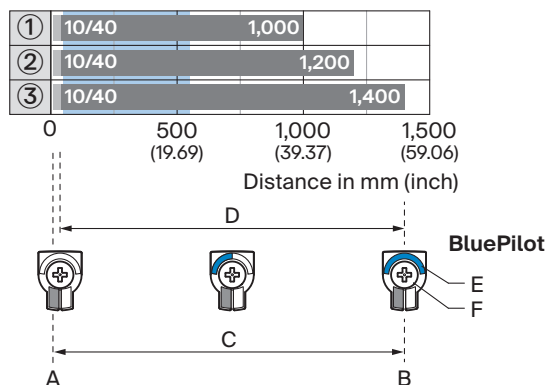

Recommended sensing range for the best performance

1	Black object, 6% remission factor
2	Gray object, 18% remission factor
3	White object, 90% remission factor
A	Sensing range min. in mm
B	Sensing range max. in mm
C	Field of view
D	Adjustable switching threshold for background suppression
E	Sensing range indicator
F	Teach-Turn adjustment

Sensing range diagram Mode 1, 3, 4, 5 combined with 6 (Balanced mode)

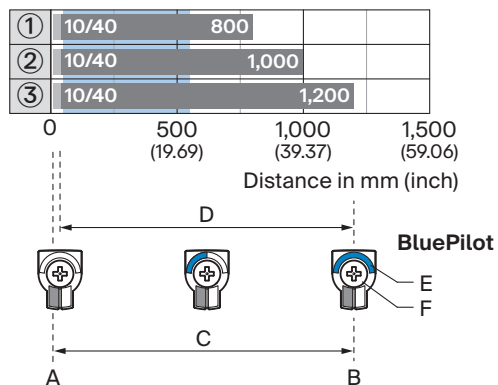

Recommended sensing range for the best performance

1	Black object, 6% remission factor
2	Gray object, 18% remission factor
3	White object, 90% remission factor

A	Sensing range min. in mm
B	Sensing range max. in mm
C	Field of view
D	Adjustable switching threshold for background suppression
E	Sensing range indicator
F	Teach-Turn adjustment

Sensing range diagram Mode 1, 3, 4, 5

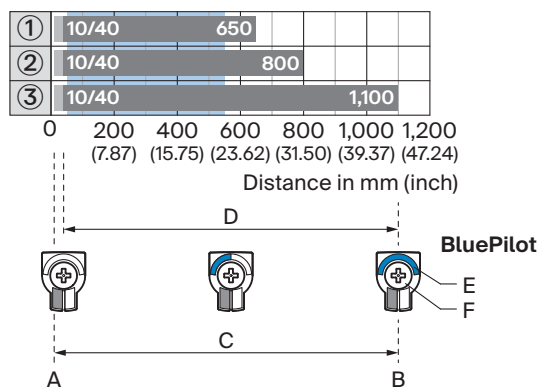

Recommended sensing range for the best performance

1	Black object, 6% remission factor
2	Gray object, 18% remission factor
3	White object, 90% remission factor
A	Sensing range min. in mm
B	Sensing range max. in mm
C	Field of view
D	Adjustable switching threshold for background suppression
E	Sensing range indicator
F	Teach-Turn adjustment

accuracy

Accuracy in mm (inch)

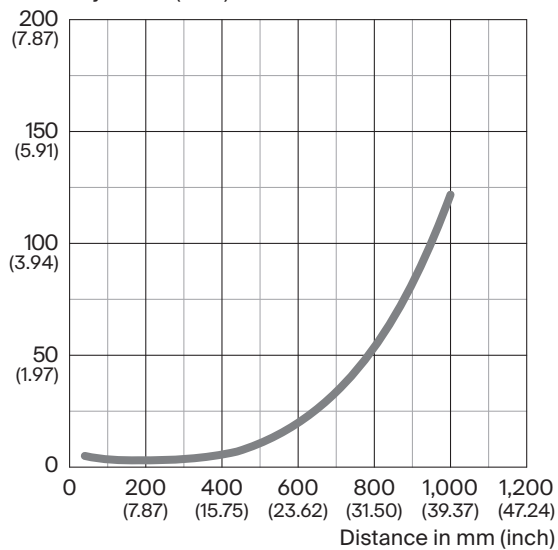

Repeatability

Repeatability in mm (inch)

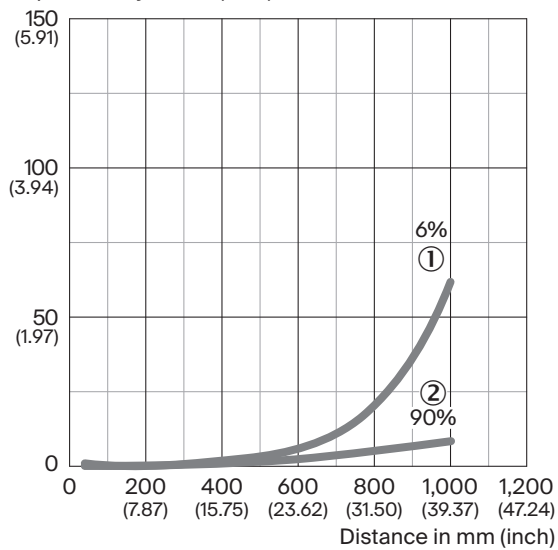

- ① 6 % remission, on black
- ② 90 % remission, on white

Dimensional drawing, sensor

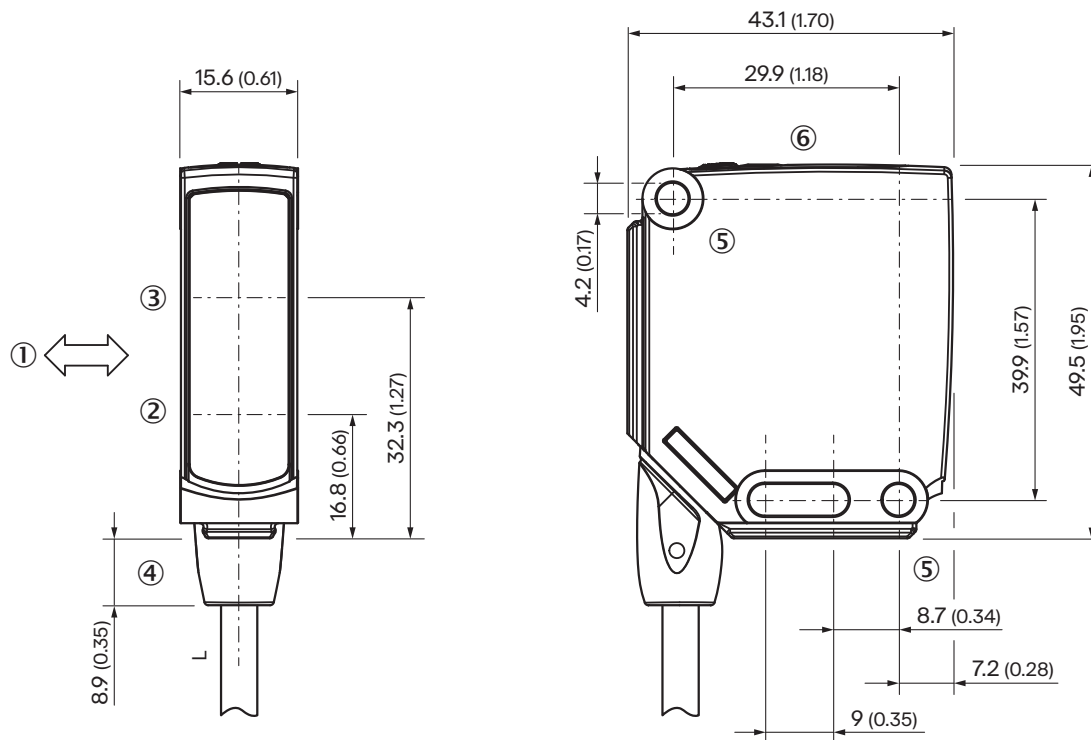





Dimensions in mm (inch)

- ① Standard direction of the material being detected
- ② Center of optical axis, sender
- ③ Center of optical axis, receiver
- ④ Connection
- ⑤ Mounting hole, Ø 4.2 mm
- ⑥ display and adjustment elements

Recommended accessories

Other models and accessories → www.sick.com/W12

	Brief description	Type	part no.
Mounting systems			
	<ul style="list-style-type: none"> • Description: Plate N02N for universal clamp bracket • Material: Stainless steel, stainless steel • Details: Stainless steel 1.4571 (sheet), Stainless steel 1.4408 (clamp) • Items supplied: Universal clamp (5322627), mounting hardware • Usable for: W4S-3 Glass, W10, W4SLG-3, W4S-3 Inox, W4S-3 Inox Glass, W9, W11-2, W12-3, W12-2 Laser, W12G, W12 Teflon, W16, W250, W250-2, PowerProx, W11G-2, TranspaTect, WTT12, UC12, P250, G6 Inox, W4S, W4SL-3V, W4SLG-3V, W4SL-3H 	BEF-KHS-N02N	2051618
	<ul style="list-style-type: none"> • Description: Mounting bracket, large • Material: Stainless steel • Details: Stainless steel • Items supplied: Mounting hardware included • Suitable for: W11-2, W12-3, W16 	BEF-WG-W12	2013942

	Brief description	Type	part no.
connectors and cables			
	<ul style="list-style-type: none"> • Description: Unshielded • Connection type head A: Male connector, M12, 4-pin, straight, A-coded • Connection systems: Screw-type terminals • Permitted cross-section: ≤ 0.75 mm² 	STE-1204-G	6009932
	<ul style="list-style-type: none"> • Description: Unshielded • Connection type head A: Male connector, M8, 4-pin, straight, A-coded • Connection systems: Screw-type terminals • Permitted cross-section: 0.14 mm² ... 0.5 mm² 	STE-0804-G	6037323

SICK AT A GLANCE

SICK is one of the leading manufacturers of intelligent sensors and sensor solutions for industrial applications. A unique range of products and services creates the perfect basis for controlling processes securely and efficiently, protecting individuals from accidents and preventing damage to the environment.

We have extensive experience in a wide range of industries and understand their processes and requirements. With intelligent sensors, we can deliver exactly what our customers need. In application centers in Europe, Asia and North America, system solutions are tested and optimized in accordance with customer specifications. All this makes us a reliable supplier and development partner.

Comprehensive services complete our offering: SICK LifeTime Services provide support throughout the machine life cycle and ensure safety and productivity.

For us, that is “Sensor Intelligence.”

WORLDWIDE PRESENCE:

Contacts and other locations –www.sick.com