



WTS12A-1H161120A00ZDZZZZZZZZZZ1  
W12

PHOTOELECTRIC SENSORS

**SICK**  
Sensor Intelligence.



Illustration may differ

### Ordering information

| Type                          | part no. |
|-------------------------------|----------|
| WTS12A-1H161120A00ZDZZZZZZZZ1 | 1150608  |

Other models and accessories → [www.sick.com/W12](http://www.sick.com/W12)



### Detailed technical data

#### Features

|   |   |
|---|---|
| <b>Functional principle</b>   | Photoelectric proximity sensor  |
| <b>Functional principle detail</b>  | Background suppression, TwinEye technology  |
| <b>Sensing range</b>  |   |
| Sensing range min.  | 18 mm   |
| Sensing range max.  | 600 mm  |
| Adjustable switching threshold for background suppression                                       | 40 mm ... 600 mm  |
| Reference object  | Object with 90% remission factor (complies with standard white according to DIN 5033) |
| Minimum distance between set sensing range and background (black 6% / white 90%)                | 9 mm, at a distance of 200 mm   |
| Recommended sensing range for the best performance  | 50 mm ... 200 mm  |
| <b>Emitted beam</b>   |   |
| Light source  | PinPoint Pro LED  |
| Type of light   | Visible red light   |
| Shape of light spot   | Line-shaped   |
| Light spot size (distance)  | 46 mm x 6 mm (200 mm)   |
| Maximum dispersion of the emitted beam around the standardized transmission axis (squint angle) | < +/- 1.0° (at T <sub>U</sub> = +23 °C)   |
| <b>Focus position</b>   | 300 mm  |

|                             |  |  |
|-----------------------------|--|--|
| <b>Key LED figures</b>      |  |  |
| Normative reference         |  | EN 62471:2008-09   IEC 62471:2006, modified  |
| LED risk group marking      |  | Free group   |
| Wave length                 |  | 635 nm   |
| Average service life        |  | 100,000 h at T <sub>a</sub> = +25 °C   |
| <b>Adjustment</b>           |  |  |
| Teach-Turn adjustment       |  | BluePilot<br>For setting the sensing range   |
| IO-Link                     |  | For configuring the sensor parameters and Smart Task functions                               |
| <b>Display</b>              |  |  |
| LED blue                    |  | BluePilot: sensing range indicator   |
| LED green                   |  | Operating indicator<br>Static on: power on<br>Flashing: IO-Link mode                         |
| LED yellow                  |  | Status of received light beam<br>Static on: object present<br>Static off: object not present |
| <b>Special applications</b> |  | Detecting uneven, shiny objects, Detecting perforated objects                                |

### Safety-related parameters

|                                     |             |
|-------------------------------------|-------------|
| <b>MTTF<sub>D</sub></b>             | 1,208 years |
| <b>DC<sub>avg</sub></b>             | 0 %         |
| <b>T<sub>M</sub> (mission time)</b> | 20 years    |

### Communication interface

|                             |   |
|-----------------------------|---|
| <b>IO-Link</b>              | ✓, IO-Link V1.1   |
| Data transmission rate      | COM2 (38,4 kBaud)   |
| Cycle time                  | 2.3 ms  |
| Process data length         | 8 Bit   |
| Process data structure      | Bit 0 = switching signal<br>Bit 1 = switching signal Q <sub>L1</sub><br>Bit 2 = switching signal Q <sub>L2</sub><br>Bit 3 ... 7 = empty |
| VendorID                    | 26  |
| DeviceID HEX                | 0x80039C  |
| DeviceID DEC                | 8389532   |
| Compatible master port type | A   |
| SIO mode support            | Yes   |

### Electronics

|                                     |  |
|-------------------------------------|--|
| <b>Supply voltage U<sub>B</sub></b> | 10 V DC ... 30 V DC <sup>1)</sup>                                      |
| <b>Ripple</b>                       | ≤ 5 V  |
| <b>Usage category</b>               | DC-12 (According to EN 60947-5-2)<br>DC-13 (According to EN 60947-5-2) |

<sup>1)</sup> Limit values.

<sup>2)</sup> This switching output must not be connected to another output.

|                                       |   |
|---------------------------------------|---|
| <b>Current consumption</b>            | ≤ 40 mA, without load. At $U_B = 24\text{ V}$   |
| <b>Protection class</b>               | III   |
| <b>Digital output</b>                 |   |
| Number                                | 2 (Complementary)   |
| Type                                  | Push-pull: PNP/NPN  |
| Switching mode                        | Light/dark switching  |
| Signal voltage PNP HIGH/LOW           | Approx. $U_B - 2.5\text{ V} / 0\text{ V}$   |
| Signal voltage NPN HIGH/LOW           | Approx. $U_B / < 2.5\text{ V}$  |
| Output current $I_{\max}$             | ≤ 100 mA  |
| Circuit protection outputs            | Reverse polarity protected  |
|                                       | Overcurrent protected   |
|                                       | Short-circuit protected   |
| Response time                         | ≤ 330 μs  |
| Repeatability (response time)         | 100 μs  |
| Switching frequency                   | 1,500 Hz  |
| <b>Pin/Wire assignment</b>            |   |
| Function of pin 4/black (BK)          | Digital output, dark switching, object present → output $\bar{Q}_{L1}\text{ HIGH}^{2)}$ |
|                                       | IO-Link communication C   |
| Function of pin 4/black (BK) – detail | The pin 4 function of the sensor can be configured                                      |
|                                       | Additional possible settings via IO-Link  |
| Function of pin 2/white (WH)          | Digital output, light switching, object present → output $Q_{L1}\text{ LOW}^{2)}$       |
| Function of pin 2/white (WH) – detail | The pin 2 function of the sensor can be configured                                      |
|                                       | Additional possible settings via IO-Link  |

<sup>1)</sup> Limit values.

<sup>2)</sup> This switching output must not be connected to another output.

## Mechanics

|                               |  |
|-------------------------------|--|
| <b>Housing</b>                | Rectangular                            |
| <b>Dimensions (W x H x D)</b> | 15.6 mm x 49.5 mm x 43.1 mm            |
| <b>Connection</b>             | Cable, 4-wire, 2 m                     |
| <b>Connection detail</b>      |  |
| Deep-freeze property          | Do not bend below 0 °C                 |
| Conductor size                | 0.14 mm <sup>2</sup>                   |
| Cable diameter                | ∅ 3.4 mm                               |
| Length of cable (L)           | 2 m                                    |
| Bending radius                | For flexible use > 12 x cable diameter |
| Bending cycles                | 1,000,000                              |
| <b>Material</b>               |  |
| Housing                       | Metal, zinc diecast                    |
| Front screen                  | Plastic, PMMA                          |
| Cable                         | Plastic, PVC                           |
| <b>Weight</b>                 | Approx. 132 g                          |

|   |        |
|---|--------|
| <b>Maximum tightening torque of the fixing screws</b> | 1.4 Nm |
|---|--------|

## Ambient data

|  |   |
|--|---|
| <b>Enclosure rating</b>                    | IP66 (EN 60529)<br>IP67 (EN 60529)<br>IP69 (EN 60529)   |
| <b>Ambient operating temperature</b>       | -40 °C ... +60 °C   |
| <b>Ambient temperature, storage</b>        | -40 °C ... +75 °C   |
| <b>Typ. Ambient light immunity</b>         | Artificial light: ≤ 50,000 lx<br>Sunlight: ≤ 50,000 lx  |
| <b>Shock resistance</b>                    | 50 g, 11 ms (25 positive and 25 negative shocks along X, Y, Z axes, 150 total shocks (EN60068-2-27))            |
| <b>Vibration resistance</b>                | 10 Hz ... 2,000 Hz (Amplitude 0.5 mm / 10 g, 20 sweeps per axis, for X, Y, Z axes, 1 octave/min, (EN60068-2-6)) |
| <b>Air humidity</b>                        | 35 % ... 95 %, relative humidity (no condensation)  |
| <b>Electromagnetic compatibility (EMC)</b> | EN 60947-5-2  |
| <b>Resistance to cleaning agent</b>        | ECOLAB  |
| <b>UL File No.</b>                         | NRKH.E181493 & NRKH7.E181493  |

## Smart Task

|                                 |   |
|---------------------------------|---|
| <b>Smart Task name</b>          | Base logics   |
| <b>Logic function</b>           | Direct<br>AND<br>OR   |
| <b>Timer function</b>           | Deactivated<br>Switch-on delay<br>Off delay<br>ON and OFF delay<br>Impulse (one shot) |
| <b>Inverter</b>                 | Yes   |
| <b>Switching frequency</b>      | SIO Logic: 1300 Hz <sup>1)</sup><br>IOL: 1200 Hz <sup>2)</sup>                        |
| <b>Response time</b>            | SIO Logic: 390 μs <sup>1)</sup><br>IOL: 420 μs <sup>2)</sup>                          |
| <b>Repeatability</b>            | SIO Logic: 140 μs <sup>1)</sup><br>IOL: 170 μs <sup>2)</sup>                          |
| <b>Switching signal</b>         |   |
| Switching signal $Q_{L1}$       | Switching output  |
| Switching signal $\bar{Q}_{L1}$ | Switching output  |

<sup>1)</sup> Use of Smart Task functions without IO-Link communication (SIO mode).

<sup>2)</sup> Use of Smart Task functions with IO-Link communication function.

## Diagnosis

|                               |                                      |
|-------------------------------|--------------------------------------|
| <b>Device temperature</b>     |                                      |
| Measuring range               | Very cold, cold, moderate, warm, hot |
| <b>Device status</b>          | Yes                                  |
| <b>Detailed device status</b> | Yes                                  |
| <b>Operating hour counter</b> | Yes                                  |

|  |     |
|--|-----|
| <b>Operating hours counter with reset function</b> | Yes |
| <b>Quality of teach</b>                            | Yes |

Certificates

|  |   |
|--|---|
| <b>EU declaration of conformity</b>  | ✓ |
| <b>UK declaration of conformity</b>  | ✓ |
| <b>ACMA declaration of conformity</b>  | ✓ |
| <b>Moroccan declaration of conformity</b>                                    | ✓ |
| <b>China RoHS</b>  | ✓ |
| <b>ECOLAB certificate</b>  | ✓ |
| <b>cULus certificate</b>   | ✓ |
| <b>IO-Link certificate</b>   | ✓ |
| <b>Photobiological safety (IEC EN 62471)</b>                                 | ✓ |
| <b>Information according to Art. 3 of Data Act (Regulation EU 2023/2854)</b> | ✓ |

Classifications

|                       |          |
|-----------------------|----------|
| <b>ECLASS 5.0</b>     | 27270904 |
| <b>ECLASS 5.1.4</b>   | 27270904 |
| <b>ECLASS 6.0</b>     | 27270904 |
| <b>ECLASS 6.2</b>     | 27270904 |
| <b>ECLASS 7.0</b>     | 27270904 |
| <b>ECLASS 8.0</b>     | 27270904 |
| <b>ECLASS 8.1</b>     | 27270904 |
| <b>ECLASS 9.0</b>     | 27270904 |
| <b>ECLASS 10.0</b>    | 27270904 |
| <b>ECLASS 11.0</b>    | 27270904 |
| <b>ECLASS 12.0</b>    | 27270903 |
| <b>ETIM 5.0</b>       | EC002719 |
| <b>ETIM 6.0</b>       | EC002719 |
| <b>ETIM 7.0</b>       | EC002719 |
| <b>ETIM 8.0</b>       | EC002719 |
| <b>UNSPSC 16.0901</b> | 39121528 |

Dimensional drawing, sensor

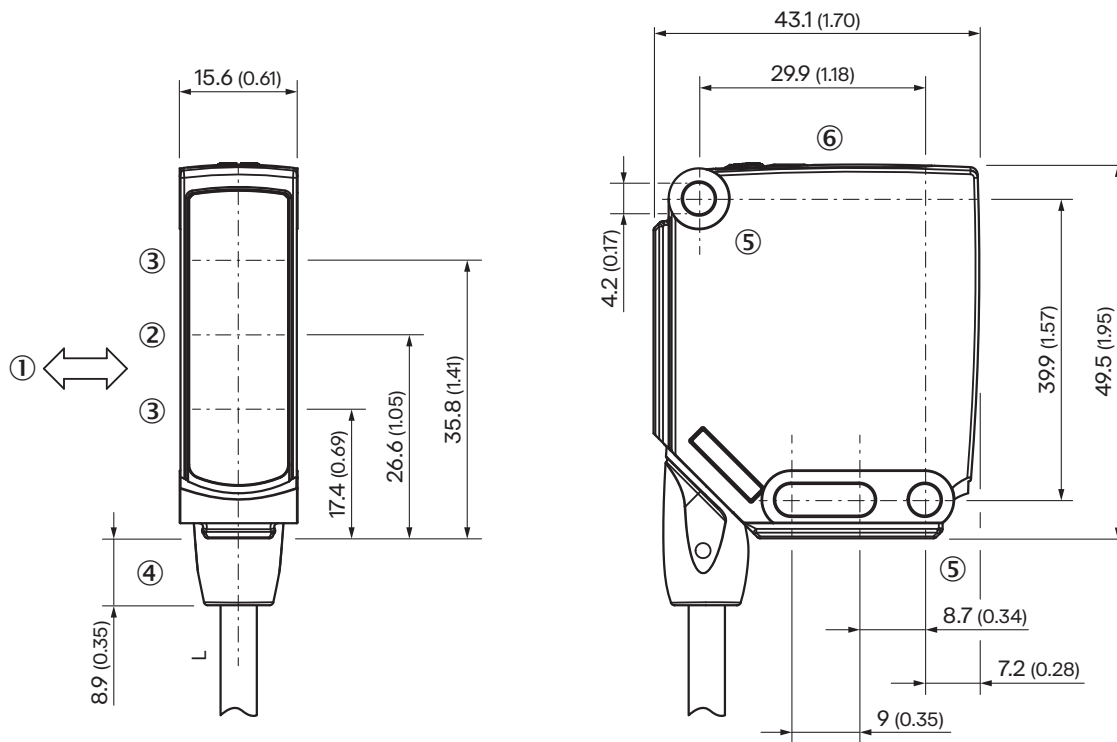

Dimensions in mm (inch)

- ① Standard direction of the material being detected
- ② Center of optical axis, sender
- ③ Center of optical axis, receiver
- ④ Connection
- ⑤ Mounting hole,  $\varnothing$  4.2 mm
- ⑥ display and adjustment elements

display and adjustment elements

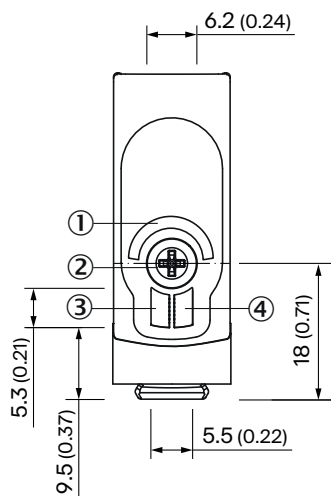

- ① LED blue
- ② Teach-Turn adjustment
- ③ LED green

④ LED yellow

Connection type Cable, 4-wire

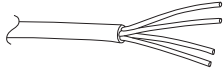

Connection diagram Cd-491

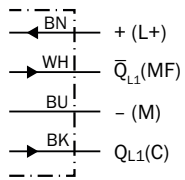

Truth table Push-pull: PNP/NPN - light switching Q

|                         | Light switching Q (normally open (upper switch), normally closed (lower switch)) |                              |
|-------------------------|--|------------------------------|
|                         | Object not present → Output LOW  | Object present → Output HIGH |
| Light receive           | ✘  | ✔                            |
| Light receive indicator | ✘  | ☀                            |
| Load resistance to L+   | ⚡  | ✘                            |
| Load resistance to M    | ✘  | ⚡                            |
|                         |  |                              |

Truth table Push-pull: PNP/NPN – dark switching  $\bar{Q}$

|                         | Dark switching $\bar{Q}$ (normally closed (upper switch), normally open (lower switch)) |                             |
|-------------------------|---|-----------------------------|
|                         | Object not present → Output HIGH  | Object present → Output LOW |
| Light receive           | ⊗   | ☑                           |
| Light receive indicator | ⊗   | ☀                           |
| Load resistance to L+   | ⊗   | ⚡                           |
| Load resistance to M    | ⚡   | ⊗                           |
|                         |   |                             |

Characteristic curve

Minimum distance in mm (y) between the set sensing range and white background (90 % remission)

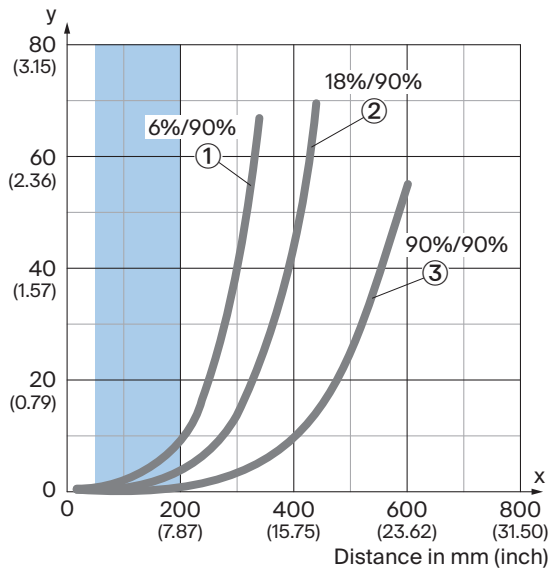

Example:  
Safe suppression of the background

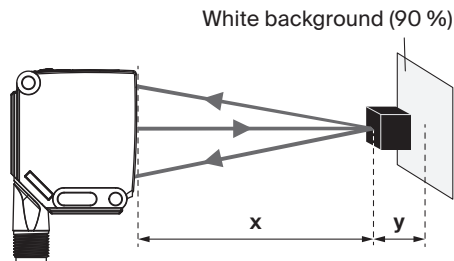

Black object (6 % remission)  
Set sensing range  $x = 200$  mm  
Needed minimum distance to white background  $y = 9$  mm

Recommended sensing range for the best performance

- ① Sensing range on black, 6% remission factor
- ② Sensing range on gray, 18% remission factor
- ③ Sensing range on white, 90% remission factor

Light spot size

Dimensions in mm (inch)

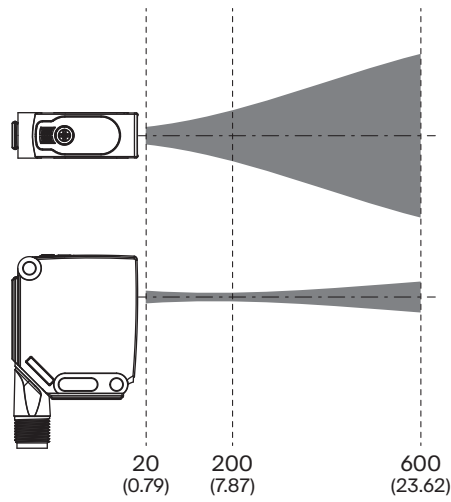
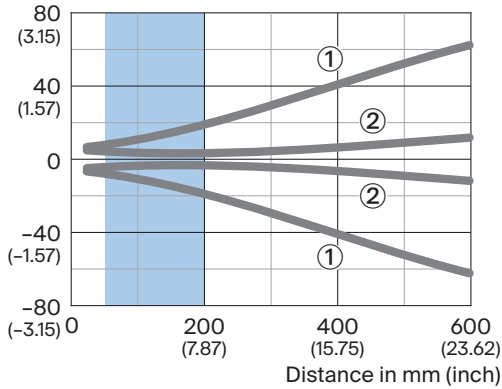

Recommended sensing range for the best performance

- ① Light spot horizontal
- ② Light spot vertical

Sensing range diagram

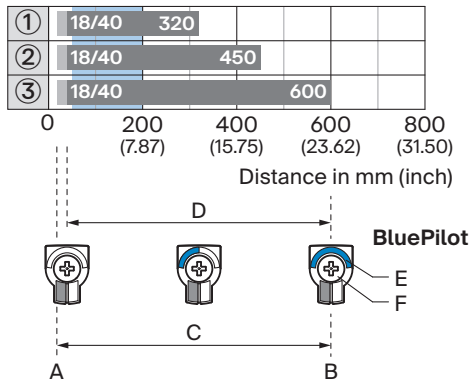





Recommended sensing range for the best performance

|   |   |
|---|---|
| 1 | Black object, 6% remission factor                         |
| 2 | Gray object, 18% remission factor                         |
| 3 | White object, 90% remission factor                        |
| A | Sensing range min. in mm                                  |
| B | Sensing range max. in mm                                  |
| C | Field of view   |
| D | Adjustable switching threshold for background suppression |
| E | Sensing range indicator                                   |
| F | Teach-Turn adjustment                                     |

Recommended accessories

Other models and accessories → [www.sick.com/W12](http://www.sick.com/W12)

|  | Brief description   | Type         | part no. |
|--|---|--------------|----------|
| Mounting systems   |   |              |          |
|   | <ul style="list-style-type: none"> <li><b>Description:</b> Plate N02N for universal clamp bracket</li> <li><b>Material:</b> Stainless steel, stainless steel</li> <li><b>Details:</b> Stainless steel 1.4571 (sheet), Stainless steel 1.4408 (clamp)</li> <li><b>Items supplied:</b> Universal clamp (5322627), mounting hardware</li> <li><b>Usable for:</b> W4S-3 Glass, W10, W4SLG-3, W4S-3 Inox, W4S-3 Inox Glass, W9, W11-2, W12-3, W12-2 Laser, W12G, W12 Teflon, W16, W250, W250-2, PowerProx, W11G-2, TranspaTect, WTT12, UC12, P250, G6 Inox, W4S, W4SL-3V, W4SLG-3V, W4SL-3H</li> </ul> | BEF-KHS-N02N | 2051618  |
|   | <ul style="list-style-type: none"> <li><b>Description:</b> Mounting bracket, large</li> <li><b>Material:</b> Stainless steel</li> <li><b>Details:</b> Stainless steel</li> <li><b>Items supplied:</b> Mounting hardware included</li> <li><b>Suitable for:</b> W11-2, W12-3, W16</li> </ul>   | BEF-WG-W12   | 2013942  |
| connectors and cables  |   |              |          |
|   | <ul style="list-style-type: none"> <li><b>Description:</b> Unshielded</li> <li><b>Connection type head A:</b> Male connector, M12, 4-pin, straight, A-coded</li> <li><b>Connection systems:</b> Screw-type terminals</li> <li><b>Permitted cross-section:</b> ≤ 0.75 mm<sup>2</sup></li> </ul>  | STE-1204-G   | 6009932  |
|  | <ul style="list-style-type: none"> <li><b>Description:</b> Unshielded</li> <li><b>Connection type head A:</b> Male connector, M8, 4-pin, straight, A-coded</li> <li><b>Connection systems:</b> Screw-type terminals</li> <li><b>Permitted cross-section:</b> 0.14 mm<sup>2</sup> ... 0.5 mm<sup>2</sup></li> </ul>  | STE-0804-G   | 6037323  |

## SICK AT A GLANCE

SICK is one of the leading manufacturers of intelligent sensors and sensor solutions for industrial applications. A unique range of products and services creates the perfect basis for controlling processes securely and efficiently, protecting individuals from accidents and preventing damage to the environment.

We have extensive experience in a wide range of industries and understand their processes and requirements. With intelligent sensors, we can deliver exactly what our customers need. In application centers in Europe, Asia and North America, system solutions are tested and optimized in accordance with customer specifications. All this makes us a reliable supplier and development partner.

Comprehensive services complete our offering: SICK LifeTime Services provide support throughout the machine life cycle and ensure safety and productivity.

For us, that is “Sensor Intelligence.”

## WORLDWIDE PRESENCE:

Contacts and other locations –[www.sick.com](http://www.sick.com)