



PICS150-01000 Core

picoScan100

2D LIDAR SENSORS

SICK
Sensor Intelligence.



Ordering information

Type	part no.
PICS150-01000 Core	1150207

Other models and accessories → www.sick.com/picoScan100



Detailed technical data

Features

Application	Indoor, Outdoor
Variant	Standard (not pre-configured)
Measurement principle	HDDM ⁺
Light source	Infrared (905 nm)
Laser class	1 (IEC 60825-1:2014, EN 60825-1:2014+A11:2021)
Aperture angle	Horizontal 276°
Scanning frequency	15 Hz 25 Hz Depends on the Dynamic Sensing Profile ¹⁾
Angular resolution	Horizontal 0.25° 0.33° 1° Depends on the Dynamic Sensing Profile ¹⁾
Scan field flatness	± 1°
Working range	0.05 m ... 25 m ¹⁾
Blind zone	0 m ... 0.05 m
Scanning range	At 90% remission factor and 10 klx 25 m At 10% remission factor and 10 klx 12 m
Spot size	Divergence, typ.: 4.8 mrad On the optics cover: 8 mm
Amount of evaluated echoes	3

¹⁾ For details, see the working range diagram in the technical drawings section.

Mechanics/electronics

Connection type	1 x "Ethernet" connection, 4-pin M12 female connector, D-coded 1 x "POWER" connection, 5-pin M12 plug, A-coded
System plug	See system plug 2116047, Assembled downwards
Supply voltage	9 V DC ... 30 V DC
Power consumption	Typ. 4.5 W, max. 17 W with loaded digital outputs, see system plug 2116047
Output current	≤ 200 mA
Housing material	Aluminum with Suretec650 coating
Housing color	Anthracite gray (RAL 7016)
Optical hood	Polycarbonate, scratch-resistant coating
Enclosure rating	IP65 (IEC 60529:1989+AMD1:1999+AMD2:2013) ¹⁾ IP67 (IEC 60529:1989+AMD1:1999+AMD2:2013) ¹⁾
Protection class	III (IEC 61140:2016-11)
Electrical safety	IEC 61010-1:2010-06+AMD1:2016
Weight	220 g, without system plug
Dimensions (L x W x H)	60 mm x 60 mm x 82 mm
Ventilation element	Yes
MTBF	> 100 years
MTTFd	> 100 years (at 25 °C ambient temperature), EN ISO 13849-1:2015

¹⁾ With system plug connected.

Safety-related parameters

MTTF_D	> 100 years, at 25 °C ambient temperature (EN ISO 13849-1:2015)
-------------------------	---

Functions

Digital add-ons	Reliability package Multi-echo technology
------------------------	--

Performance

Data output per scan segment	Segment size 30° at ≤ 25 Hz, Segment size 60° at ≥ 30 Hz
Scan/frame rate	12,546 measurement point/s ... 264,963 measurement point/s, Depends on the Dynamic Sensing Profile and number of echoes
Detectable object shape	Almost any
Systematic error	Typ. ± 20 mm ¹⁾ Max. ± 30 mm
Statistical error	≤ 2 mm (0.05 m ... 5 m) ²⁾
Integrated application	2D Object Detection 2D Object Detection Advanced
Number of field sets	48 fields
Simultaneous evaluation cases	Max. 20 (The number of simultaneous evaluation cases depends on the field geometry)

¹⁾ Typical value; real value depends on ambient conditions and the selected Dynamic Sensing Profile.

²⁾ 10 klx and 100 klx.

Interfaces

Ethernet	✓
Function	Field status information, DHCP, NTP
Data transmission rate	10 Mbit/s ... 100 Mbit/s, half/full-duplex

Digital inputs/outputs	3, customizable, see system plug 2116047
Optical indicators	2 LEDs
Configuration software	SOPASair (web browser) SOPAS ET (software) REST API
Driver	ROS1, ROS2, C++, Python

Ambient data

Remission factor	1.8 % ... > 1,000 % (Reflector)
Electromagnetic compatibility (EMC)	
Emitted radiation	Industrial environment (IEC 61000-6-4:2018 / EN IEC 61000-6-4:2019 / IEC 61000-6-4:2006+A1:2010 / EN 61000-6-4:2007+A1:2011)
Emitted radiation	Business and commercial areas as well as small enterprises (IEC 61000-6-8:2020 / EN IEC 61000-6-8:2020)
Electromagnetic immunity	Industrial environment (IEC 61000-6-2:2016 / EN IEC 61000-6-2:2019 / IEC 61000-6-2:2005 / EN 61000-6-2:2005 / EN 61000-6-2:2005/AC:2005)
Application areas	Automotive (UN ECE R10) ¹⁾
Application areas	Agricultural and forestry machinery (ISO 14982-1, ISO 14982-2) ^{1) 2)}
Application areas	Earthmoving and construction machinery (ISO 13766-1) ^{1) 2)}
Vibration resistance	
Sine resonance scan	10 Hz ... 1,000 Hz, 1 g ³⁾
Sine test	10 Hz ... 500 Hz, 10 g, 10 frequency cycles ³⁾
Noise test	10 Hz ... 500 Hz, 13.5 g RMS, 5 h ⁴⁾
	Short restriction in measurement data availability possible during peak loads.
Shock resistance	
	100 g, 6 ms, ± 3 single shocks/axis ⁵⁾
	40 g, 6 ms, ± 4,000 continuous shocks/axis ⁵⁾
	50 g, 3 ms, ± 5,000 continuous shocks/axis ⁵⁾
	Short restriction in measurement data availability possible.
Ambient operating temperature	-33 °C ... +50 °C
Storage temperature	-40 °C ... +70 °C
Temperature change	-33 °C ... +50 °C, 10 cycles ⁶⁾
Damp heat	
Cyclical	+ 25 °C ... + 55 °C, 95 % RH, non-condensing (operation/storage/transport) (EN 60068-2-30)
Static	+ 40 °C, 93 % RH, non-condensing (operation) (EN 60068-2-78)
Permissible relative humidity	
Operation	< 80 %, Non-condensing (EN 60068-2-30:2005)
Storage	≤ 90 %, Non-condensing (EN 60068-2-30:2005)
Ambient light immunity	100 klx, indirect
Altitude (above sea level)	< 5,000 m

¹⁾ Load dump: from ISO 16750-2 Test B Severity Level 4 passed for 12 V systems. Required in case of transient disturbances on the input filtering signal lines (de-bounce > 10 ms).

²⁾ The requirements of ISO 13766-1 and DIN EN ISO 14982-1 for immunity to electrostatic discharge (ESD) are only met in areas that can be easily touched from the outside.

³⁾ IEC 60068-2-6:2007.

⁴⁾ IEC 60068-2-64:2008.

⁵⁾ IEC 60068-2-27:2008.

⁶⁾ EN 60068-2-14:2009.

General notes

Note on use	The sensor does not constitute a safety component as defined by relevant legislation on machine safety.
--------------------	---

Certificates

EU declaration of conformity	✓
UK declaration of conformity	✓
ACMA declaration of conformity	✓
China RoHS	✓
cTUVus certificate	✓
Information according to Art. 3 of Data Act (Regulation EU 2023/2854)	✓

Classifications

ECLASS 5.0	27270990
ECLASS 5.1.4	27270990
ECLASS 6.0	27270913
ECLASS 6.2	27270913
ECLASS 7.0	27270913
ECLASS 8.0	27270913
ECLASS 8.1	27270913
ECLASS 9.0	27270913
ECLASS 10.0	27270913
ECLASS 11.0	27270913
ECLASS 12.0	27270913
ETIM 5.0	EC002550
ETIM 6.0	EC002550
ETIM 7.0	EC002550
ETIM 8.0	EC002550
UNSPSC 16.0901	41111615

Dimensional drawing

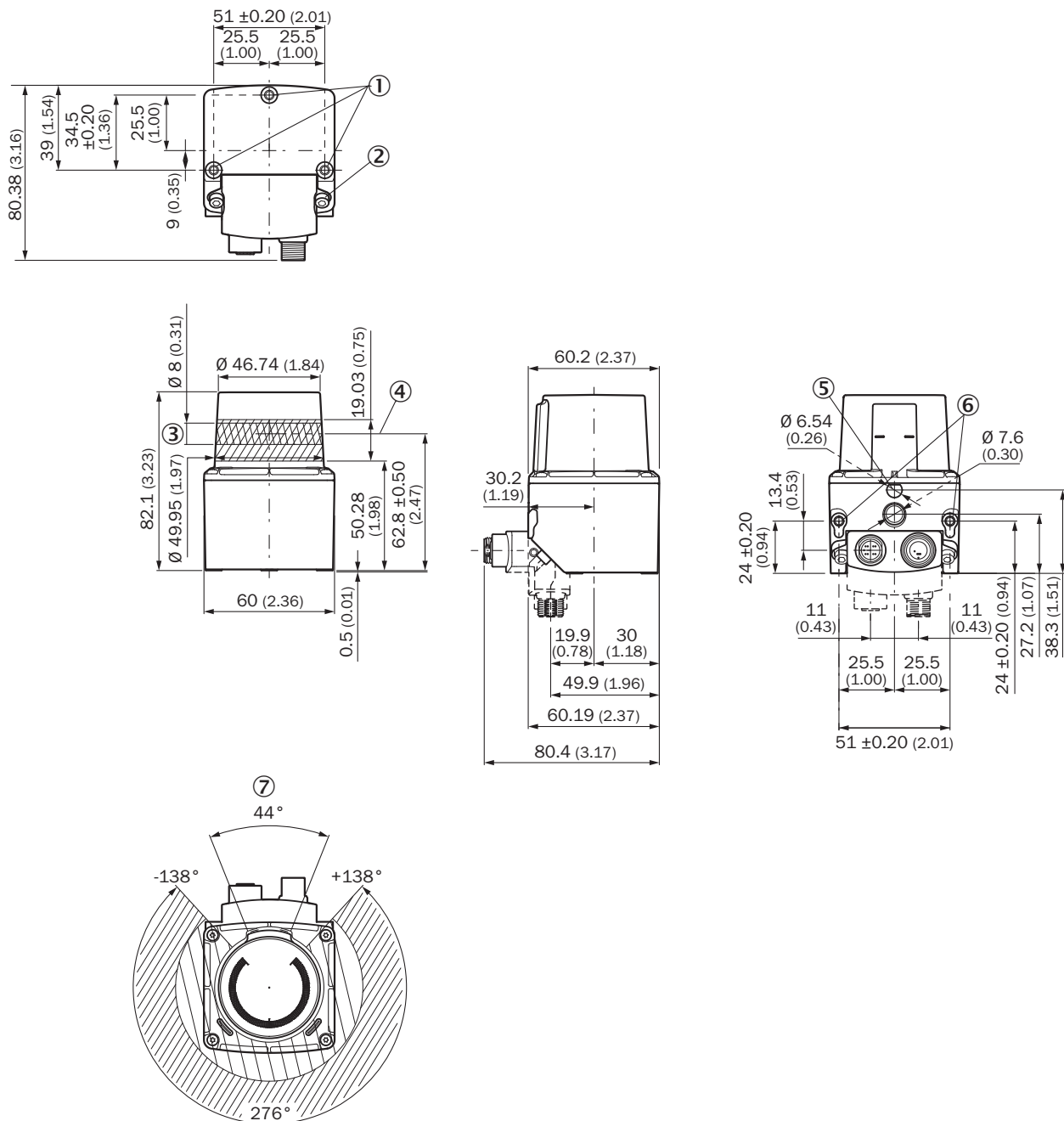

Dimensions in mm (inch)

- ① M4 threaded mounting hole; 4.2 mm deep; tightening torque 2.5 nm
- ② Tightening torque 2.5 nm, screw included in plug unit
- ③ Sending area
- ④ Transmission axis
- ⑤ Support point
- ⑥ M4 threaded mounting hole; 5.4 mm deep, tightening torque 2.5 nm
- ⑦ Area in which no reflective surfaces are allowed for mounted devices

Working range diagram Working range for picoScan150 Core

Scanning range in m (ft)



- Scanning range max. 25 m (82.02 feet)
Scanning range typical 25 m (82.02 feet)
for objects up to 90 % remission
- Scanning range typical 12 m (39.37 feet)
for objects up to 10 % remission

All specified working range values apply to the “Standard” sensitivity mode

Dynamic Sensing Profile	Minimum		Typical			
	100 klx		10 klx		100 klx	
	10 %	90 %	10 %	90 %	10 %	90 %
15 Hz & 0.33°	10 m	25 m	12 m	25 m	10 m	25 m
15 Hz & 1°	10 m	25 m	12 m	25 m	10 m	25 m
25 Hz & 0.25°	10 m	25 m	12 m	25 m	10 m	25 m

Connection type Ethernet



M12 female connector, 4-pin, D-coded

- ① TX+
- ② RX+
- ③ TX-
- ④ RX-

PIN assignment

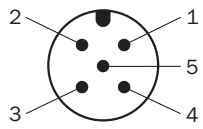

- ① V_s
- ② I/O 2
- ③ GND
- ④ I/O 1
- ⑤ I/O 3

SICK AT A GLANCE

SICK is one of the leading manufacturers of intelligent sensors and sensor solutions for industrial applications. A unique range of products and services creates the perfect basis for controlling processes securely and efficiently, protecting individuals from accidents and preventing damage to the environment.

We have extensive experience in a wide range of industries and understand their processes and requirements. With intelligent sensors, we can deliver exactly what our customers need. In application centers in Europe, Asia and North America, system solutions are tested and optimized in accordance with customer specifications. All this makes us a reliable supplier and development partner.

Comprehensive services complete our offering: SICK LifeTime Services provide support throughout the machine life cycle and ensure safety and productivity.

For us, that is “Sensor Intelligence.”

WORLDWIDE PRESENCE:

Contacts and other locations –www.sick.com