



DATA SHEET

# WTB4FT-97A1120ZZZ

W4  
Photoelectric sensors

PHOTOELECTRIC SENSORS

WT-  
B4FT-97A11120ZZZ

ORDERING INFORMATION

Type	part no.
WTB4FT-97A11120ZZZ	1148339

Further device versions and accessories at [www.sick.com/W4](http://www.sick.com/W4)



Illustration may differ

DETAILED TECHNICAL DATA

FEATURES

Functional principle	Photoelectric proximity sensor	
Functional principle detail	Background suppression, DoubleLine	
Sensing range	Sensing range min.	7 mm
	Sensing range max.	120 mm
Adjustable switching threshold for background suppression	15 mm ... 120 mm	
	Reference object	Object with 90% remission factor (complies with standard white according to DIN 5033)
Minimum distance between set sensing range and background (black 6% / white 90%)	1 mm, at a distance of 50 mm	
Recommended sensing range for the best performance	30 mm ... 80 mm	
Emitted beam	Light source	PinPoint LED
	Type of light	Visible red light
	Shape of light spot	DoubleLine, two parallel line-shaped light spots
	Light spot size (distance)	1.2 mm x 17 mm (50 mm)
	Maximum dispersion of the emitted beam around the standardized transmission axis (squint angle)	< +/- 1.5° (at T <sub>0</sub> = +23 °C)
Key LED figures	Normative reference	EN 62471:2008-09   IEC 62471:2006, modified
	LED risk group marking	Free group
	Wave length	635 nm
	Average service life	100,000 h at T <sub>a</sub> = +25 °C
Smallest detectable object (MDO) typ.		

		1 mm, At 50 mm distance (object with 90% remission (complies with standard white according to DIN 5033))
Adjustment	Teach-Turn adjustment	BluePilot For setting the sensing range
Display	LED blue	BluePilot: sensing range indicator
	LED green	Operating indicator Static on: power on
	LED yellow	Status of received light beam Static on: object present Static off: object not present
Special applications		Detecting flat objects, Detecting objects wrapped in film, Detecting perforated objects, Detecting un-even, shiny objects

## SAFETY-RELATED PARAMETERS

MTTF <sub>D</sub>	1,439 years
DC <sub>avg</sub>	0 %
T <sub>M</sub> (mission time)	20 years

## ELECTRONICS

Supply voltage U <sub>B</sub>	10 V DC ... 30 V DC <sup>1)</sup>																		
Ripple	≤ 5 V <sub>pp</sub>																		
Usage category	DC-12 (According to EN 60947-5-2) DC-13 (According to EN 60947-5-2)																		
Current consumption	≤ 25 mA, without load. At U <sub>B</sub> = 24 V																		
Protection class	III																		
Digital output	<table border="0"> <tr> <td>Number</td> <td>1</td> </tr> <tr> <td>Type</td> <td>PNP</td> </tr> <tr> <td>Switching mode</td> <td>Light switching</td> </tr> <tr> <td>Signal voltage PNP HIGH/LOW</td> <td>Approx. U<sub>B</sub> - 2.5 V / 0 V</td> </tr> <tr> <td>Output current I<sub>max</sub></td> <td>≤ 100 mA</td> </tr> <tr> <td>Circuit protection outputs</td> <td>Reverse polarity protected Overcurrent protected Short-circuit protected</td> </tr> <tr> <td>Response time</td> <td>≤ 1,000 μs<sup>2)</sup></td> </tr> <tr> <td>Repeatability (response time)</td> <td>240 μs</td> </tr> <tr> <td>Switching frequency</td> <td>500 Hz<sup>3)</sup></td> </tr> </table>	Number	1	Type	PNP	Switching mode	Light switching	Signal voltage PNP HIGH/LOW	Approx. U <sub>B</sub> - 2.5 V / 0 V	Output current I <sub>max</sub>	≤ 100 mA	Circuit protection outputs	Reverse polarity protected Overcurrent protected Short-circuit protected	Response time	≤ 1,000 μs <sup>2)</sup>	Repeatability (response time)	240 μs	Switching frequency	500 Hz <sup>3)</sup>
Number	1																		
Type	PNP																		
Switching mode	Light switching																		
Signal voltage PNP HIGH/LOW	Approx. U <sub>B</sub> - 2.5 V / 0 V																		
Output current I <sub>max</sub>	≤ 100 mA																		
Circuit protection outputs	Reverse polarity protected Overcurrent protected Short-circuit protected																		
Response time	≤ 1,000 μs <sup>2)</sup>																		
Repeatability (response time)	240 μs																		
Switching frequency	500 Hz <sup>3)</sup>																		
Pin/Wire assignment	<table border="0"> <tr> <td>Function of pin 4/black (BK)</td> <td>Digital output, light switching, object present → output Q HIGH</td> </tr> </table>	Function of pin 4/black (BK)	Digital output, light switching, object present → output Q HIGH																
Function of pin 4/black (BK)	Digital output, light switching, object present → output Q HIGH																		

<sup>1)</sup> Limit values.

<sup>2)</sup> Signal transit time with resistive load in switching mode.

<sup>3)</sup> With light/dark ratio 1:1.

## MECHANICS

Housing	Rectangular						
Design detail	Flat						
Dimensions (W x H x D)	16 mm x 40.1 mm x 12.1 mm						
Connection	Cable with plug M8, 3-pin, with knurled nut, 338 mm						
Connection detail	<table border="0"> <tr> <td>Deep-freeze property</td> <td>Do not bend below 0 °C</td> </tr> <tr> <td>Conductor size</td> <td>0.14 mm<sup>2</sup></td> </tr> <tr> <td>Cable diameter</td> <td>Ø 3.4 mm</td> </tr> </table>	Deep-freeze property	Do not bend below 0 °C	Conductor size	0.14 mm <sup>2</sup>	Cable diameter	Ø 3.4 mm
Deep-freeze property	Do not bend below 0 °C						
Conductor size	0.14 mm <sup>2</sup>						
Cable diameter	Ø 3.4 mm						

	Length of cable (L)	300 mm
Material	Housing	Plastic, VISTAL®
	Front screen	Plastic, PMMA
	Cable	Plastic, PVC
	Male connector	Plastic, VISTAL®
Weight		Approx. 30 g
Maximum tightening torque of the fixing screws		0.4 Nm

### AMBIENT DATA

Enclosure rating	IP66 (EN 60529) IP67 (EN 60529)
Ambient operating temperature	-40 °C ... +60 °C
Ambient temperature, storage	-40 °C ... +75 °C
Typ. Ambient light immunity	Artificial light: ≤ 50,000 lx Sunlight: ≤ 50,000 lx
Shock resistance	30 g, 11 ms (3 positive and 3 negative shocks along X, Y, Z axes, 18 total shocks (EN60068-2-27))
Vibration resistance	10 Hz ... 1,000 Hz (Amplitude 1 mm, 3 x 30 min (EN60068-2-6))
Air humidity	35 % ... 95 %, relative humidity (no condensation)
Electromagnetic compatibility (EMC)	EN 60947-5-2
Resistance to cleaning agent	ECOLAB
UL File No.	NRKH.E181493 & NRKH7.E181493

### CERTIFICATES

EU declaration of conformity	✓
UK declaration of conformity	✓
ACMA declaration of conformity	✓
Moroccan declaration of conformity	✓
China RoHS	✓
ECOLAB certificate	✓
cULus certificate	✓

### DISPLAY AND ADJUSTMENT ELEMENTS

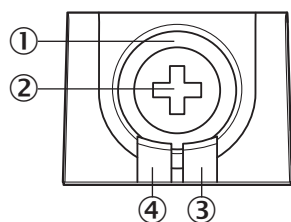

- ① LED blue
- ② Teach-Turn adjustment
- ③ LED yellow
- ④ LED green

### CONNECTION TYPE CONNECTOR M8, 3-PIN

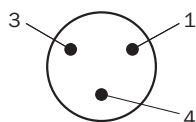

CONNECTION DIAGRAM CD-045

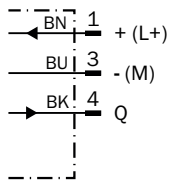

TRUTH TABLE PUSH-PULL: PNP/NPN - LIGHT SWITCHING Q

	Light switching Q (normally open (upper switch), normally closed (lower switch))	
	Object not present → Output LOW	Object present → Output HIGH
Light receive	✘	✔
Light receive indicator	✘	☀
Load resistance to L+	⚡	✘
Load resistance to M	✘	⚡

**TRUTH TABLE PUSH-PULL: PNP/NPN - DARK SWITCHING  $\bar{Q}$**

	Dark switching $\bar{Q}$ (normally closed (upper switch), normally open (lower switch))	
	Object not present → Output HIGH	Object present → Output LOW
Light receive	⊗	✓
Light receive indicator	⊗	☀
Load resistance to L+	⊗	⚡
Load resistance to M	⚡	⊗

**CHARACTERISTIC CURVE**

Minimum distance in mm (y) between the set sensing range and white background (90 % remission)

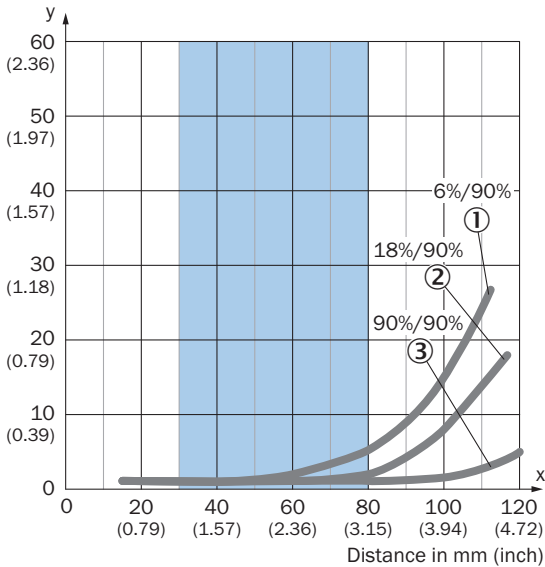

Example:  
Safe suppression of the background

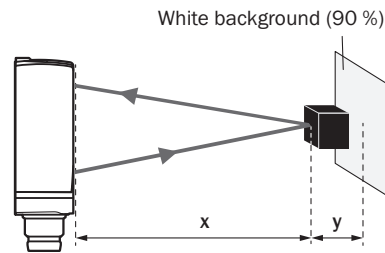

Black object (6 % remission)  
Set sensing range  $x = 80$  mm  
Needed minimum distance to white background  $y = 5$  mm

Recommended sensing range for the best performance

- ① Black object, 6% remission factor
- ② Gray object, 18% remission factor
- ③ White object, 90% remission factor

**LIGHT SPOT SIZE VERTICAL**

Dimensions in mm (inch)

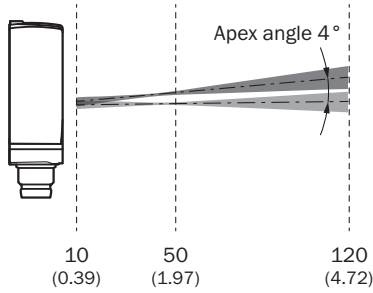
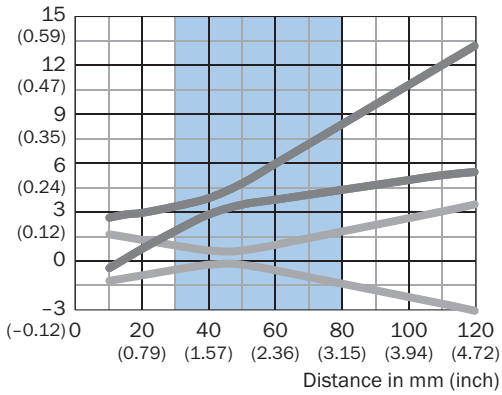

Recommended sensing range for the best performance

**LIGHT SPOT SIZE HORIZONTAL**

Dimensions in mm (inch)

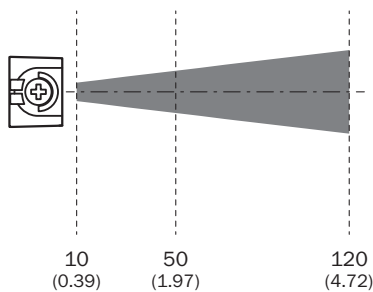
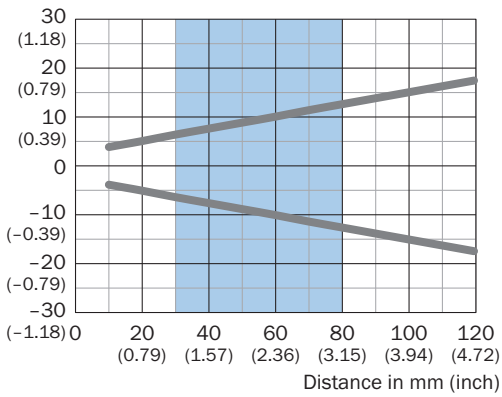

Recommended sensing range for the best performance

**SENSING RANGE DIAGRAM**

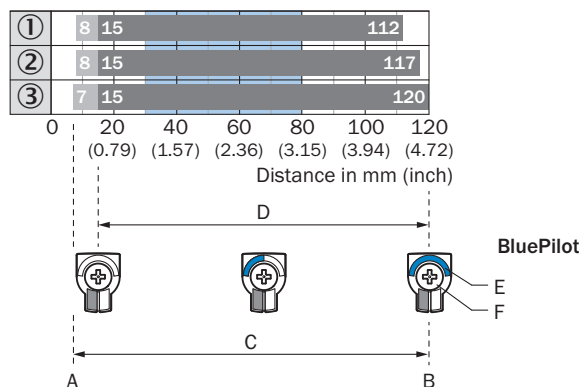

A = Sensing range min. in mm

B = Sensing range max. in mm

C = Viewing range

D = Adjustable switching threshold for background suppression

E = Sensing range indicator

F = Teach-Turn adjustment

■ Recommended sensing range for the best performance

① Black object, 6% remission factor

② Gray object, 18% remission factor

③ White object, 90% remission factor

**DIMENSIONAL DRAWING**

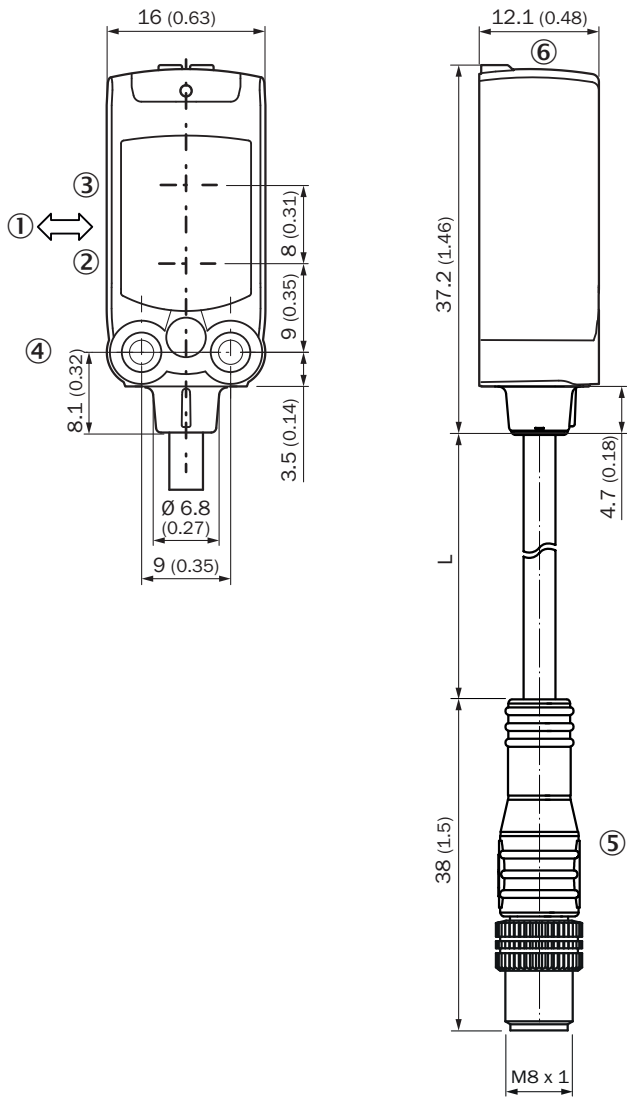

Dimensions in mm (inch)

For length of cable (L), see technical data

- ① Standard direction of the material being detected
- ② Center of optical axis, sender
- ③ Center of optical axis, receiver
- ④ M3 mounting hole
- ⑤ Cable with plug M8, with knurled nut
- ⑥ display and adjustment elements

Further information as well as suitable accessories, example applications and downloads such as CAD dimensional models, operating instructions and software can be found at [www.sick.com/1148339](http://www.sick.com/1148339)



SICK AG  
WALDKIRCH  
GERMANY  
SICK.COM

# SICK AT A GLANCE

SICK is a leading global technology company for intelligent sensors and integrated solutions in industrial automation. Our technologies set benchmarks, making your industrial processes more efficient, safer and more sustainable – both in logistics and manufacturing operations.

SICK combines sensor intelligence with industry expertise and certified consulting services. We provide the ideal foundation for scalable as well as tailor-made automation solutions and create added value along the entire value chain. Our close partnerships with our customers are more than just a promise: Together, we optimize productivity, improve quality, protect health and safety, and help build a sustainable future. All with empathy and trust.

Since 1946, we have been developing innovative technologies with passion and a pioneering spirit. With a global network in around 40 countries, SICK has a global presence and is always close by. The company's headquarters are located in Waldkirch near Freiburg, Germany. Our customers benefit from our understanding of both local and global requirements, which enables us to deliver tailor-made solutions

**SICK**  
Sensor Intelligence