



# PLOC2D-8305-8

PLOC2D

ROBOT GUIDANCE SYSTEMS

**SICK**  
Sensor Intelligence.



### Ordering information

Type	part no.
PLOC2D-8305-8	1147086

Other models and accessories → [www.sick.com/PLOC2D](http://www.sick.com/PLOC2D)



### Detailed technical data

#### Features

<b>Product name</b>	PLOC2D-FIX0020
<b>System features</b>	Stand-alone sensor with easy teach, for localization of parts using 2D measurements
<b>Example field of view</b>	For details see field of view diagram
<b>Working distance</b>	200 mm ... 2,500 mm
<b>Light source</b>	Internal lighting LED, white, Visible, 6,500 K, ± 1,000 K
<b>Optical focus</b>	Adjustable focus (manually)
<b>LED class</b>	Risk group 1 (low risk, IEC 62471 (2006-07) / EN 62471 (2008-09))
<b>Localization principle</b>	Shape comparison
<b>Sensor resolution</b>	2,464 px x 2,048 px (5.1 MP)
<b>Lens</b>	C-mount
<b>Focal length</b>	8 mm
<b>Technology</b>	2D snapshot, image analysis
<b>Description</b>	High resolution 2D localization of parts in medium/large fields of view at medium/long reading distances

#### Mechanics/electronics

<b>Connection type</b>	1 x M12, 17-pin male connector, A-coded (Power, I/O) 1 x M8, 4-pin female connector (external illumination) 1 x M12, 8-pin female connector, X-coded (Gigabit Ethernet) 2 x M12, 4-pin female connector, D-coded (fieldbus Ethernet)
<b>Supply voltage</b>	24 V DC, ± 20 %
<b>Power consumption</b>	21 W
<b>Housing material</b>	Aluminum die cast
<b>Window material</b>	PMMA
<b>Dimensions (L x W x H)</b>	63 mm x 85 mm x 108 mm
<b>Weight</b>	545 g, without lens
<b>Enclosure rating</b>	IP65

## Performance

<b>Part localization time</b>	140 ms for the first part in the image, < 60 ms for additional parts in the image (typical)
<b>Localization accuracy</b>	± 0.5 px, ± 0.1°
<b>Output data</b>	X, Y (mm), rotation around Z (degrees)

## Interfaces

<b>Ethernet</b>	✓
Data transmission rate	100 Mbit/s
Protocol	TCP/IP XML and CSV (robot), TCP/IP (operator)
Electrical connection	M12 socket, 8-pin, X-coded
<b>Supply voltage</b>	
Electrical connection	Male connector M12, 17-pin
<b>User interface</b>	Web server
<b>Data storage and retrieval</b>	Image and data logging via microSD memory card and external FTP

## Ambient data

<b>Ambient temperature, operation</b>	0 °C ... +40 °C, permissible relative humidity: 0% ... 90% (non-condensing)
<b>Ambient temperature, storage</b>	-20 °C ... +70 °C <sup>1)</sup>
<b>Shock load</b>	EN 60068-2-6:2007, EN 60068-2-64:2019
<b>Vibration load</b>	EN 60068-2-6:2008-02

<sup>1)</sup> Permissible relative humidity: 0% ... 90% (non-condensing).

## General notes

<b>Items supplied</b>	Camera, complete with integrated optics and illumination unit as well as installed PLOC2D software app
-----------------------	--

## Certificates

<b>EU declaration of conformity</b>	✓
<b>UK declaration of conformity</b>	✓
<b>ACMA declaration of conformity</b>	✓
<b>China RoHS</b>	✓
<b>cULus certificate</b>	✓
<b>Profinet certificate</b>	✓
<b>Ethernet/IP certificate</b>	✓
<b>Information according to Art. 3 of Data Act (Regulation EU 2023/2854)</b>	✓

## Classifications

<b>ECLASS 5.0</b>	27381501
<b>ECLASS 5.1.4</b>	27381501
<b>ECLASS 6.0</b>	27381590
<b>ECLASS 6.2</b>	27381590
<b>ECLASS 7.0</b>	27381590
<b>ECLASS 8.0</b>	27381590
<b>ECLASS 8.1</b>	27381590

<b>ECLASS 9.0</b>	27381590
<b>ECLASS 10.0</b>	27381590
<b>ECLASS 11.0</b>	27381591
<b>ECLASS 12.0</b>	27381591

Dimensional drawing Structure and device dimensions, unit: mm (inch), decimal separator: period

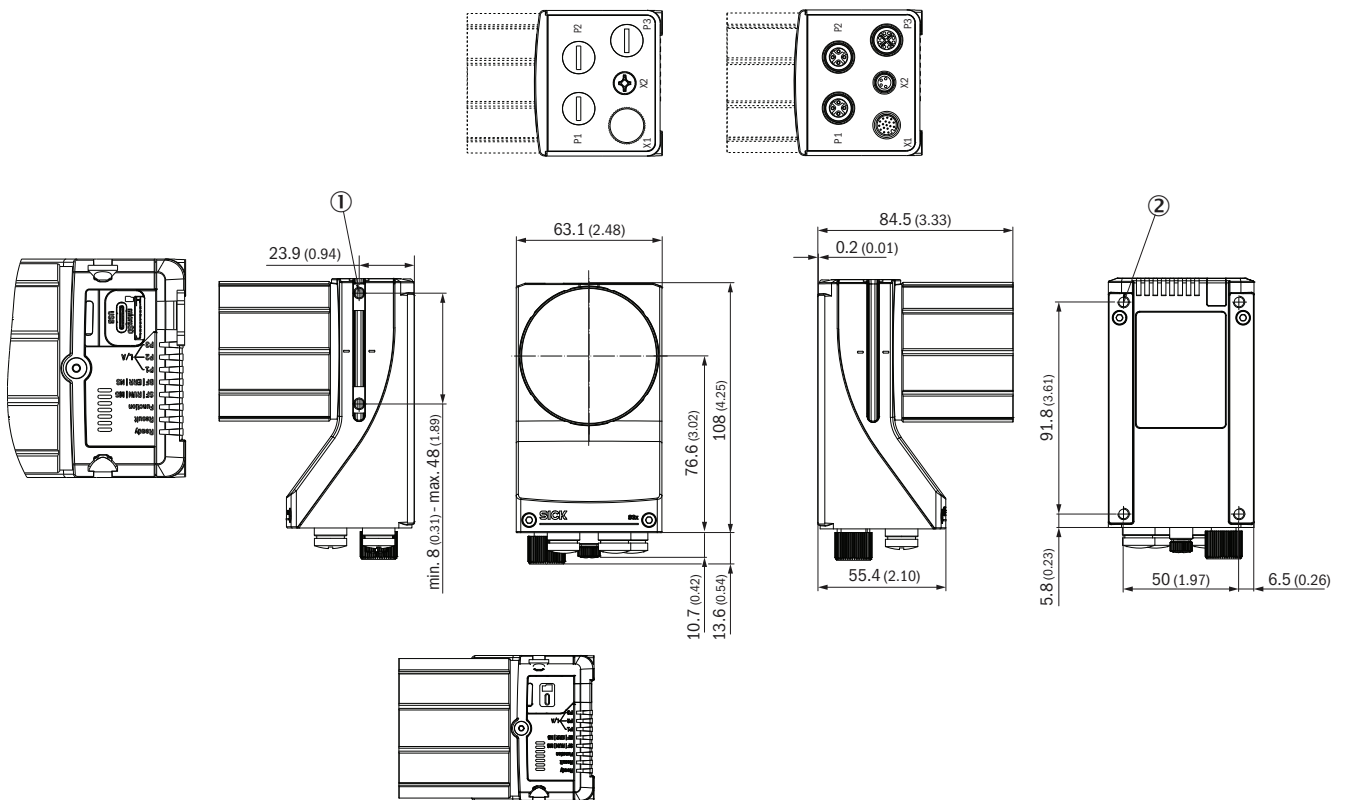

Dimensions in mm (inch)

- ① 2 M5 sliding nuts; 5.5 mm deep; pivoting; as an alternative method of mounting the product
- ② 4 tapped blind holes, M5, 5.5 mm deep for mounting the product

### Characteristic curve V2D8301P/V2D8305P

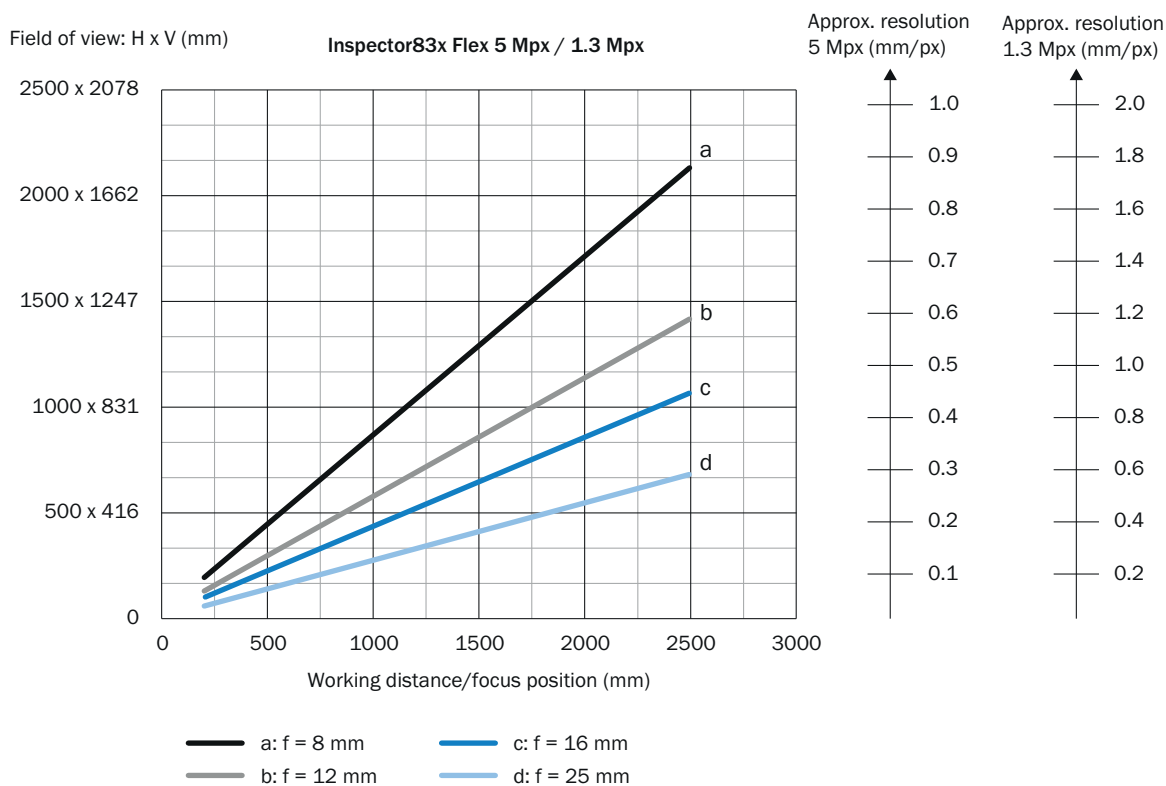

- ① Field of view: Horizontal x vertical in mm
- ② approximate resolution in mm/px
- ③ Working distance/Focus position in mm

### Recommended accessories

Other models and accessories → [www.sick.com/PLOC2D](http://www.sick.com/PLOC2D)

	Brief description	Type	part no.
Commissioning aids and test equipment			
	<ul style="list-style-type: none"> <li>• <b>Product:</b> Test equipment</li> <li>• <b>Description:</b> Target for alignment and calibration, A3-size</li> </ul>	PLOC2D alignment and calibration target A3	4092645

## SICK AT A GLANCE

SICK is one of the leading manufacturers of intelligent sensors and sensor solutions for industrial applications. A unique range of products and services creates the perfect basis for controlling processes securely and efficiently, protecting individuals from accidents and preventing damage to the environment.

We have extensive experience in a wide range of industries and understand their processes and requirements. With intelligent sensors, we can deliver exactly what our customers need. In application centers in Europe, Asia and North America, system solutions are tested and optimized in accordance with customer specifications. All this makes us a reliable supplier and development partner.

Comprehensive services complete our offering: SICK LifeTime Services provide support throughout the machine life cycle and ensure safety and productivity.

For us, that is “Sensor Intelligence.”

## WORLDWIDE PRESENCE:

Contacts and other locations –[www.sick.com](http://www.sick.com)