



V2D8301P-1MCICXAF1SXXXX

Inspector83x

2D MACHINE VISION

SICK
Sensor Intelligence.



Ordering information

Type	part no.
V2D8301P-1MCICXAF1SXXXX	1144810

Other models and accessories → www.sick.com/Inspector83x



Detailed technical data

Features

Technology	2D snapshot
Programmable	✓
Configurable	✓
Application software	Nova Inspector
License included	Intelligent Inspection License
Expansion options	The SICK Nova Tool plug-in enables customer-specific or new tools to be added. Development and customization of the tools is supported by SICK AppSpace and SICK AppStudio.
License type	The software is provided as a device license. A license is bound to a specific hardware ID.
License period	The license is issued without a time limit.
Toolkit	SICK algorithm API HALCON
Image sensor	CMOS monochrome
Shutter technology	Global-Shutter
Optical focus	Adjustable focus (manual)
Working range	200 mm ... 2,500 mm, depends on lens used ¹⁾
Illumination	Integrated
Illumination color	White, LED, Visible, 6,500 K, ± 1,000 K
LED class	Risk group 1 (IEC 62471 (2006-07) / EN 62471 (2008-09))
Lens	C-mount
	Optical format
	Focal length
Task	Detecting - Standard objects Measuring - Dimension, contour and volume Measuring - Number Identifying - 2D code Identifying - OCR Identifying - Pattern

¹⁾ For details see field of view diagram.

Identifying - Classifying
 Identifying - Sorting
 Determining position - 2D position determination

¹⁾ For details see field of view diagram.

Mechanics/electronics

Connection type	1 x M12, 17-pin male connector, A-coded (Power, I/O) 1 x M8, 4-pin female connector (external illumination) 1 x M12, 8-pin female connector, X-coded (Gigabit Ethernet) 2 x M12, 4-pin female connector, D-coded (fieldbus Ethernet)
Supply voltage	24 V DC, $\pm 20\%$ ¹⁾
Power consumption	21 W ²⁾
Enclosure rating	IP65 (IEC 60529:2013 +C1:2013 +C2:2015 +AMD2 C1:2019, EN 60529:1991 +A1:2010 +A2:2013 +AC:2019-02)
Housing material	Aluminum die cast
Window material	Plastic (PMMA), 2 mm thick, with scratch-proof, anti-reflection (AR) coating on both sides
Weight	545 g, without lens and connection cables
Dimensions (L x W x H)	108 mm x 63.1 mm x 84.5 mm
MTBF	100,000 h ³⁾

¹⁾ Voltage source in accordance with ES1 (EN 62368-1) or SELV (EN 60950-1).

²⁾ For digital outputs without load.

³⁾ At 25 °C ambient operating temperature.

Performance

Sensor properties	
Sensor resolution	1,232 px x 1,024 px (1.3 MP)
Pixel size	5.48 μm x 5.48 μm
Sensor size	6.75 mm x 5.61 mm
Scan/frame rate	60 Hz ¹⁾

¹⁾ Maximum, lower at long exposure times. Image capture time only, does not include additional required processing time.

Interfaces

Ethernet	✓, TCP/IP
Function	FTP
Data transmission rate	10/100/1,000 Mbit/s, MAC address (device-specific), see type label
EtherNet/IP™	✓
Function	EtherNet/IP™ Dual Port
Data transmission rate	10/100 MBit/s
PROFINET	✓
Function	PROFINET Dual Port
Data transmission rate	10/100 MBit/s
Operator interfaces	Web server
Configuration software	Web GUI (SensorApp configuration), SICK AppManager (IP determination and configuration, SensorApp installation), SICK AppStudio (programming)
Data storage and retrieval	Image and data logging via external FTP
Inputs/outputs	2 x opto-decoupled inputs, physical, switching

	6 x configurable input/output, physical, switching (4 on the Power-I/O connection, 2 on the external illumination connection)
Output current	≤ 50 mA
Maximum encoder frequency	Max. 50 kHz
External illumination	External voltage supply or via Vout (max. 1 A) at the X2 4-pin female connector as an illumination connection. Trigger via digital output via X1 17-pin male connector or via external illumination connection at the X2 4-pin female connector.
Optical indicators	8 status LEDs

Ambient data

Vibration resistance	EN 60068-2-6:2007, EN 60068-2-64:2019
Shock resistance	EN 60068-2-27:2008
Ambient operating temperature	0 °C ... +40 °C ¹⁾
Storage temperature	-20 °C ... +70 °C
Relative humidity	≤ 90 %, Non-condensing
Altitude (above sea level)	< 5,000 m

¹⁾ If the ambient operating temperature will be ≥ 45 °C, ensure adequate heat dissipation when mounting the device.

Licenses

License included	Intelligent Inspection License
Expansion options	The SICK Nova Tool plug-in enables customer-specific or new tools to be added. Development and customization of the tools is supported by SICK AppSpace and SICK AppStudio.

Certificates

EU declaration of conformity	✓
UK declaration of conformity	✓
ACMA declaration of conformity	✓
China RoHS	✓
cULus certificate	✓
Profinet certificate	✓
Ethernet/IP certificate	✓
Information according to Art. 3 of Data Act (Regulation EU 2023/2854)	✓

Classifications

ECLASS 5.0	27310205
ECLASS 5.1.4	27310205
ECLASS 6.0	27310205
ECLASS 6.2	27310205
ECLASS 7.0	27310205
ECLASS 8.0	27310205
ECLASS 8.1	27310205
ECLASS 9.0	27310205
ECLASS 10.0	27310205
ECLASS 11.0	27310205
ECLASS 12.0	27310205

ETIM 5.0	EC001820
ETIM 6.0	EC001820
ETIM 7.0	EC001820
ETIM 8.0	EC001820
UNSPSC 16.0901	43211731

Dimensional drawing Structure and device dimensions, unit: mm (inch), decimal separator: period

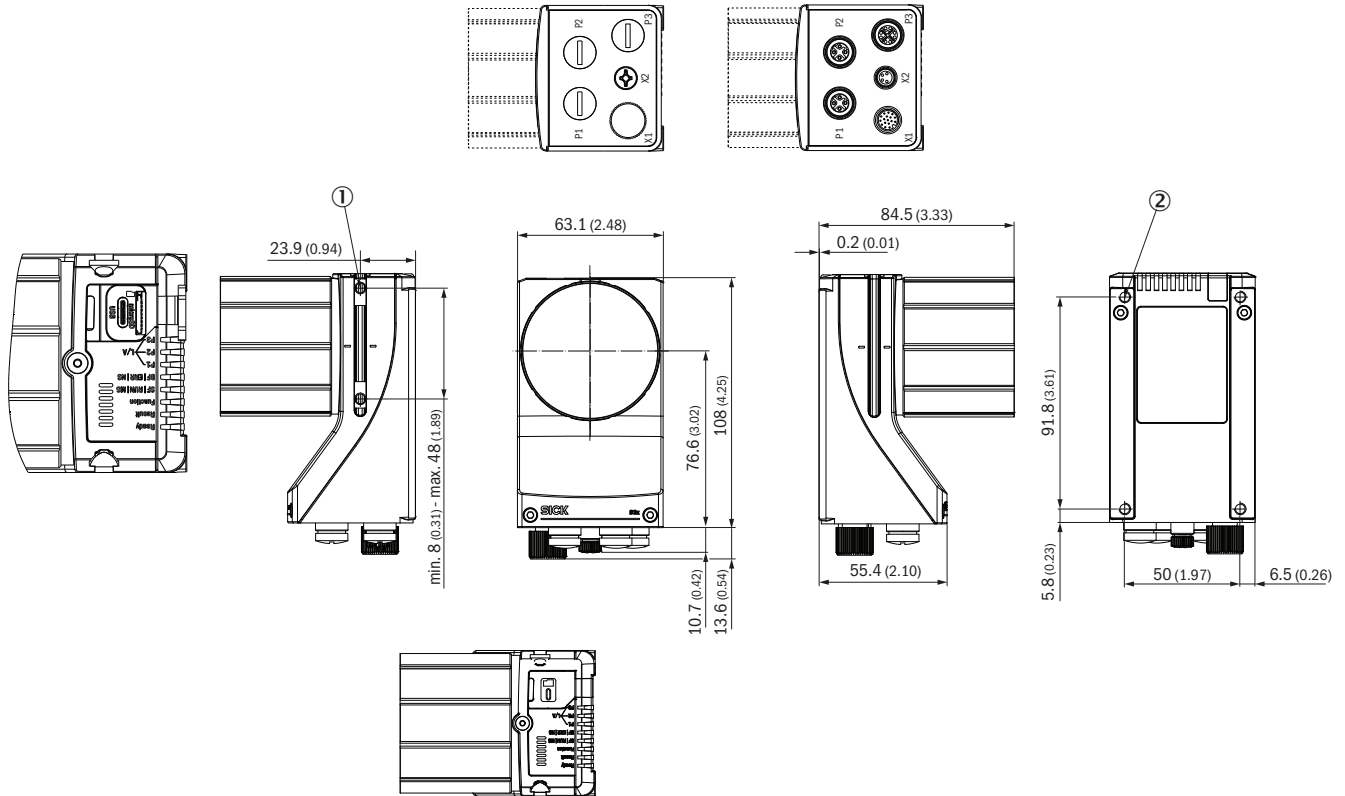

Dimensions in mm (inch)

- ① 2 M5 sliding nuts; 5.5 mm deep; pivoting; as an alternative method of mounting the product
- ② 4 tapped blind holes, M5, 5.5 mm deep for mounting the product

Field of view V2D8301P

Field of view: H x V (mm) ①

Inspector83x Flex 1.3 Mpx

Approx. resolution (mm/px) ②

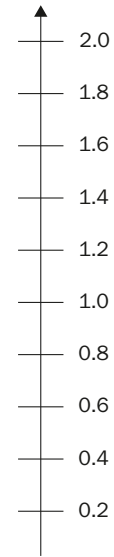

- a: f = 8 mm
- b: f = 12 mm
- c: f = 16 mm
- d: f = 25 mm

- ① Field of view: Horizontal x vertical in mm
- ② approximate resolution in mm/px
- ③ Working distance/Focus position in mm



Field of view V2D8301P/V2D8305P



- ① Field of view: Horizontal x vertical in mm
- ② approximate resolution in mm/px
- ③ Working distance/Focus position in mm

Recommended accessories

Other models and accessories → www.sick.com/Inspector83x

	Brief description	Type	part no.
connectors and cables			
	<ul style="list-style-type: none"> • Connection type head A: Male connector, M12, 8-pin, straight, X-coded • Connection type head B: Male connector, RJ45, 8-pin, straight • Signal type: Ethernet, Gigabit Ethernet • Cable: 5 m, 8-wire, PUR, halogen-free • Description: Ethernet, shielded, Gigabit Ethernet • Application: Zones with oils and lubricants 	YM2X18-050EG1M-RJA8	2106259
	<ul style="list-style-type: none"> • Connection type head A: Female connector, M12, 17-pin, straight, A-coded • Connection type head B: Male connector, M12, 17-pin, straight, A-coded • Signal type: Power, serial, CAN, digital I/Os • Cable: 3 m, 17-wire • Description: Power, suitable for 2 A, shielded, Serial, CAN, Digital I/Os • Application: Drag chain operation 	YM2A8D-030XXXF2A8D	6051194
	<ul style="list-style-type: none"> • Connection type head A: Male connector, USB-C, 4-pin, straight • Connection type head B: Male connector, USB-A, 4-pin, straight • Cable: 2 m, PVC 	YMUSA4-020VG5MUSC4	2119989

	Brief description	Type	part no.
Junction boxes			
		CDB650-204	1064114

SICK AT A GLANCE

SICK is one of the leading manufacturers of intelligent sensors and sensor solutions for industrial applications. A unique range of products and services creates the perfect basis for controlling processes securely and efficiently, protecting individuals from accidents and preventing damage to the environment.

We have extensive experience in a wide range of industries and understand their processes and requirements. With intelligent sensors, we can deliver exactly what our customers need. In application centers in Europe, Asia and North America, system solutions are tested and optimized in accordance with customer specifications. All this makes us a reliable supplier and development partner.

Comprehensive services complete our offering: SICK LifeTime Services provide support throughout the machine life cycle and ensure safety and productivity.

For us, that is “Sensor Intelligence.”

WORLDWIDE PRESENCE:

Contacts and other locations –www.sick.com