



# V2D8305P-1CCIBXAF1SXXXX

Inspector83x

2D MACHINE VISION

**SICK**  
Sensor Intelligence.



### Ordering information

Type	part no.
V2D8305P-1CCIBXAF1SXXX	1144163

Other models and accessories → [www.sick.com/Inspector83x](http://www.sick.com/Inspector83x)



### Detailed technical data

#### Features

<b>Technology</b>	2D snapshot
<b>Programmable</b>	✓
<b>Configurable</b>	✓
<b>Application software</b>	Nova Inspector
<b>License included</b>	Quality Inspection License
<b>Expansion options</b>	The SICK Nova Tool plug-in enables customer-specific or new tools to be added. Development and customization of the tools is supported by SICK AppSpace and SICK AppStudio.
<b>Toolkit</b>	SICK algorithm API HALCON
<b>Image sensor</b>	CMOS Color
<b>Shutter technology</b>	Global-Shutter
<b>Optical focus</b>	Adjustable focus (manual)
<b>Working range</b>	200 mm ... 2,500 mm, depends on lens used <sup>1)</sup>
<b>Illumination</b>	Integrated
<b>Illumination color</b>	White, LED, Visible, 6,500 K, ± 1,000 K
<b>LED class</b>	Risk group 1 (IEC 62471 (2006-07) / EN 62471 (2008-09))
<b>Lens</b>	C-mount
	Optical format 1/1.8"
	Focal length 8 mm
<b>Task</b>	Detecting - Standard objects Measuring - Dimension, contour and volume Measuring - Number Identifying - 2D code Identifying - OCR Identifying - Pattern Identifying - Classifying Identifying - Sorting Determining position - 2D position determination

<sup>1)</sup> For details see field of view diagram.

## Mechanics/electronics

<b>Supply voltage</b>	24 V DC, $\pm 20\%$ <sup>1)</sup>
<b>Power consumption</b>	21 W <sup>2)</sup>
<b>Enclosure rating</b>	IP65 (IEC 60529:2013 +C1:2013 +C2:2015 +AMD2 C1:2019, EN 60529:1991 +A1:2010 +A2:2013 +AC:2019-02)
<b>Housing material</b>	Aluminum die cast
<b>Window material</b>	Plastic (PMMA), 2 mm thick, with scratch-proof, anti-reflection (AR) coating on both sides
<b>Weight</b>	545 g, without lens and connection cables
<b>MTBF</b>	100,000 h <sup>3)</sup>

<sup>1)</sup> Voltage source in accordance with ES1 (EN 62368-1) or SELV (EN 60950-1).

<sup>2)</sup> For digital outputs without load.

<sup>3)</sup> At 25 °C ambient operating temperature.

## Performance

<b>Sensor properties</b>	
Sensor resolution	2,464 px x 2,048 px (5.1 MP)
Pixel size	2.74 $\mu\text{m}$ x 2.74 $\mu\text{m}$
Sensor size	6.75 mm x 5.61 mm
<b>Scan/frame rate</b>	30 Hz <sup>1)</sup>

<sup>1)</sup> Maximum, lower at long exposure times. Image capture time only, does not include additional required processing time.

## Interfaces

<b>Ethernet</b>	✓, TCP/IP, UDP
Function	FTP, HTTP, HTTPS, NTP
Data transmission rate	10/100/1,000 Mbit/s, MAC address (device-specific), see type label
<b>EtherNet/IP™</b>	✓
Function	EtherNet/IP™ Dual Port
Data transmission rate	10/100 MBit/s
<b>PROFINET</b>	✓
Function	PROFINET Dual Port
Data transmission rate	10/100 MBit/s
<b>Serial</b>	✓, RS-232, RS-422
Data transmission rate	300 Baud ... 115.2 Baud
<b>Operator interfaces</b>	Web server
<b>Configuration software</b>	Web GUI (SensorApp configuration), SICK AppManager (IP determination and configuration, SensorApp installation), SICK AppStudio (programming)
<b>Data storage and retrieval</b>	Image and data logging via microSD memory card and external FTP
<b>Inputs/outputs</b>	2 x opto-decoupled inputs, physical, switching 6 x configurable input/output, physical, switching (4 on the Power-I/O connection, 2 on the external illumination connection)
<b>Output current</b>	$\leq 50$ mA
<b>Maximum encoder frequency</b>	Max. 50 kHz
<b>External illumination</b>	External voltage supply or via Vout (max. 1 A) at the X2 4-pin female connector as an illumination connection. Trigger via digital output via X1 17-pin male connector or via external illumination connection at the X2 4-pin female connector.
<b>Optical indicators</b>	8 status LEDs

### Ambient data

<b>Vibration resistance</b>	EN 60068-2-6:2007, EN 60068-2-64:2019
<b>Shock resistance</b>	EN 60068-2-27:2008
<b>Ambient operating temperature</b>	0 °C ... +40 °C <sup>1)</sup>
<b>Storage temperature</b>	-20 °C ... +70 °C
<b>Relative humidity</b>	≤ 90 %, Non-condensing
<b>Altitude (above sea level)</b>	< 5,000 m

<sup>1)</sup> If the ambient operating temperature will be ≥ 45 °C, ensure adequate heat dissipation when mounting the device.

### Licenses

<b>License included</b>	Quality Inspection License
<b>Product type</b>	Software
<b>License type</b>	Device license
<b>License description</b>	The Quality Inspection license enables productive use of a large subset of the tools of a SICK Nova SensorApp. The Quality Inspection toolkit is used to ensure that products comply with exact requirements after production, for instance when it comes to dimensions and angular degrees. The software is provided as a device license. A license is bound to a specific hardware ID.
<b>Function range</b>	Full version
<b>License period</b>	The license is issued without a time limit.
<b>Expansion options</b>	The SICK Nova Tool plug-in enables customer-specific or new tools to be added. Development and customization of the tools is supported by SICK AppSpace and SICK AppStudio. Optional upgrade with the Intelligent Inspection Upgrade License, which enables productive use of the complete toolset.

### Certificates

<b>EU declaration of conformity</b>	✓
<b>UK declaration of conformity</b>	✓
<b>ACMA declaration of conformity</b>	✓
<b>China RoHS</b>	✓
<b>cULus certificate</b>	✓
<b>Profinet certificate</b>	✓
<b>Ethernet/IP certificate</b>	✓
<b>Information according to Art. 3 of Data Act (Regulation EU 2023/2854)</b>	✓

### Classifications

<b>ECLASS 5.0</b>	27310205
<b>ECLASS 5.1.4</b>	27310205
<b>ECLASS 6.0</b>	27310205
<b>ECLASS 6.2</b>	27310205
<b>ECLASS 7.0</b>	27310205
<b>ECLASS 8.0</b>	27310205
<b>ECLASS 8.1</b>	27310205
<b>ECLASS 9.0</b>	27310205
<b>ECLASS 10.0</b>	27310205

<b>ECLASS 11.0</b>	27310205
<b>ECLASS 12.0</b>	27310205
<b>ETIM 5.0</b>	EC001820
<b>ETIM 6.0</b>	EC001820
<b>ETIM 7.0</b>	EC001820
<b>ETIM 8.0</b>	EC001820
<b>UNSPSC 16.0901</b>	43211731

Dimensional drawing Structure and device dimensions, unit: mm (inch), decimal separator: period

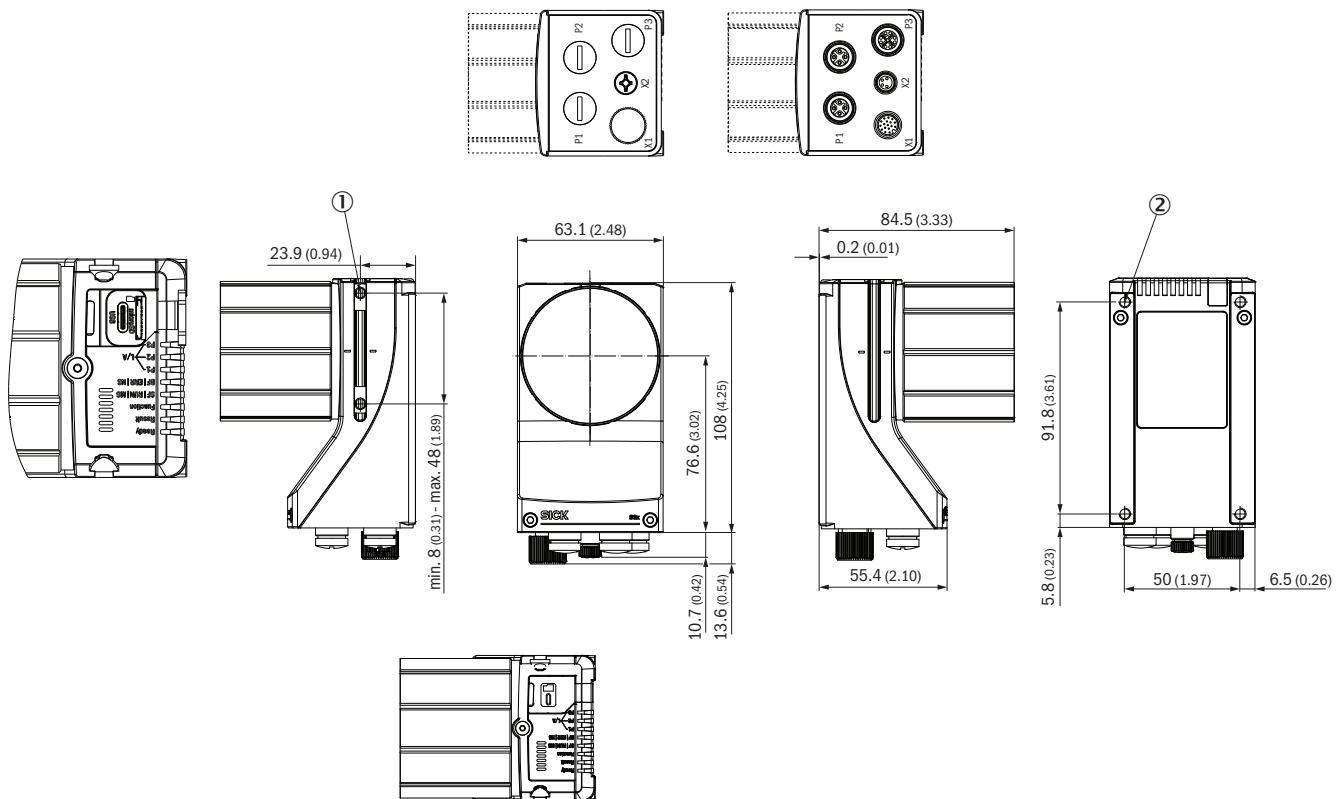

Dimensions in mm (inch)

- ① 2 M5 sliding nuts; 5.5 mm deep; pivoting; as an alternative method of mounting the product
- ② 4 tapped blind holes, M5, 5.5 mm deep for mounting the product

Field of view V2D8305P

Field of view: H x V (mm) ①

Inspector83x Flex 5 Mpx

Approx. resolution (mm/px) ②

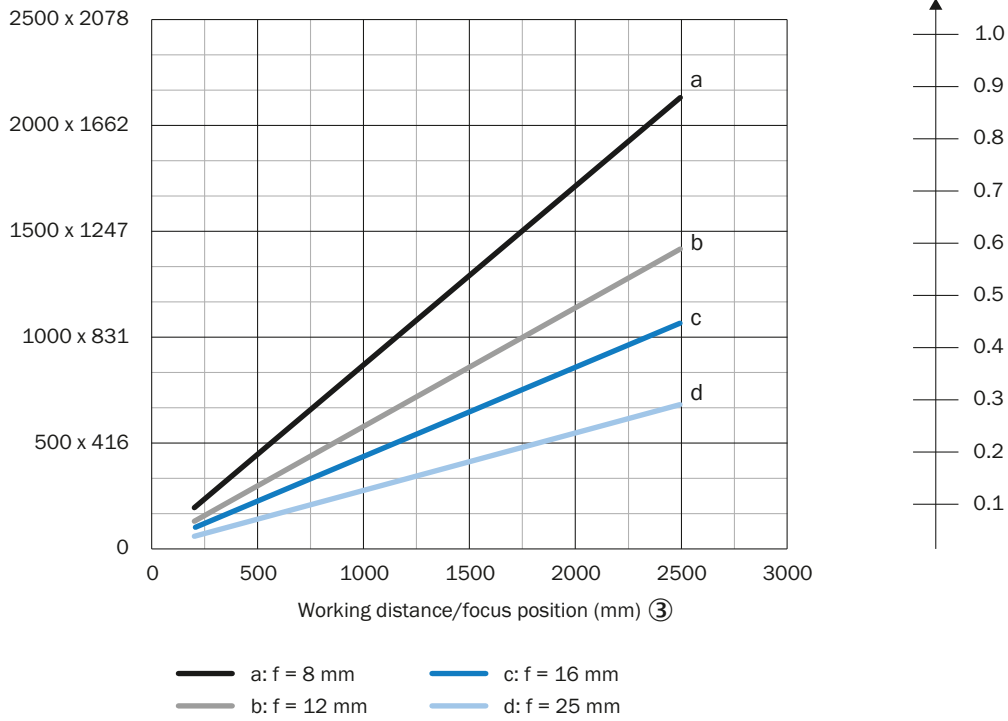

- ① Field of view: Horizontal x vertical in mm
- ② approximate resolution in mm/px
- ③ Working distance/Focus position in mm

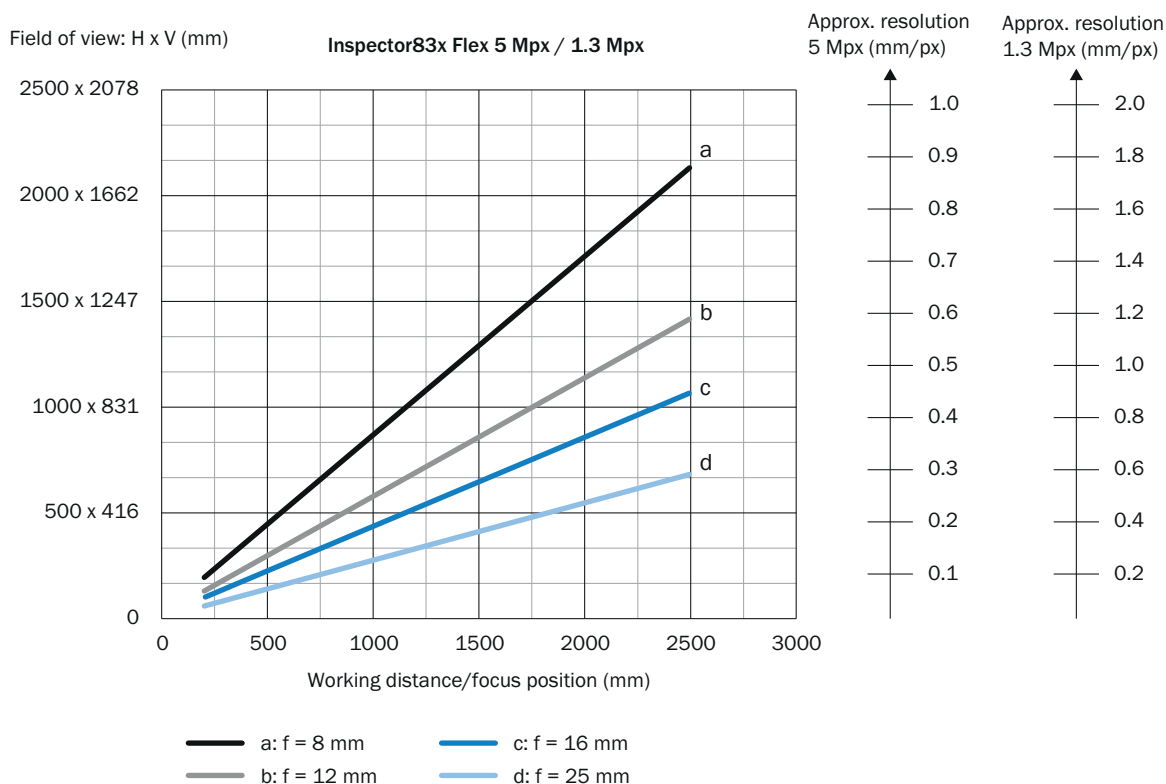

Field of view V2D8301P/V2D8305P



- ① Field of view: Horizontal x vertical in mm
- ② approximate resolution in mm/px
- ③ Working distance/Focus position in mm

Recommended accessories

Other models and accessories → [www.sick.com/Inspector83x](http://www.sick.com/Inspector83x)

	Brief description	Type	part no.
connectors and cables			
	<ul style="list-style-type: none"> <li>• <b>Connection type head A:</b> Male connector, M12, 8-pin, straight, X-coded</li> <li>• <b>Connection type head B:</b> Male connector, RJ45, 8-pin, straight</li> <li>• <b>Signal type:</b> Ethernet, Gigabit Ethernet</li> <li>• <b>Cable:</b> 5 m, 8-wire, PUR, halogen-free</li> <li>• <b>Description:</b> Ethernet, shielded, Gigabit Ethernet</li> <li>• <b>Application:</b> Zones with oils and lubricants</li> </ul>	YM2X18-050EG1M-RJA8	2106259
	<ul style="list-style-type: none"> <li>• <b>Description:</b> Power, suitable for 2 A, shielded, Serial, CAN, Digital I/Os</li> <li>• <b>Connection type head A:</b> Female connector, M12, 17-pin, straight, A-coded</li> <li>• <b>Connection type head B:</b> Male connector, M12, 17-pin, straight, A-coded</li> <li>• <b>Signal type:</b> Power, serial, CAN, digital I/Os</li> <li>• <b>Cable:</b> 3 m, 17-wire</li> <li>• <b>Application:</b> Drag chain operation</li> </ul>	YM2A8D-030XXF2A8D	6051194
	<ul style="list-style-type: none"> <li>• <b>Connection type head A:</b> Male connector, USB-C, 4-pin, straight</li> <li>• <b>Connection type head B:</b> Male connector, USB-A, 4-pin, straight</li> <li>• <b>Cable:</b> 2 m, PVC</li> </ul>	YMUSA4-020VG5MUSC4	2119989

	Brief description	Type	part no.
Junction boxes			
		CDB650-204	1064114

## SICK AT A GLANCE

SICK is one of the leading manufacturers of intelligent sensors and sensor solutions for industrial applications. A unique range of products and services creates the perfect basis for controlling processes securely and efficiently, protecting individuals from accidents and preventing damage to the environment.

We have extensive experience in a wide range of industries and understand their processes and requirements. With intelligent sensors, we can deliver exactly what our customers need. In application centers in Europe, Asia and North America, system solutions are tested and optimized in accordance with customer specifications. All this makes us a reliable supplier and development partner.

Comprehensive services complete our offering: SICK LifeTime Services provide support throughout the machine life cycle and ensure safety and productivity.

For us, that is “Sensor Intelligence.”

## WORLDWIDE PRESENCE:

Contacts and other locations –[www.sick.com](http://www.sick.com)