



PLB-53A0101

PLB

ROBOT GUIDANCE SYSTEMS

SICK
Sensor Intelligence.



Ordering information

Type	part no.
PLB-53A0101	1140665

Other models and accessories → www.sick.com/PLB



Detailed technical data

Features

Product version	PLB-521
Field of view	Medium
Classification	Prime
Tasks	Position determination
Applications	Robot guidance
Camera type	3D snapshot
Example volume of view (L x W x H)	950 mm x 1000 mm x 600 mm
Image resolution	0.5 mm ... 0.8 mm, depending on the distance to the camera
Light source	LED, blue, 465 nm
LED class	Risk group 1
3D CAD format	IGES, STEP
Localization principle	Geometrical shape and edge localization
Technology	3D snapshot, image analysis

Mechanics/electronics

Connection type	PoE++
Supply voltage	24 V DC or PoE PD class 8 (90W)
Current consumption	10 A
Dimensions (L x W x H)	506 mm x 58 mm x 100 mm
Weight	1,660 g
Enclosure rating	IP65/ IP67

Performance

Part localization time	0.1 s ... 10 s, typical
Part size	(approx.) > 20 mm x 20 mm x 20 mm
Part characteristics	Simple and complex part shapes
2D colour sensor resolution	2 MP (1920 px x 1200 px)
3D sensor resolution	5 MP (2472 px x 2064 px)

Interfaces

Ethernet	✓ (2) , camera <--> PC, PC<--> robot
-----------------	--------------------------------------

Data transmission rate	1 Gbit/s (camera), 10/100 Mbit/s (robot)
Protocol	TCP/IP (camera)
Electrical connection	M12 female connector, 8-pin, X-coded

Ambient data

Ambient temperature, operation	0 °C ... +40 °C, Non-condensing
Shock load	60 g / 1,9 ms, 25 g / 6 ms ¹⁾
Vibration load	30-500 Hz / 5 g

¹⁾ IEC 60068-2-27.

General notes

Items supplied	C57 camera PLB Application Software
Factory calibrated	✓

Certificates

EU declaration of conformity	✓
UK declaration of conformity	✓
ACMA declaration of conformity	✓
China RoHS	✓
Information according to Art. 3 of Data Act (Regulation EU 2023/2854)	✓

Classifications

ECLASS 5.0	27381501
ECLASS 5.1.4	27381501
ECLASS 6.0	27381590
ECLASS 6.2	27381590
ECLASS 7.0	27381590
ECLASS 8.0	27381590
ECLASS 8.1	27381590
ECLASS 9.0	27381590
ECLASS 10.0	27381590
ECLASS 11.0	27381591
ECLASS 12.0	27381591

Dimensional drawing

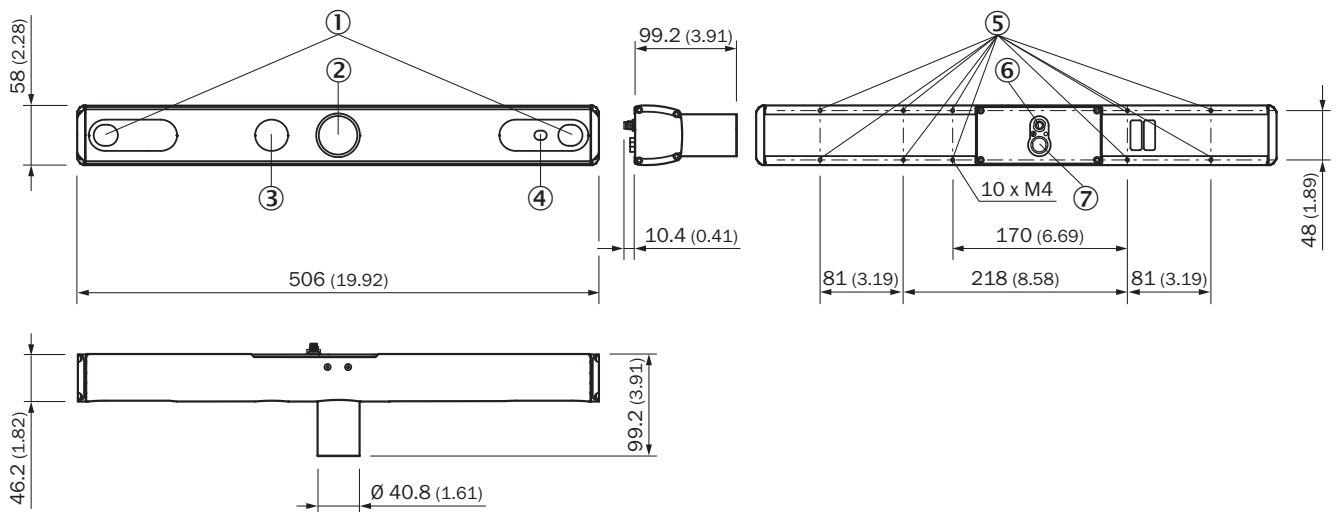

Dimensions in mm (inch)

- ① 3D sensors
- ② Projector
- ③ LED projection module
- ④ 2D sensor
- ⑤ Fastening threads (10x M4x0,7)
- ⑥ Power (M8, 4-pin)
- ⑦ Ethernet (M12, 8 pin, x-coded)

Detection volume and field of view

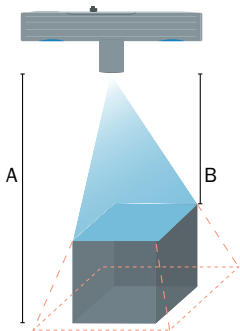

Parameter	PLB-521 small	PLB-521 medium	PLB-521 large
Image resolution	0.3 mm ... 0.5 mm, depending on the distance to the camera	0.5 mm ... 0.8 mm, depending on the distance to the camera	0.5 mm ... 2.1 mm, depending on the distance to the camera
Part size	(approx.) > 10 mm x 10 mm x 10 mm	(approx.) > 20 mm x 20 mm x 20 mm	(approx.) > 30 mm x 30 mm x 30 mm
Min. distance	1600 mm	1500 mm	1200 mm
Max. distance	2150 mm	2500 mm	5000 mm
Field of view at min. distance (L x W)	810 mm x 700 mm	1160 mm x 980 mm	1180 mm x 1040 mm
Field of view at max. distance (L x W)	1010 mm x 940 mm	1690 mm x 1640 mm	4020 mm x 4330 mm
Example volume of view (L x W x H)	650 mm x 700 mm x 400 mm	950 mm x 1000 mm x 600 mm	900 mm x 800 mm x 800 mm

Recommended accessories

Other models and accessories → www.sick.com/PLB

	Brief description	Type	part no.
Power supply units and power supply cables			
	<ul style="list-style-type: none"> • Input voltage: ≤ 230 V AC • Output voltage: 24 V DC • Output current: 10 A • Description: Power supply unit 	Power supply unit	6032863

SICK AT A GLANCE

SICK is one of the leading manufacturers of intelligent sensors and sensor solutions for industrial applications. A unique range of products and services creates the perfect basis for controlling processes securely and efficiently, protecting individuals from accidents and preventing damage to the environment.

We have extensive experience in a wide range of industries and understand their processes and requirements. With intelligent sensors, we can deliver exactly what our customers need. In application centers in Europe, Asia and North America, system solutions are tested and optimized in accordance with customer specifications. All this makes us a reliable supplier and development partner.

Comprehensive services complete our offering: SICK LifeTime Services provide support throughout the machine life cycle and ensure safety and productivity.

For us, that is “Sensor Intelligence.”

WORLDWIDE PRESENCE:

Contacts and other locations –www.sick.com