



DATA SHEET

PLB-51A0700

PLB
Robot guidance systems

SICK

Sensor Intelligence

ROBOT GUIDANCE SYSTEMS

PLB-51A0700

ORDERING INFORMATION

Type	part no.
PLB-51A0700	1140662

Further device versions and accessories at www.sick.com/PLB



DETAILED TECHNICAL DATA

FEATURES

Product version	PLB-521
Field of view	Large
Classification	Secondary camera
Tasks	Position determination
Applications	Robot guidance
Camera type	3D snapshot
Example volume of view (L x W x H)	900 mm x 800 mm x 800 mm
Image resolution	0.5 mm ... 2.1 mm, depending on the distance to the camera
Light source	LED, blue, 465 nm
LED class	Risk group 1
3D CAD format	IGES, STEP
Technology	3D snapshot, image analysis

MECHANICS/ELECTRONICS

Connection type	PoE++
Supply voltage	24 V DC or PoE PD class 8 (90W)
Current consumption	10 A
Dimensions (L x W x H)	506 mm x 58 mm x 100 mm
Weight	1,660 g
Enclosure rating	IP65/ IP67

PERFORMANCE

Part localization time	0.1 s ... 10 s, typical
Part size	(approx.) > 30 mm x 30 mm x 30 mm
Part characteristics	Simple and complex part shapes
2D colour sensor resolution	2 MP (1920 px x 1200 px)
3D sensor resolution	5 MP (2472 px x 2064 px)

INTERFACES

Ethernet	✓ (2) , camera <--> PC, PC<--> robot
Data transmission rate	1 Gbit/s (camera), 10/100 Mbit/s (robot)
Protocol	TCP/IP (camera)
Electrical connection	M12 female connector, 8-pin, X-coded

AMBIENT DATA

Ambient temperature, operation	0 °C ... +40 °C, Non-condensing
Shock load	60 g / 1,9 ms, 25 g / 6 ms ¹⁾
Vibration load	30-500 Hz / 5 g

¹⁾ IEC 60068-2-27.

GENERAL NOTES

Items supplied	C57 camera PLB Application Software
Factory calibrated	✓

CERTIFICATES

EU declaration of conformity	✓
UK declaration of conformity	✓
ACMA declaration of conformity	✓
China RoHS	✓
Information according to Art. 3 of Data Act (Regulation EU 2023/2854)	✓

DIMENSIONAL DRAWING

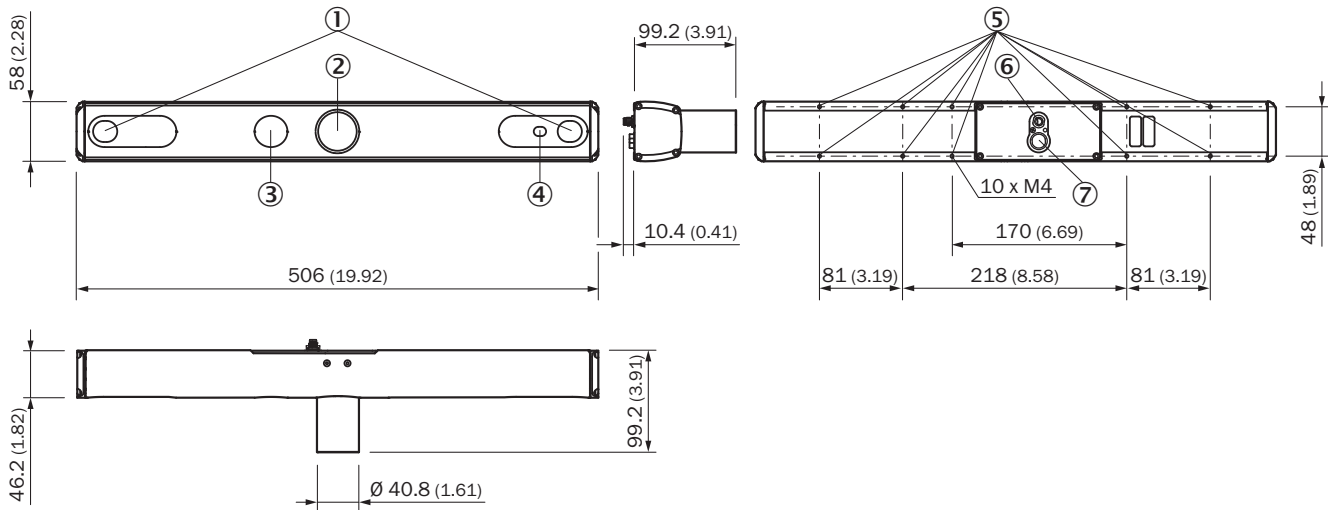

Dimensions in mm (inch)

- ① 3D sensors
- ② Projector
- ③ LED projection module
- ④ 2D sensor
- ⑤ Fastening threads (10x M4x0,7)
- ⑥ Power (M8, 4-pin)
- ⑦ Ethernet (M12, 8 pin, x-coded)

DETECTION VOLUME AND FIELD OF VIEW

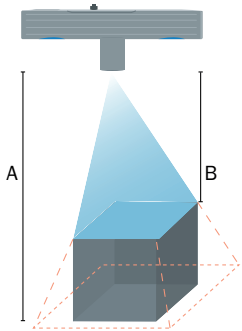

Parameter	PLB-521 small	PLB-521 medium	PLB-521 large
Image resolution	0.3 mm ... 0.5 mm, depending on the distance to the camera	0.5 mm ... 0.8 mm, depending on the distance to the camera	0.5 mm ... 2.1 mm, depending on the distance to the camera
Part size	(approx.) > 10 mm x 10 mm x 10 mm	(approx.) > 20 mm x 20 mm x 20 mm	(approx.) > 30 mm x 30 mm x 30 mm
Min. distance	1600 mm	1500 mm	1200 mm
Max. distance	2150 mm	2500 mm	5000 mm
Field of view at min. distance (L x W)	810 mm x 700 mm	1160 mm x 980 mm	1180 mm x 1040 mm
Field of view at max. distance (L x W)	1010 mm x 940 mm	1690 mm x 1640 mm	4020 mm x 4330 mm
Example volume of view (L x W x H)	650 mm x 700 mm x 400 mm	950 mm x 1000 mm x 600 mm	900 mm x 800 mm x 800 mm

Further information as well as suitable accessories, example applications and downloads such as CAD dimensional models, operating instructions and software can be found at www.sick.com/1140662



SICK AG
WALDKIRCH
GERMANY
SICK.COM

SICK AT A GLANCE

SICK is a leading global technology company for intelligent sensors and integrated solutions in industrial automation. Our technologies set benchmarks, making your industrial processes more efficient, safer and more sustainable – both in logistics and manufacturing operations.

SICK combines sensor intelligence with industry expertise and certified consulting services. We provide the ideal foundation for scalable as well as tailor-made automation solutions and create added value along the entire value chain. Our close partnerships with our customers are more than just a promise: Together, we optimize productivity, improve quality, protect health and safety, and help build a sustainable future. All with empathy and trust.

Since 1946, we have been developing innovative technologies with passion and a pioneering spirit. With a global network in around 40 countries, SICK has a global presence and is always close by. The company's headquarters are located in Waldkirch near Freiburg, Germany. Our customers benefit from our understanding of both local and global requirements, which enables us to deliver tailor-made solutions

SICK
Sensor Intelligence