



PALOC-VS

PALLOC

ROBOT GUIDANCE SYSTEMS

SICK
Sensor Intelligence.



Ordering information

Type	part no.
PALLOC-VS	1139985

Illustration may differ

Other models and accessories → www.sick.com/PALLOC



Detailed technical data

Features

Product version	Visionary-S AP
Example field of view	1.6 m x 1.3 m
Working distance	1.2 m ... 3.5 m
Laser class	1 (IEC 60825-1:2014) ¹⁾ EN 60825-1:2014+A11:2021
Localization principle	Deep Learning neural networks
System features	Deep learning-based standalone sensor for localizing parts using 3D color imaging
Technology	3D snapshot stereoscopy
Detection angle	60° x 50°
Angular resolution	0.094° x 0.098°
Lighting	Integrated
Illumination color	Infrared, laser, invisible, 808 nm
Description	PALLOC SensorApp with pretrained neural network and software license, preinstalled on the device

¹⁾ Complies with 21 CFR 1040.10 and 1040.11 except for deviations pursuant to IEC 60825-1 Ed. 3. according to Laser Notice No. 56 dated May 08, 2019.

Mechanics/electronics

Supply voltage	24 V DC ± 15 %
Power consumption	19 W, Typical (without digital I/Os)
Housing color	Blue, black
Dimensions (L x W x H)	162 mm x 93 mm x 78 mm (without cooling fins)
Weight	1.7 kg, without cooling fins
Enclosure rating	IP67
Protection class	III
Connection types	Power/I/O: M12 17-pin, A-coded Gigabit Ethernet: M12, 8-pin, X-coded
Peak current	3 A

Performance

Part localization time	1 s (Fast mode, robot mounted at distance of 1.2 m) 3 s (Long distance mode, stationary mounting at distance of 1.5...3.5 m)
-------------------------------	---------------------------------------------------------------------------------------------------------------------------------

¹⁾ Part of the processor resources are required for internal processing. The current processor load is displayed in the CPU monitor in SICK AppStudio.

Localization accuracy	< +/- 5 mm and < +/- 1° (typical)
Part size	> 100 x 100 mm at a distance of 1.2 m > 250 x 250 mm at a distance of 3.5 m
Pixel count	640 px x 512 px
Switch-on delay	< 25 s (typical)
Processor	1.2 GHz, 4 × ARM Cortex A72 ¹⁾

¹⁾ Part of the processor resources are required for internal processing. The current processor load is displayed in the CPU monitor in SICK AppStudio.

Interfaces

Ethernet	✓
Data transmission rate	Communication interface Gigabit Ethernet (TCP/IP)
Protocol	TCP/IP JSON, XML and CSV (robot), TCP/IP (operator) FTP
User interface	Web server
Optical indicators	2 status LEDs
Data storage and retrieval	Image and data logging via microSD memory card and external FTP

Ambient data

Ambient temperature, operation	0 °C ... +40 °C, without cooling fins
Ambient temperature, storage	-20 °C ... +70 °C
Shock load	EN 60068-2-27
Vibration resistance	EN 60068-2-6, EN 60068-2-64
Ambient light immunity	< 40 klx, Sunlight
Electromagnetic compatibility (EMC)	EN 61000-6-2:2005-08, EN 61000-6-3:2007-01

General notes

Factory calibrated	✓
Mounting	Robot or stationary mounted sensor

Certificates

EU declaration of conformity	✓
UK declaration of conformity	✓
ACMA declaration of conformity	✓
China RoHS	✓
Information according to Art. 3 of Data Act (Regulation EU 2023/2854)	✓

Classifications

ECLASS 5.0	27381501
ECLASS 5.1.4	27381501
ECLASS 6.0	27381590
ECLASS 6.2	27381590
ECLASS 7.0	27381590
ECLASS 8.0	27381590
ECLASS 8.1	27381590
ECLASS 9.0	27381590

ECLASS 10.0	27381590
ECLASS 11.0	27381591
ECLASS 12.0	27381591

Dimensional drawing

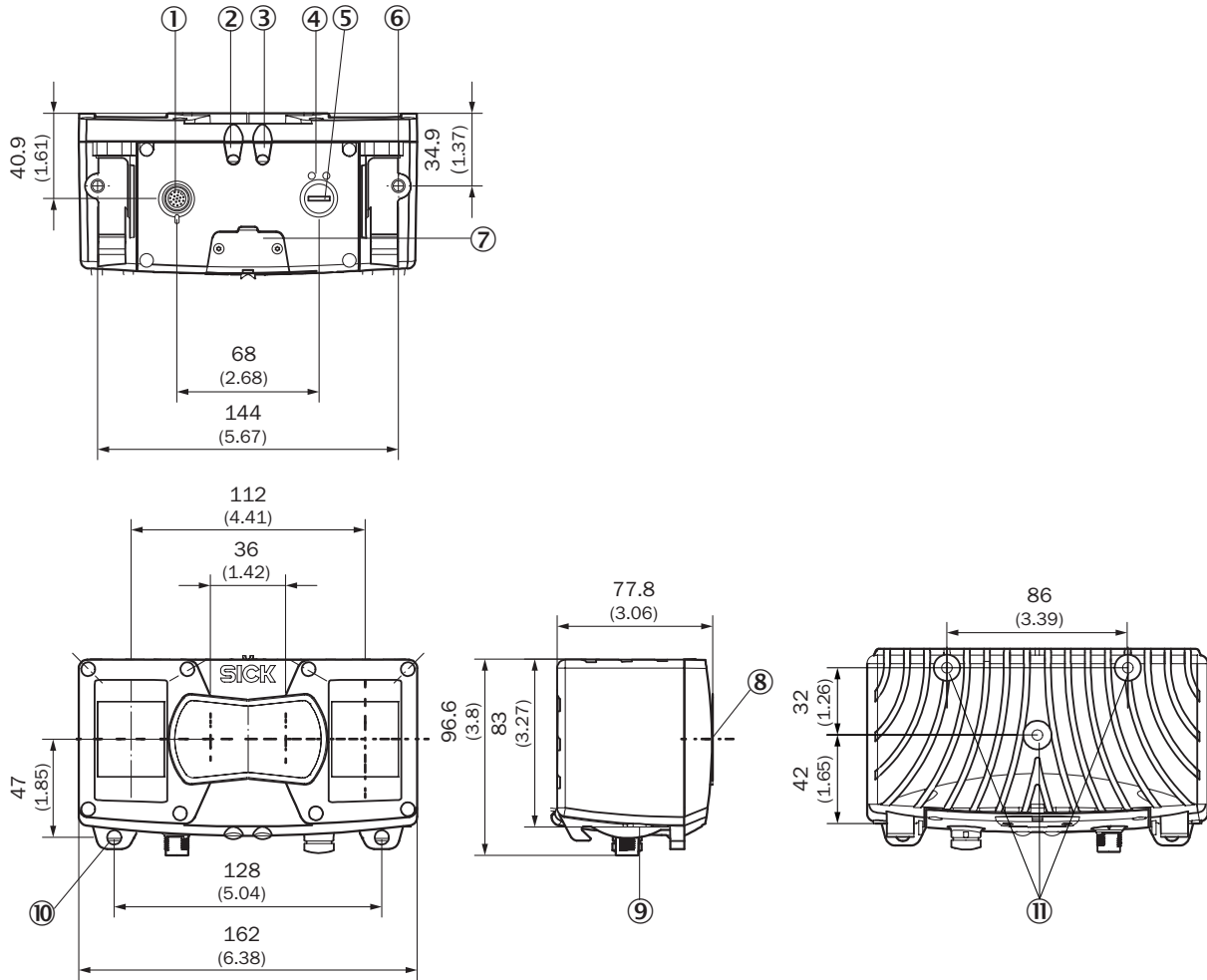

Dimensions in mm (inch)

- ① Power/I/O: M12 17-pin, A-coded
- ② device display
- ③ application display
- ④ ethernet status displays
- ⑤ Gigabit Ethernet: M12, 8-pin, X-coded
- ⑥ M6 threaded hole, 7 mm deep (2x), for mounting
- ⑦ service interface
- ⑧ Optical axis
- ⑨ bracket interface
- ⑩ bracket attachment
- ⑪ M6 threaded hole, 10 mm deep (3x), for mounting

Gigabit Ethernet

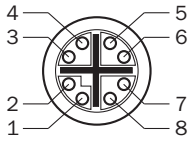

Gigabit Ethernet: M12, 8-pin, X-coded

- ① TRD0_P
- ② TRD0_N
- ③ TRD1_P
- ④ TRD1_N
- ⑤ TRD3_P
- ⑥ TRD3_N
- ⑦ TRD2_P
- ⑧ TRD2_N

Connection: Power/I/O

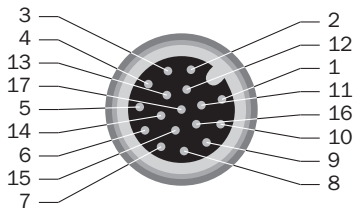

Power/I/O: M12 17-pin, A-coded

- ① GND – reference mass
- ② Supply voltage
- ③ CAN L – reserved, not implemented. Do not connect to VCC!
- ④ CAN H – reserved, not implemented. Do not connect to VCC!
- ⑤ TD+ (RS-422/485) Host – reserved, not implemented. Do not connect to VCC!
- ⑥ TD- (RS-422/485) Host, TxD (RS-232), Host – reserved, not implemented. Do not connect to VCC!
- ⑦ TxD (RS-232), Aux – service only
- ⑧ RxD (RS-232), Aux – service only
- ⑨ SENS GND – GND for electrically decoupled inputs
- ⑩ SENS IN1 – switch input, electrically decoupled
- ⑪ RD+ (RS-422) Host – reserved, not implemented. Do not connect to VCC!
- ⑫ RD- (RS-422/485) Host, RxD (RS-232), Host – reserved, not implemented. Do not connect to VCC!
- ⑬ INOUT 1 - Programmable digital I/O
- ⑭ INOUT 2 - Programmable digital I/O
- ⑮ SENS IN2 – switch input, electrically decoupled
- ⑯ INOUT 3 - Programmable digital I/O
- ⑰ INOUT 4 - Programmable digital I/O

SICK AT A GLANCE

SICK is one of the leading manufacturers of intelligent sensors and sensor solutions for industrial applications. A unique range of products and services creates the perfect basis for controlling processes securely and efficiently, protecting individuals from accidents and preventing damage to the environment.

We have extensive experience in a wide range of industries and understand their processes and requirements. With intelligent sensors, we can deliver exactly what our customers need. In application centers in Europe, Asia and North America, system solutions are tested and optimized in accordance with customer specifications. All this makes us a reliable supplier and development partner.

Comprehensive services complete our offering: SICK LifeTime Services provide support throughout the machine life cycle and ensure safety and productivity.

For us, that is “Sensor Intelligence.”

WORLDWIDE PRESENCE:

Contacts and other locations –www.sick.com