

PHOTOELECTRIC SENSORS

WLA4SP-31312130ZZZ

ORDERING INFORMATION

Type	part no.
WLA4SP-31312130ZZZ	1139130

Further device versions and accessories at www.sick.com/W4



Illustration may differ



DETAILED TECHNICAL DATA

FEATURES

Functional principle	Photoelectric retro-reflective sensor	
Functional principle detail	Without reflector minimum distance (autocollimation/coaxial optics)	
Sensing range	Sensing range min.	0 m
	Sensing range max.	7.1 m
Maximum distance range from reflector to sensor (operating reserve 1)	0 m ... 7.1 m	
Recommended distance range from reflector to sensor (operating reserve 3,75)	0 m ... 5 m	
Reference reflector	Reflector PL80	
Recommended sensing range for the best performance	0 m ... 5 m	
Polarisation filter	Yes	
Emitted beam	Light source	PinPoint LED
	Type of light	Visible red light
	Shape of light spot	Point-shaped
	Light spot size (distance)	150 mm (5 m)
Maximum dispersion of the emitted beam around the standardized transmission axis (squint angle)	< +/- 1.5° (at T ₀ = +23 °C)	
Key LED figures	Normative reference	EN 62471:2008-09 IEC 62471:2006, modified
	LED risk group marking	Free group
	Wave length	635 nm
	Average service life	100,000 h at T _a = +25 °C
Adjustment	Teach-in button	BluePilot

		For sensitivity adjustment
Display	LED blue	BluePilot: Alignment aid
	LED green	Operating indicator Static on: power on
	LED yellow	Status of received light beam Static on: object not present Static off: object present
		Flashing: Below the 1.5 function reserve
Special applications		Detecting objects wrapped in film

SAFETY-RELATED PARAMETERS

MTTF _D	1,601 years
DC _{avg}	0%

ELECTRONICS

Supply voltage U _B		10 V DC ... 30 V DC ¹⁾
Ripple		≤ 5 V _{pp}
Usage category		DC-12 (According to EN 60947-5-2) DC-13 (According to EN 60947-5-2)
Current consumption		≤ 20 mA, without load. At U _B = 24 V
Protection class		III
Digital output	Number	1
	Type	Push-pull: PNP/NPN
	Switching mode	Light switching
	Signal voltage PNP HIGH/LOW	Approx. U _B -2.5 V / 0 V
	Signal voltage NPN HIGH/LOW	Approx. U _B / < 2.5 V
	Output current I _{max.}	≤ 100 mA
	Circuit protection outputs	Reverse polarity protected Overcurrent protected Short-circuit protected
	Response time	≤ 500 μs
	Repeatability (response time)	150 μs
	Switching frequency	1,000 Hz
Pin/Wire assignment	Function of pin 4/black (BK)	Digital output, light switching, object present → output Q _L LOW ²⁾

¹⁾ Limit values.

²⁾ This switching output must not be connected to another output.

MECHANICS

Housing		Rectangular
Design detail		Slim
Dimensions (W x H x D)		12.1 mm x 41.9 mm x 18.6 mm
Connection		Cable with connector M8, 3-pin, 110 mm
Connection detail	Deep-freeze property	Do not bend below 0 °C
	Conductor size	0.14 mm ²
	Cable diameter	Ø 3.4 mm
	Length of cable (L)	77 mm
Material	Housing	Plastic, VISTAL®
	Front screen	Plastic, PMMA
	Cable	Plastic, PVC
	Male connector	Plastic, VISTAL®

Maximum tightening torque of the fixing screws	0.4 Nm
--	--------

AMBIENT DATA

Enclosure rating	IP66 (EN 60529) IP67 (EN 60529)
Ambient operating temperature	-40 °C ... +60 °C
Ambient temperature, storage	-40 °C ... +75 °C
Typ. Ambient light immunity	Artificial light: ≤ 50,000 lx Sunlight: ≤ 50,000 lx
Shock resistance	30 g, 11 ms (3 positive and 3 negative shocks along X, Y, Z axes, 18 total shocks (EN60068-2-27))
Vibration resistance	10 Hz ... 1,000 Hz (Amplitude 1 mm, 3 x 30 min (EN60068-2-6))
Air humidity	35 % ... 95 %, relative humidity (no condensation)
Electromagnetic compatibility (EMC)	EN 60947-5-2
Resistance to cleaning agent	ECOLAB
UL File No.	NRKH.E181493 & NRKH7.E181493

CERTIFICATES

EU declaration of conformity	✓
UK declaration of conformity	✓
ACMA declaration of conformity	✓
Moroccan declaration of conformity	✓
China RoHS	✓
cULus certificate	✓

DIMENSIONAL DRAWING, CONNECTION

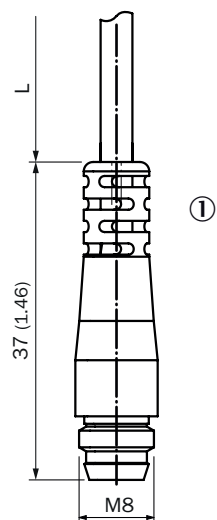

Dimensions in mm (inch)
 For length of cable (L), see technical data
 ① cable with connector M8

DISPLAY AND ADJUSTMENT ELEMENTS

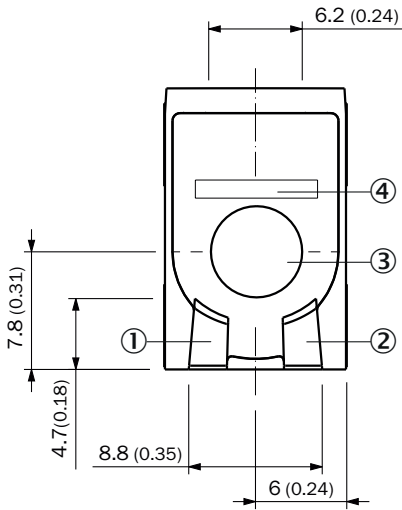

- ① LED green
- ② LED yellow
- ③ Teach-in button
- ④ LED blue

CONNECTION TYPE CONNECTOR M8, 3-PIN

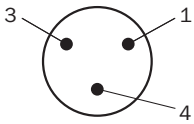

CONNECTION DIAGRAM CD-045

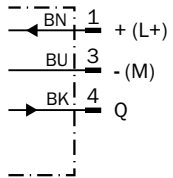

TRUTH TABLE PUSH-PULL: PNP/NPN - LIGHT SWITCHING Q

	Light switching Q (normally closed (upper switch), normally open (lower switch))	
	Object not present → Output HIGH	Object present → Output LOW
Light receive	✓	✗
Light receive indicator	☀	✗
Load resistance to L+	✗	⚡
Load resistance to M	⚡	✗

CHARACTERISTIC CURVE CHEMICAL-RESISTANT REFLECTORS

Operating reserve

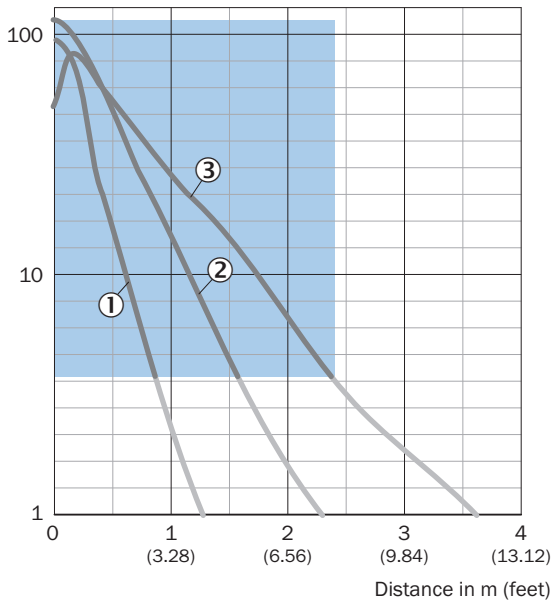

Recommended sensing range for the best performance

- ① PL10F CHEM reflector
- ② Reflector PL20 CHEM
- ③ Reflector P250 CHEM

CHARACTERISTIC CURVE FINE TRIPLE REFLECTORS

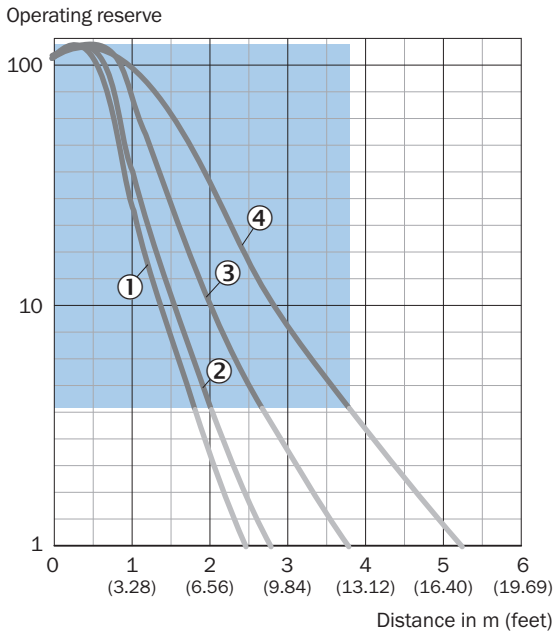

Recommended sensing range for the best performance

- ① PL10F reflector
- ② PL10FH-1 reflector
- ③ Reflector PL20F
- ④ Reflector P250F

CHARACTERISTIC CURVE REFLECTIVE TAPE

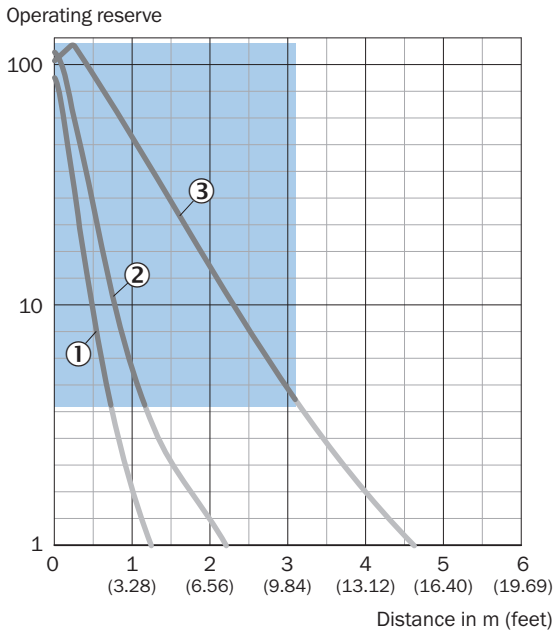

Recommended sensing range for the best performance

- ① Reflective tape REF-DG
- ② Reflective tape REF-IRF-56
- ③ Reflective tape REF-AC1000

CHARACTERISTIC CURVE STANDARD REFLECTORS

Operating reserve

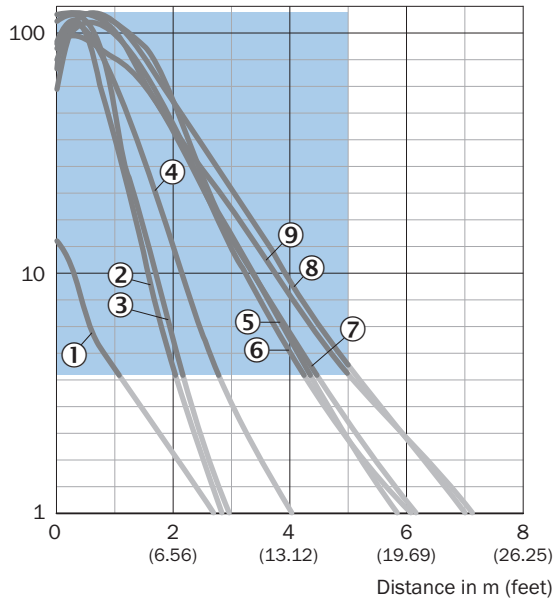

Recommended sensing range for the best performance

- ① Reflector PL40A Antifog
- ② Reflector PL20A
- ③ reflector PL22-2
- ④ Reflector P250H
- ⑤ Reflector P250
- ⑥ Reflector PL30A
- ⑦ Reflector PL40A
- ⑧ Reflector C110A
- ⑨ Reflector PL80A

LIGHT SPOT SIZE

Dimensions in mm (inch)

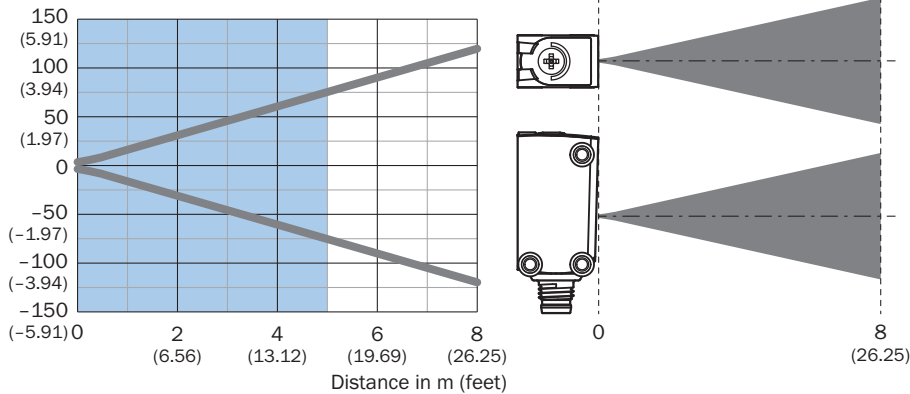

SENSING RANGE DIAGRAM CHEMICAL-RESISTANT REFLECTORS

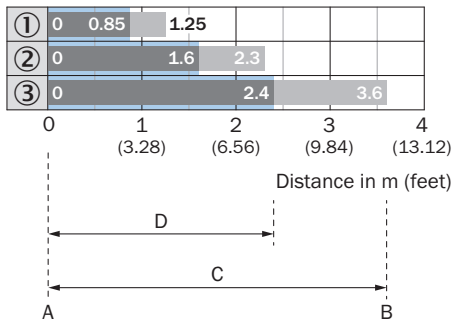

Recommended sensing range for the best performance

1	PL10F CHEM reflector
2	Reflector PL20 CHEM
3	Reflector P250 CHEM
A	Sensing range min. in m
B	Sensing range max. in m
C	Maximum distance range from reflector to sensor (operating reserve 1)
D	Recommended distance range from reflector to sensor (operating reserve 3,75)

SENSING RANGE DIAGRAM FINE TRIPLE REFLECTORS

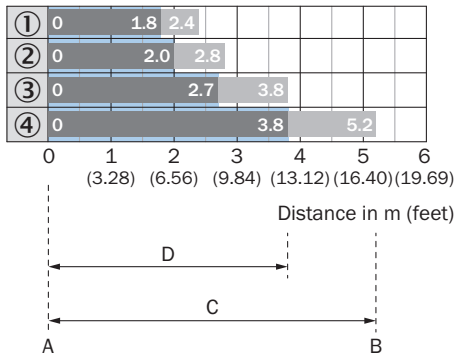

Recommended sensing range for the best performance

1	PL10F reflector
2	PL10FH-1 reflector
3	Reflector PL20F
4	Reflector P250F
A	Sensing range min. in m
B	Sensing range max. in m
C	Maximum distance range from reflector to sensor (operating reserve 1)
D	Recommended distance range from reflector to sensor (operating reserve 3,75)

SENSING RANGE DIAGRAM REFLECTIVE TAPE

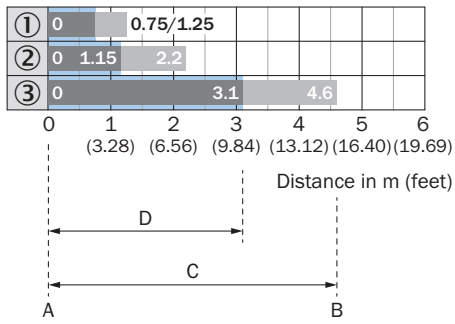

Recommended sensing range for the best performance

1	Reflective tape REF-DG
2	Reflective tape REF-IRF-56
3	Reflective tape REF-AC1000
A	Sensing range min. in m
B	Sensing range max. in m
C	Maximum distance range from reflector to sensor (operating reserve 1)
D	Recommended distance range from reflector to sensor (operating reserve 3,75)

SENSING RANGE DIAGRAM STANDARD REFLECTORS

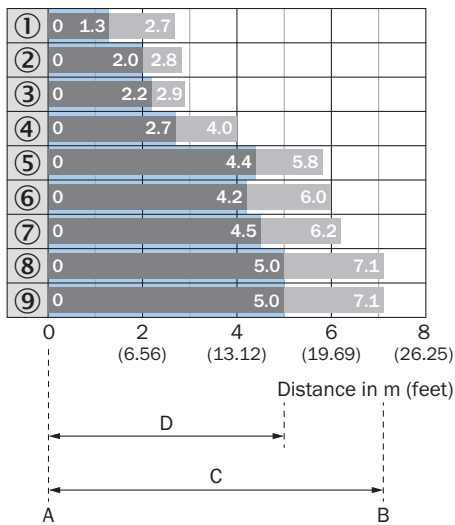

Recommended sensing range for the best performance

1	Reflector PL40A Antifog
2	Reflector PL20A
3	Reflector PL22-2
4	Reflector P250H
5	Reflector P250
6	Reflector PL30A
7	Reflector PL40A
8	Reflector C110A

9	Reflector PL80A
A	Sensing range min. in m
B	Sensing range max. in m
C	Maximum distance range from reflector to sensor (operating reserve 1)
D	Recommended distance range from reflector to sensor (operating reserve 3,75)

DIMENSIONAL DRAWING, SENSOR

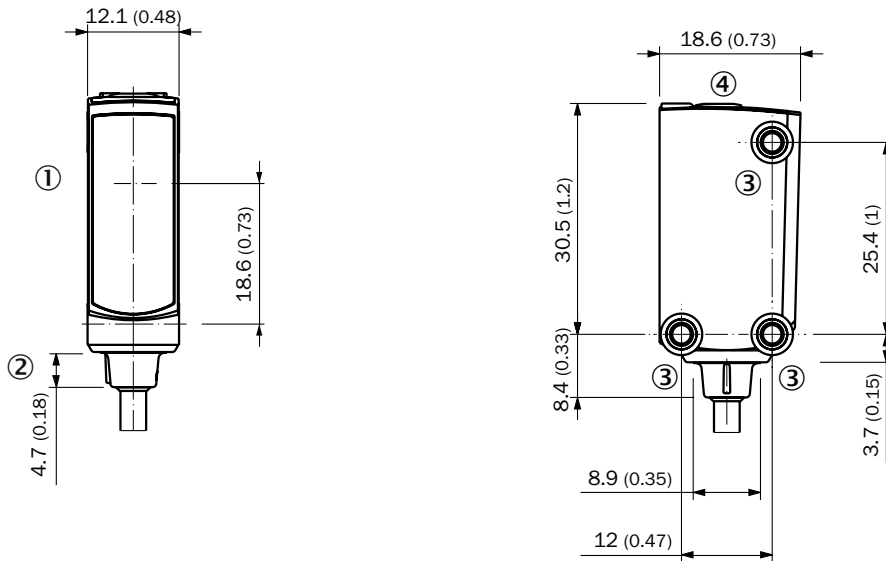

Dimensions in mm (inch)

- ① Center of optical axis
- ② Connection
- ③ M3 mounting hole
- ④ display and adjustment elements

Further information as well as suitable accessories, example applications and downloads such as CAD dimensional models, operating instructions and software can be found at www.sick.com/1139130



SICK AG
WALDKIRCH
GERMANY
SICK.COM

SICK AT A GLANCE

SICK is a leading global technology company for intelligent sensors and integrated solutions in industrial automation. Our technologies set benchmarks, making your industrial processes more efficient, safer and more sustainable – both in logistics and manufacturing operations.

SICK combines sensor intelligence with industry expertise and certified consulting services. We provide the ideal foundation for scalable as well as tailor-made automation solutions and create added value along the entire value chain. Our close partnerships with our customers are more than just a promise: Together, we optimize productivity, improve quality, protect health and safety, and help build a sustainable future. All with empathy and trust.

Since 1946, we have been developing innovative technologies with passion and a pioneering spirit. With a global network in around 40 countries, SICK has a global presence and is always close by. The company's headquarters are located in Waldkirch near Freiburg, Germany. Our customers benefit from our understanding of both local and global requirements, which enables us to deliver tailor-made solutions

SICK
Sensor Intelligence