



# WTM4SP-84161120A00

W4

PHOTOELECTRIC SENSORS

**SICK**  
Sensor Intelligence.



Illustration may differ



### Ordering information

Type	part no.
WTM4SP-84161120A00	1136368

Other models and accessories → [www.sick.com/W4](http://www.sick.com/W4)

### Detailed technical data

#### Features

<b>Functional principle</b>	Photoelectric proximity sensor
<b>Functional principle detail</b>	Background suppression, Foreground suppression, MultiMode, distance value
<b>MultiMode</b>	<ul style="list-style-type: none"> <li>1 Background suppression</li> <li>2 Foreground suppression</li> <li>3 Two Value Teach-in</li> <li>4 Two independent switching points</li> <li>5 Window Mode</li> <li>6 ApplicationSelect</li> <li>M manual / measurement</li> </ul>
<b>Sensing range</b>	
Sensing range min.	4 mm (mode 1, 3, 4, 5)
	0 mm (mode 2)
	4 mm (mode 1 and 6 combined)
Sensing range max.	250 mm (mode 1, 3, 4, 5)
	250 mm (mode 2)
	500 mm (mode 1 and 6 combined)
Adjustable switching threshold for background suppression	10 mm ... 250 mm (mode 1, 3, 4, 5)
	10 mm ... 500 mm (mode 1 and 6 combined)
Adjustable switching threshold for foreground suppression	10 mm ... 250 mm (mode 2)
Reference object	Object with 90% remission factor (complies with standard white according to DIN 5033)
Minimum distance between set sensing range and background (black 6% / white 90%)	5 mm, at a distance of 150 mm (mode 1, 3, 4, 5)
	1.8 mm, at a distance of 100 mm (mode 2)

<sup>1)</sup> 90% remission factor.

<sup>2)</sup> Equivalent to 1  $\sigma$ .

<sup>3)</sup> See repeatability characteristic lines.

Minimum object height at set sensing range in front of black background (6% remission factor)		8 mm, at a distance of 250 mm (mode 1 and 6 combined)
		1.8 mm, at a distance of 100 mm (mode 2)
	Recommended sensing range for the best performance	40 mm ... 170 mm (mode 1, 3, 4, 5)
		40 mm ... 140 mm (mode 2)
<b>Distance value</b>		50 mm ... 200 mm (mode 1 and 6 combined)
	Measuring range	10 mm ... 250 mm
	Resolution	0.1 mm
	Repeatability	0,2 mm ... 6 mm <sup>1) 2) 3)</sup>
	Accuracy	Typ. 5.0 mm at 10 ... 50 mm distance <sup>1)</sup>
		Typ. 6.0 mm at 15 ... 100 mm distance <sup>1)</sup>
		Typ. 8.0 mm at 100 ... 150 mm distance <sup>1)</sup>
		Typ. 12 mm at 150 ... 200 mm distance <sup>1)</sup>
		Typ. 16 mm at 200 ... 250 mm distance <sup>1)</sup>
	Distance value output	Via IO-Link
Update rate of the distance value	20 ms	
<b>Emitted beam</b>	Light source	PinPoint LED
	Type of light	Visible red light
	Shape of light spot	Point-shaped
	Light spot size (distance)	4 mm (150 mm)
	Maximum dispersion of the emitted beam around the standardized transmission axis (squint angle)	< +/- 1.5° (at T <sub>U</sub> = +23 °C)
	<b>Key LED figures</b>	Normative reference
LED risk group marking		Free group
Wave length		635 nm
Average service life		100,000 h at T <sub>a</sub> = +25 °C
<b>Smallest detectable object (MDO) typ.</b>		0.2 mm, At 180 mm distance, mode 1, 3, 4, 5
		0.6 mm, at a distance of 140 mm, mode 2
		0.1 mm, At 180 mm distance, mode 1 and 6 combined
		Object with 90% remission factor (complies with standard white according to DIN 5033)
<b>Adjustment</b>	Teach-Turn adjustment	BluePilot For adjusting the sensing range with mode selection
	IO-Link	For configuring the sensor parameters and Smart Task functions
<b>Display</b>		

<sup>1)</sup> 90% remission factor.

<sup>2)</sup> Equivalent to 1 σ.

<sup>3)</sup> See repeatability characteristic lines.

	LED blue	BluePilot: Display of mode, display of output states Q <sub>L1</sub> (LED 3 permanently on) and Q <sub>L2</sub> (LED 5 permanently on)
	LED green	Operating indicator Static on: power on Flashing: IO-Link mode
	LED yellow	Status of received light beam Static on: object present Static off: object not present
<b>Special features</b>		MultiMode
<b>Special applications</b>		Detecting uneven, shiny objects, Detection of poorly remitting and tilted objects

<sup>1)</sup> 90% remission factor.

<sup>2)</sup> Equivalent to 1  $\sigma$ .

<sup>3)</sup> See repeatability characteristic lines.

### Safety-related parameters

<b>MTTF<sub>D</sub></b>	1,404 years
<b>DC<sub>avg</sub></b>	0%

### Communication interface

<b>IO-Link</b>	✓, IO-Link V1.1
Data transmission rate	COM2 (38,4 kBaud)
Cycle time	2.3 ms
Process data length	16 Bit
Process data structure	Bit 0 = switching signal Q <sub>L1</sub> Bit 1 = switching signal Q <sub>L2</sub> Process data structure: Bit 2 ... 15 = current receiver level (live) mode 1-5. Process data structure B: Bit 2 ... 15 = distance value 0.1 mm (live) mode M.
VendorID	26
DeviceID HEX	0x80031B
DeviceID DEC	8389403
Compatible master port type	A
SIO mode support	Yes

### Electronics

<b>Supply voltage U<sub>B</sub></b>	10 V DC ... 30 V DC <sup>1)</sup>
<b>Ripple</b>	≤ 5 V <sub>pp</sub>
<b>Usage category</b>	DC-12 (According to EN 60947-5-2) DC-13 (According to EN 60947-5-2)
<b>Current consumption</b>	≤ 20 mA, without load. At U <sub>B</sub> = 24 V
<b>Protection class</b>	III
<b>Digital output</b>	
Number	2

<sup>1)</sup> Limit values.

<sup>2)</sup> Signal transit time with resistive load in switching mode.

<sup>3)</sup> Mode 1, 2, 3.

<sup>4)</sup> Mode 4, 5.

<sup>5)</sup> Mode 1 and 6 combined.

<sup>6)</sup> With light/dark ratio 1:1.

<sup>7)</sup> This switching output must not be connected to another output.

Type	Push-pull: PNP/NPN
Switching mode	Light/dark switching
Signal voltage PNP HIGH/LOW	Approx. $U_B - 2.5 \text{ V} / 0 \text{ V}$
Signal voltage NPN HIGH/LOW	Approx. $U_B / < 2.5 \text{ V}$
Output current $I_{max}$	$\leq 100 \text{ mA}$
Circuit protection outputs	Reverse polarity protected
	Overcurrent protected
	Short-circuit protected
Response time	$\leq 500 \mu\text{s}$ <sup>2) 3)</sup>
	$\leq 1,000 \mu\text{s}$ <sup>2) 4)</sup>
	$\leq 15 \text{ ms}$ <sup>2) 5)</sup>
Repeatability (response time)	$500 \mu\text{s}$ (mode 1, 2, 3) <sup>2)</sup>
	$350 \mu\text{s}$ (mode 4, 5) <sup>2)</sup>
	$5 \text{ ms}$ (mode 1 and 6 combined) <sup>2)</sup>
Switching frequency	$1,000 \text{ Hz}$ (mode 1, 2, 3) <sup>6)</sup>
	$500 \text{ Hz}$ (mode 4, 5) <sup>6)</sup>
	$30 \text{ Hz}$ (mode 1 and 6 combined) <sup>6)</sup>
<b>Pin/Wire assignment</b>	
Function of pin 4/black (BK)	Digital output, light switching, object present → output QL1 HIGH (Mode 1, 3, 4, 5, 6) <sup>7)</sup>
	Digital output, dark switching, object present → output $\bar{Q}L1$ HIGH (Mode 2) <sup>7)</sup>
	IO-Link communication C
Function of pin 4/black (BK) – detail	The pin 4 function of the sensor can be configured Additional possible settings via IO-Link
Function of pin 2/white (WH)	Digital output, dark switching, object present → output $\bar{Q}L1$ LOW (Mode 1, 3, 5, 6) <sup>7)</sup>
	Digital output, light switching, object present → output QL1 LOW (Mode 2) <sup>7)</sup>
	Digital output, light switching, object present → output QL2 HIGH (Mode 4) <sup>7)</sup>
Function of pin 2/white (WH) – detail	The pin 2 function of the sensor can be configured Additional possible settings via IO-Link

<sup>1)</sup> Limit values.

<sup>2)</sup> Signal transit time with resistive load in switching mode.

<sup>3)</sup> Mode 1, 2, 3.

<sup>4)</sup> Mode 4, 5.

<sup>5)</sup> Mode 1 and 6 combined.

<sup>6)</sup> With light/dark ratio 1:1.

<sup>7)</sup> This switching output must not be connected to another output.

## Mechanics

<b>Housing</b>	Rectangular
<b>Design detail</b>	Slim
<b>Dimensions (W x H x D)</b>	12.1 mm x 41.9 mm x 18.6 mm
<b>Connection</b>	Cable with M12 male connector, 4-pin, 190 mm
<b>Connection detail</b>	

Deep-freeze property	Do not bend below 0 °C
Conductor size	0.14 mm <sup>2</sup>
Cable diameter	Ø 3.4 mm
Length of cable (L)	142 mm
Length of male connector	48 mm
<b>Material</b>	
Housing	Plastic, VISTAL®
Front screen	Plastic, PMMA
Cable	Plastic, PVC
Male connector	Plastic, VISTAL®
<b>Maximum tightening torque of the fixing screws</b>	0.4 Nm

### Ambient data

<b>Enclosure rating</b>	IP66 (EN 60529) IP67 (EN 60529)
<b>Ambient operating temperature</b>	-40 °C ... +60 °C
<b>Ambient temperature, storage</b>	-40 °C ... +75 °C
<b>Typ. Ambient light immunity</b>	Artificial light: ≤ 50,000 lx Sunlight: ≤ 50,000 lx
<b>Shock resistance</b>	30 g, 11 ms (3 positive and 3 negative shocks along X, Y, Z axes, 18 total shocks (EN60068-2-27))
<b>Vibration resistance</b>	10 Hz ... 1,000 Hz (Amplitude 1 mm, 3 x 30 min (EN60068-2-6))
<b>Air humidity</b>	35 % ... 95 %, relative humidity (no condensation)
<b>Electromagnetic compatibility (EMC)</b>	EN 60947-5-2
<b>Resistance to cleaning agent</b>	ECOLAB
<b>UL File No.</b>	NRKH.E181493 & NRKH7.E181493

### Smart Task

<b>Smart Task name</b>	Base logics
<b>Logic function</b>	Direct AND OR
<b>Timer function</b>	Deactivated Switch-on delay Off delay ON and OFF delay Impulse (one shot)
<b>Inverter</b>	Yes
<b>Switching frequency</b>	SIO Logic: 900 Hz (mode 1, 2, 3) <sup>1)</sup> SIO Logic: 450 Hz (mode 4, 5) <sup>1)</sup> SIO Logic: 30 Hz (mode 1 and 6 combined) <sup>1)</sup> IOL: 800 Hz (mode 1, 2, 3) <sup>2)</sup> IOL: 450 Hz (mode 4, 5) <sup>2)</sup> IOL: 30 Hz (mode 1 and 6 combined) <sup>2)</sup>
<b>Response time</b>	SIO Logic: 550 µs (mode 1, 2, 3) <sup>1)</sup> SIO Logic: 1100 µs (mode 4, 5) <sup>1)</sup>

<sup>1)</sup> Use of Smart Task functions without IO-Link communication (SIO mode).

<sup>2)</sup> Use of Smart Task functions with IO-Link communication function.

	SIO Logic: 15 ms (mode 1 and 6 combined) <sup>1)</sup> IOL: 600 µs (mode 1, 2, 3) <sup>2)</sup> IOL: 1100 µs (mode 4, 5) <sup>2)</sup> IOL: 15 ms (mode 1 and 6 combined) <sup>2)</sup>
<b>Repeatability</b>	SIO Logic: 200 µs <sup>1)</sup> SIO Logic: 400 µs <sup>1)</sup> SIO Logic: 5 ms <sup>1)</sup> IOL: 250 µs <sup>2)</sup> IOL: 450 µs <sup>2)</sup> IOL: 5 ms <sup>2)</sup>
<b>Switching signal</b>	
Switching signal Q <sub>L1</sub>	Switching output
Switching signal $\bar{Q}$ <sub>L1</sub>	Switching output

<sup>1)</sup> Use of Smart Task functions without IO-Link communication (SIO mode).

<sup>2)</sup> Use of Smart Task functions with IO-Link communication function.

### Diagnosis

<b>Device temperature</b>	
Measuring range	Very cold, cold, moderate, warm, hot
<b>Device status</b>	Yes
<b>Detailed device status</b>	Yes
<b>Operating hour counter</b>	Yes
<b>Operating hours counter with reset function</b>	Yes
<b>Quality of teach</b>	Yes

### Certificates

<b>EU declaration of conformity</b>	✓
<b>UK declaration of conformity</b>	✓
<b>ACMA declaration of conformity</b>	✓
<b>Moroccan declaration of conformity</b>	✓
<b>China RoHS</b>	✓
<b>cULus certificate</b>	✓
<b>Information according to Art. 3 of Data Act (Regulation EU 2023/2854)</b>	✓

### Classifications

<b>ECLASS 5.0</b>	27270904
<b>ECLASS 5.1.4</b>	27270904
<b>ECLASS 6.0</b>	27270904
<b>ECLASS 6.2</b>	27270904
<b>ECLASS 7.0</b>	27270904
<b>ECLASS 8.0</b>	27270904
<b>ECLASS 8.1</b>	27270904
<b>ECLASS 9.0</b>	27270904
<b>ECLASS 10.0</b>	27270904
<b>ECLASS 11.0</b>	27270904

<b>ECLASS 12.0</b>	27270903
<b>ETIM 5.0</b>	EC002719
<b>ETIM 6.0</b>	EC002719
<b>ETIM 7.0</b>	EC002719
<b>ETIM 8.0</b>	EC002719
<b>UNSPSC 16.0901</b>	39121528

### Dimensional drawing, connection

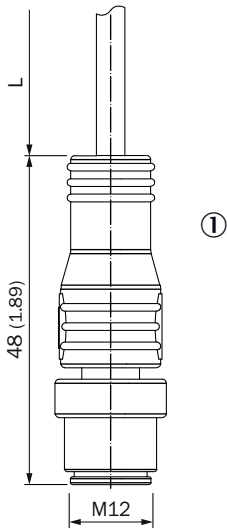

Dimensions in mm (inch)

For length of cable (L), see technical data

① Cable with M12 male connector

### display and adjustment elements

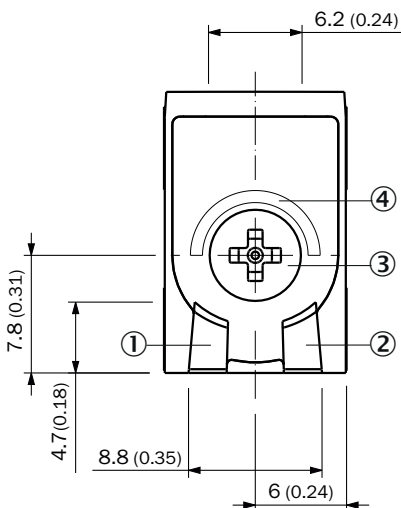

① LED green

② LED yellow

- ③ Teach-Turn adjustment
- ④ LED blue

Display and setting detail

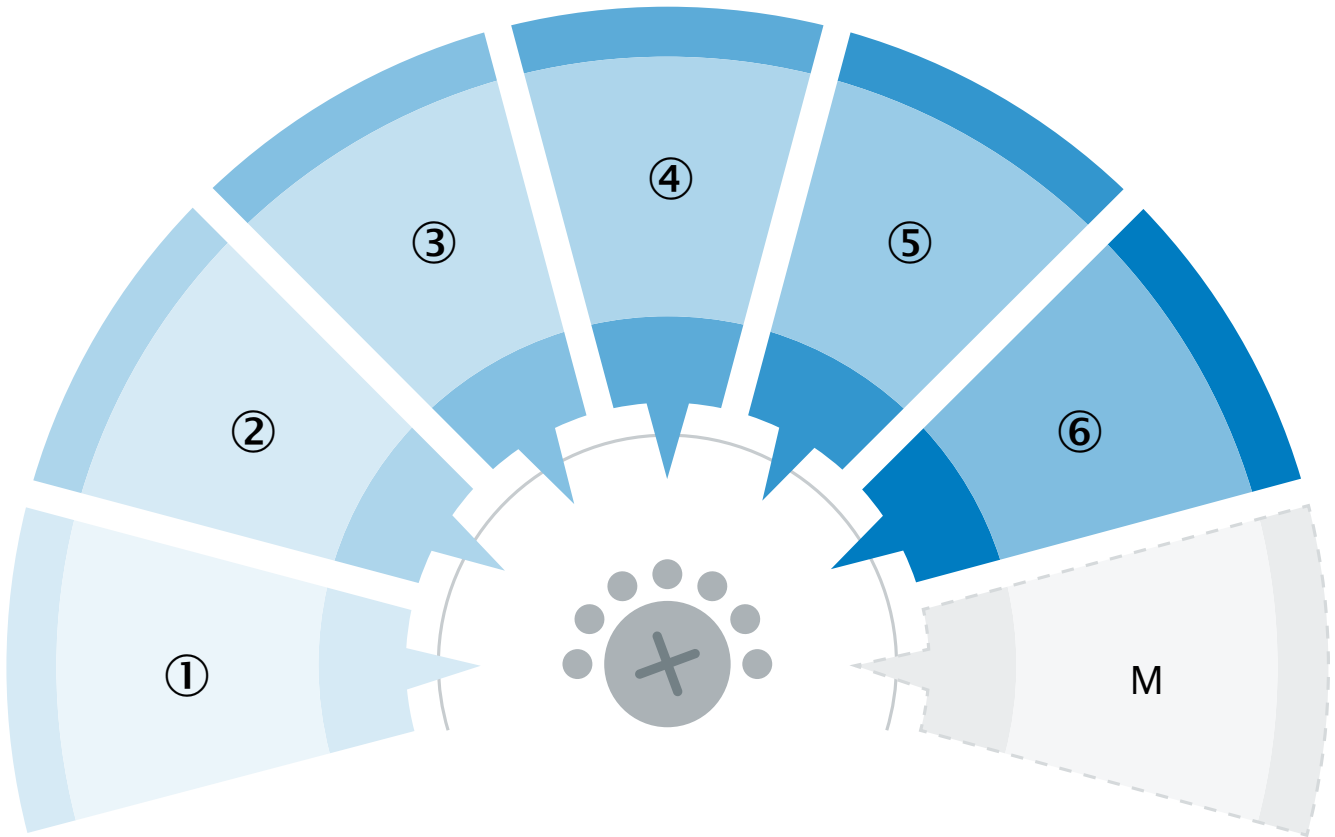

MultiMode settings	
1	Background suppression
2	Foreground suppression
3	Two Value Teach-in
4	Two independent switching points
5	Window Mode
6	ApplicationSelect
M	Manual / measurement

Connection diagram Cd-598 (Mode 1, 2, 3, 5, 6)

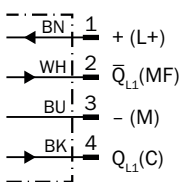

### Connection diagram Cd-597 (Mode 4)

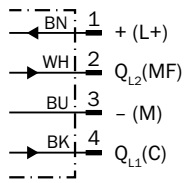

### Truth table Push-pull: PNP/NPN – dark switching $\bar{Q}$

	Dark switching $\bar{Q}$ (normally closed (upper switch), normally open (lower switch))	
	Object not present → Output HIGH	Object present → Output LOW
Light receive	✗	✓
Light receive indicator	✗	☀
Load resistance to L+	✗	⚡
Load resistance to M	⚡	✗

Truth table Push-pull: PNP/NPN - light switching Q

	Light switching Q (normally open (upper switch), normally closed (lower switch))	
	Object not present → Output LOW	Object present → Output HIGH
Light receive	⊗	☑
Light receive indicator	⊗	☀
Load resistance to L+	⚡	⊗
Load resistance to M	⊗	⚡

Characteristic curve Mode 2

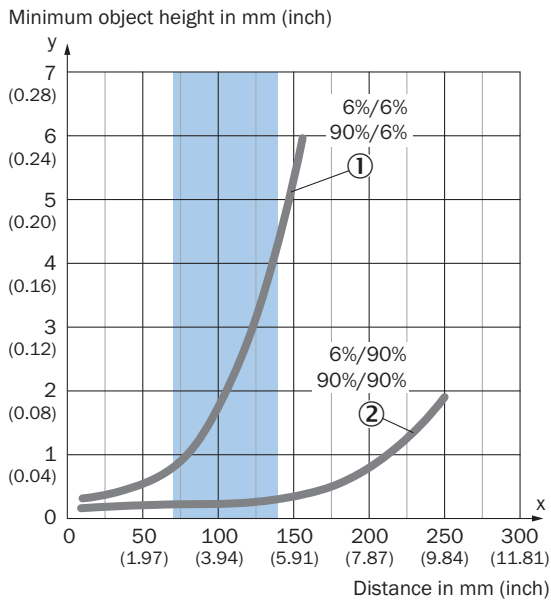

Recommended sensing range for the best performance

- ① Black background, 6% remission factor
- ② White background, 90% remission factor

Example:  
Reliable detection of the object

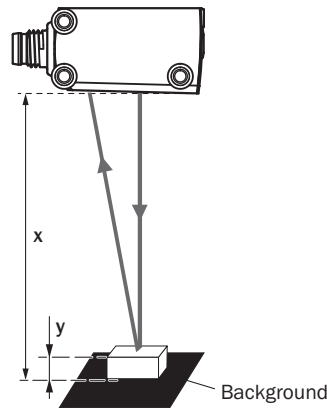

Black background (6 % remission factor)  
Distance of sensor to background  $x = 100$  mm  
Required minimum object height  $y = 1.9$  mm  
For all objects regardless of their colors

Characteristic curve Mode 1 and 6 combined

Minimum distance in mm (y) between the set sensing range and white background (90 % remission factor)

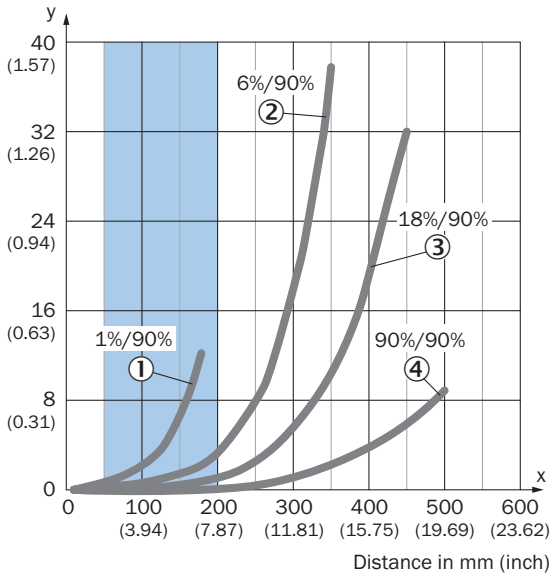

Recommended sensing range for the best performance

- ① ultra-black object, 1% remission factor
- ② Black object, 6% remission factor
- ③ Gray object, 18% remission factor
- ④ White object, 90% remission factor

Example:  
Safe suppression of the background

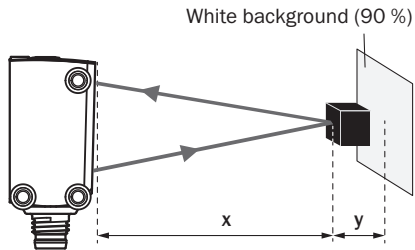

Black object (6 % remission factor)  
Set sensing range x = 300 mm  
Needed minimum distance to white background y = 17 mm

Characteristic curve Mode 1, 3, 4, 5

Minimum distance in mm (y) between the set sensing range and white background (90 % remission factor)

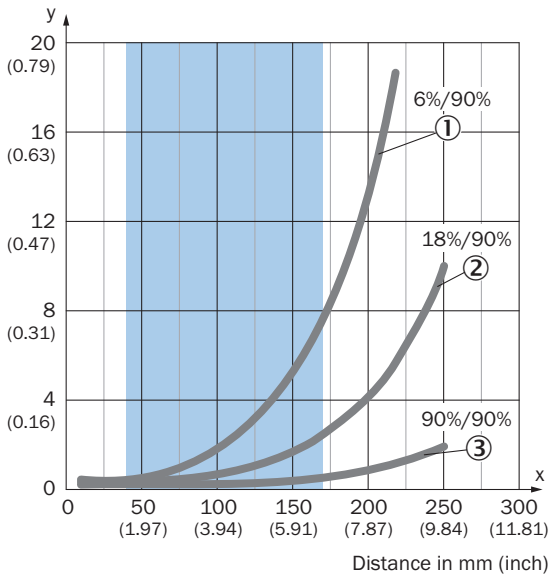

Recommended sensing range for the best performance

- ① Black object, 6% remission factor

Example:  
Safe suppression of the background

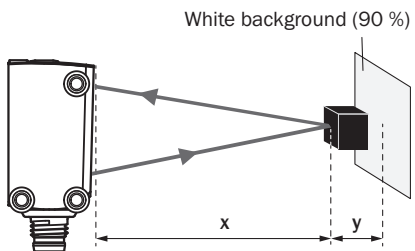

Black object (6 % remission factor)  
Set sensing range x = 150 mm  
Needed minimum distance to white background y = 5.5 mm

- ② Gray object, 18% remission factor
- ③ White object, 90% remission factor

### Light spot size Mode 2

Dimensions in mm (inch)

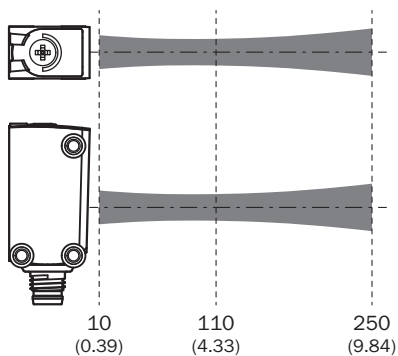
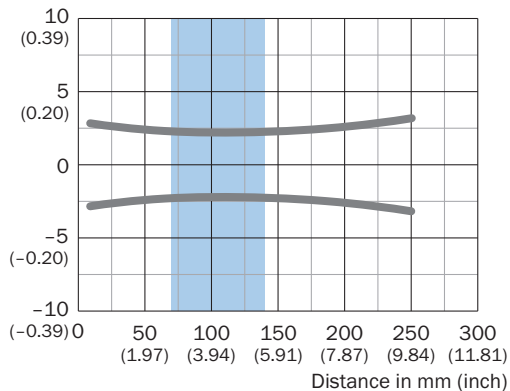

Recommended sensing range for the best performance

### Light spot size Mode 1 and 6 combined

Dimensions in mm (inch)

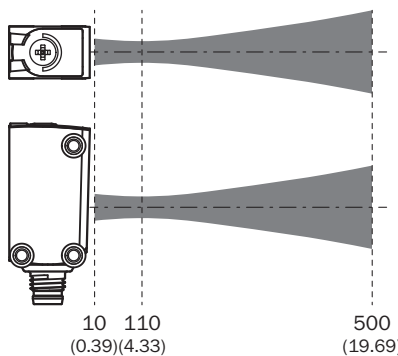
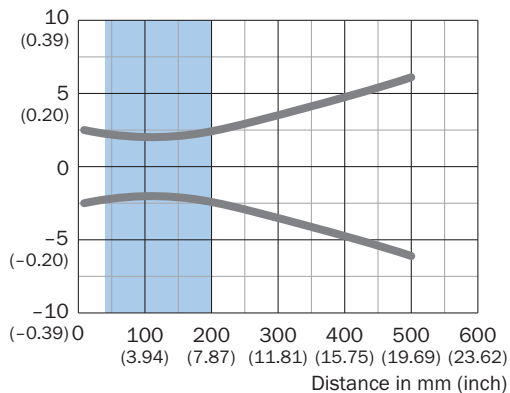

Recommended sensing range for the best performance

Light spot size Mode 1, 3, 4, 5

Dimensions in mm (inch)

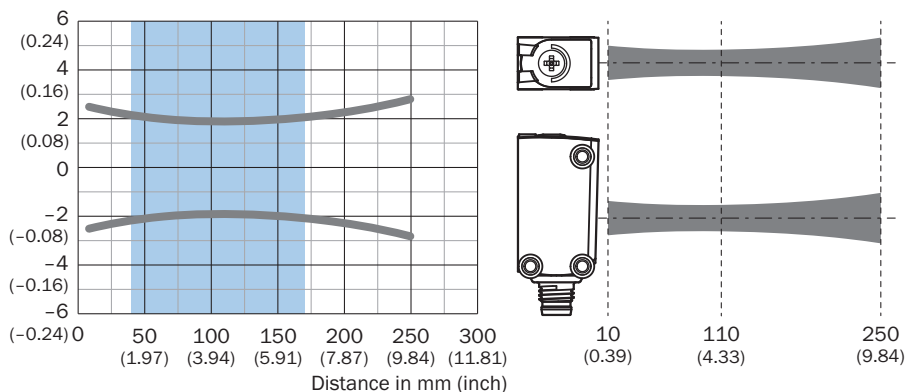

Recommended sensing range for the best performance

Sensing range diagram Mode 2

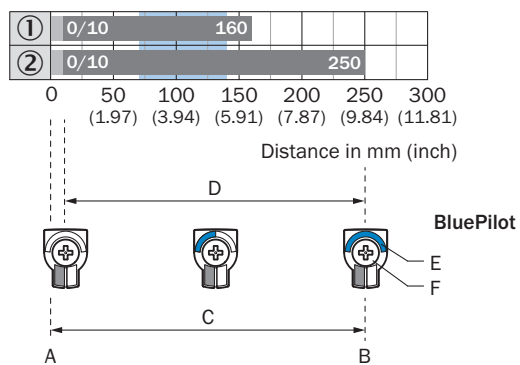

Recommended sensing range for the best performance

1	Black background, 6% remission factor
2	White background, 90% remission factor
A	Sensing range min. in mm
B	Sensing range max. in mm
C	Field of view
D	Adjustable switching threshold for foreground suppression
E	Sensing range indicator
F	Teach-Turn adjustment

### Sensing range diagram Mode 1 and 6 combined

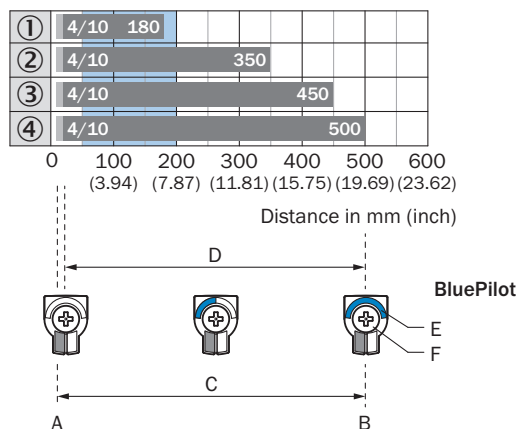

Recommended sensing range for the best performance

1	Ultra-black object, 1% remission factor
2	Black object, 6% remission factor
3	Gray object, 18% remission factor
4	White object, 90% remission factor
A	Sensing range min. in mm
B	Sensing range max. in mm
C	Field of view
D	Adjustable switching threshold for background suppression
E	Sensing range indicator
F	Teach-Turn adjustment

### Sensing range diagram Mode 1, 3, 4, 5

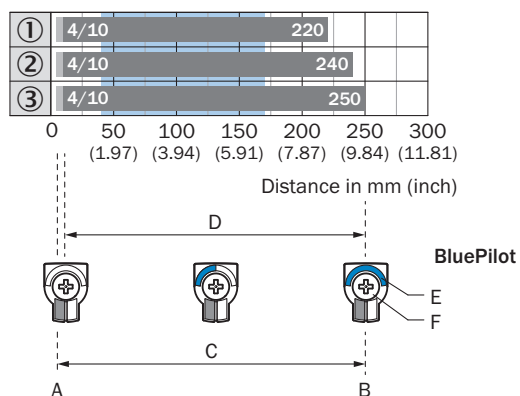

Recommended sensing range for the best performance

1	Black object, 6% remission factor
2	Gray object, 18% remission factor

3		White object, 90% remission factor
A		Sensing range min. in mm
B		Sensing range max. in mm
C		Field of view
D		Adjustable switching threshold for background suppression
E		Sensing range indicator
F		Teach-Turn adjustment

### Dimensional drawing, sensor

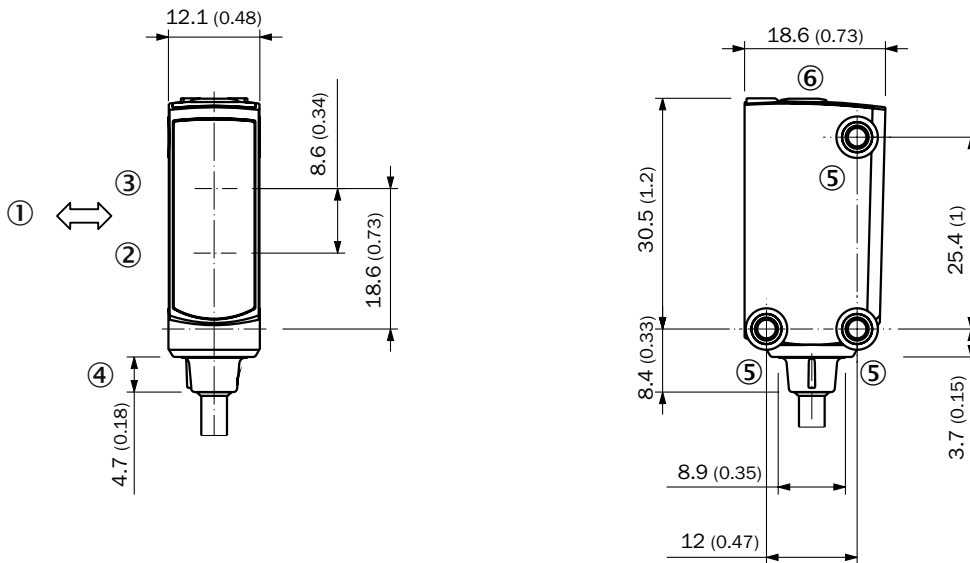





Dimensions in mm (inch)

- ① Standard direction of the material being detected
- ② Center of optical axis, receiver
- ③ Center of optical axis, sender
- ④ Connection
- ⑤ M3 mounting hole
- ⑥ display and adjustment elements

Recommended accessories

Other models and accessories → [www.sick.com/W4](http://www.sick.com/W4)

	Brief description	Type	part no.
<b>Mounting systems</b>			
	<ul style="list-style-type: none"> <li><b>Description:</b> Plate N08 for universal clamp bracket</li> <li><b>Material:</b> Steel, zinc diecast</li> <li><b>Details:</b> Zinc plated steel (sheet), Zinc die cast (clamping bracket)</li> <li><b>Items supplied:</b> Universal clamp (5322626), mounting hardware</li> <li><b>Usable for:</b> W100, W150, W4S, W4F, W8, W9-3, W8G, W8 Laser, W8 Inox, G6, W100 Laser, W100-2, W10, G6 Inox, RAY10, W4SLG-3, W9, GR18, MultiPulse, Reflex Array, MultiLine, LUT3, KT5, KT8, KT10, CS8</li> </ul>	BEF-KHS-N08	2051607
	<ul style="list-style-type: none"> <li><b>Material:</b> Stainless steel</li> <li><b>Details:</b> Stainless steel (1.4301)</li> <li><b>Suitable for:</b> W4S, W4S</li> </ul>	BEF-WN-G6	2062909
<b>connectors and cables</b>			
	<ul style="list-style-type: none"> <li><b>Description:</b> Sensor/actuator cable, unshielded</li> <li><b>Connection type head A:</b> Female connector, M12, 4-pin, straight, A-coded</li> <li><b>Connection type head B:</b> Flying leads</li> <li><b>Signal type:</b> Sensor/actuator cable</li> <li><b>Cable:</b> 5 m, 4-wire, PVC</li> <li><b>Application:</b> Uncontaminated zones, Zones with chemicals</li> </ul>	YF2A14-050VB3XLEAX	2096235
	<ul style="list-style-type: none"> <li><b>Description:</b> Sensor/actuator cable, unshielded</li> <li><b>Connection type head A:</b> Female connector, M12, 4-pin, straight, A-coded</li> <li><b>Connection type head B:</b> Flying leads</li> <li><b>Signal type:</b> Sensor/actuator cable</li> <li><b>Cable:</b> 5 m, 4-wire, PUR, halogen-free</li> <li><b>Application:</b> Drag chain operation, Zones with oils and lubricants, Robot, Drag chain operation</li> </ul>	YF2A14-050UB3XLEAX	2095608
	<ul style="list-style-type: none"> <li><b>Description:</b> Unshielded</li> <li><b>Connection type head A:</b> Male connector, M12, 4-pin, straight, A-coded</li> <li><b>Connection systems:</b> Screw-type terminals</li> <li><b>Permitted cross-section:</b> ≤ 0.75 mm<sup>2</sup></li> </ul>	STE-1204-G	6009932

## SICK AT A GLANCE

SICK is one of the leading manufacturers of intelligent sensors and sensor solutions for industrial applications. A unique range of products and services creates the perfect basis for controlling processes securely and efficiently, protecting individuals from accidents and preventing damage to the environment.

We have extensive experience in a wide range of industries and understand their processes and requirements. With intelligent sensors, we can deliver exactly what our customers need. In application centers in Europe, Asia and North America, system solutions are tested and optimized in accordance with customer specifications. All this makes us a reliable supplier and development partner.

Comprehensive services complete our offering: SICK LifeTime Services provide support throughout the machine life cycle and ensure safety and productivity.

For us, that is “Sensor Intelligence.”

## WORLDWIDE PRESENCE:

Contacts and other locations –[www.sick.com](http://www.sick.com)