

SICK.COM

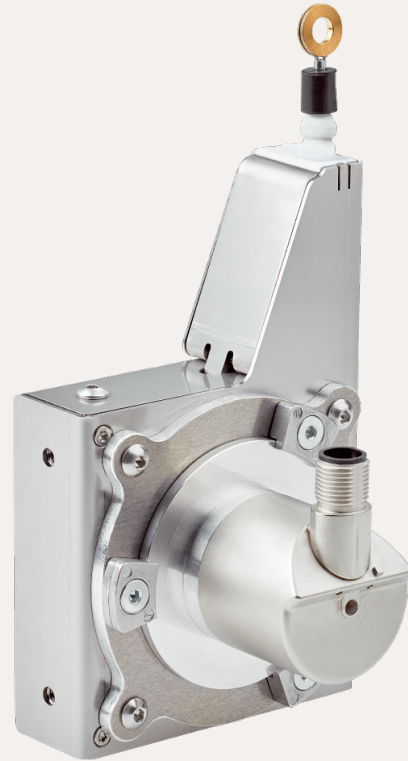

DATA SHEET

# BCV08-J1QM03M200

VarioLine  
Wire draw encoders

**SICK** Sensor Intelligence

## WIRE DRAW ENCODERS

BCV08-  
J1QM03M200

## ORDERING INFORMATION

Type	part no.
BCV08-J1QM03M200	<a href="#">1133458</a>

Further device versions and accessories at [www.sick.com/VarioLine](http://www.sick.com/VarioLine)



## DETAILED TECHNICAL DATA

## SAFETY-RELATED PARAMETERS

MTTF <sub>D</sub> (mean time to dangerous failure)	270 years (EN ISO 13849-1) <sup>1)</sup>
--	--

<sup>1)</sup> This product is a standard product and does not constitute a safety component as defined in the Machinery Directive. Calculation based on nominal load of components, average ambient temperature 40°C, frequency of use 8760 h/a. All electronic failures are considered hazardous. For more information, see document no. 8015532.

## PERFORMANCE

Measurement range	0 m ... 3 m
Encoder	Absolute encoders
Resolution (wire draw + encoder)	0.01 mm <sup>1) 2)</sup>
Repeatability	≤ 0.3 mm <sup>3)</sup>
Linearity	≤ ± 2 mm <sup>3)</sup>
Hysteresis	≤ 1.2 mm <sup>3)</sup>

<sup>1)</sup> The values shown have been rounded.

<sup>2)</sup> Example calculation based on the BCV08 with PROFINET: 230 mm (wire draw length per revolution - see Mechanical data); 262,144 (number of steps per revolution) = 0.001 mm (resolution of wire draw + encoder combination).

<sup>3)</sup> Value applies to wire draw mechanism.

## INTERFACES

Communication interface	SAE J1939
Programmable/configurable	✓

**ELECTRONICS**

Connection type	Male connector, M12, 5-pin, universal
Supply voltage	10 V ... 30 V
Power consumption	≤ 1.5 W (without load)

**MECHANICS**

Weight	0.72 kg
Measuring wire material	Stainless steel 1.4401
Measuring wire diameter	0.81 mm
Housing material, wire draw mechanism	Stainless steel 1.4301
Spring return force	8 N ... 10 N <sup>1)</sup>
Length of wire pulled out per revolution	230 mm
Life of wire draw mechanism	Typ. 1,000,000 cycles <sup>2) 3)</sup>
Actual wire draw length	3.2 m
Operating speed	4 m/s
Mounted encoder	AHM36 SAE J1939, AHM36A-S3JC014X12, 1120251
Mounted mechanic	MRA-V080-103D3, 5347779

<sup>1)</sup> These values were measured at an ambient temperature of 25 °C. There may be variations at other temperatures.

<sup>2)</sup> Average values, which depend on the application.

<sup>3)</sup> The service life depends on the type of load. This is influenced by environmental conditions, the installation location, the measuring range in use, the traversing speed, and acceleration.

**AMBIENT DATA**

EMC	According to EN 61000-6-2 and EN 61000-6-3
Enclosure rating	IP60, mounted mechanic IP66, Encoder (IEC 60529) IP67, Encoder (IEC 60529)
Operating temperature range	-30 °C ... +70 °C

**CERTIFICATES**

EU declaration of conformity	✓
UK declaration of conformity	✓
ACMA declaration of conformity	✓
Moroccan declaration of conformity	✓
China RoHS	✓

**DIMENSIONAL DRAWING**

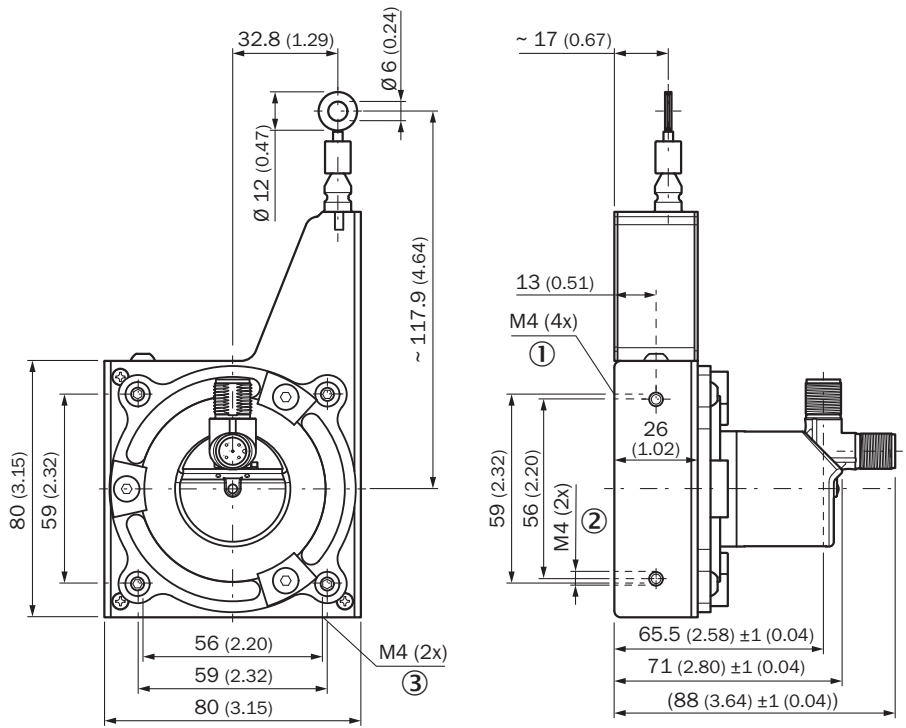

Dimensions in mm (inch)

**ANSCHLUSSBELEGUNG**

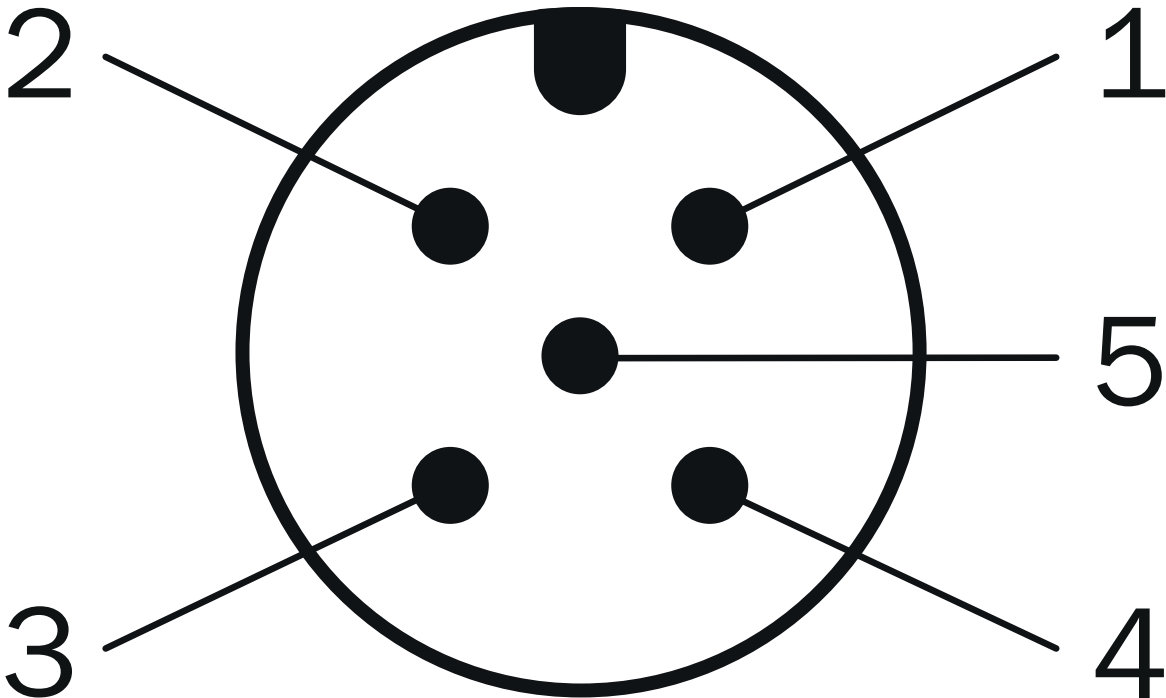

PIN	Signal	Wire colors (cable connection)	Function
1	CAN Shield	White	Shielding
2	VDC	Red	Supply voltageEncoder 10 V DC ... 30 V DC
3	GND/CAN GND	Blue	0 V (GND)
4	CAN high	Black	CAN signal
5	CAN low	Pink	CAN signal
Housing	-	-	Shielding

Further information as well as suitable accessories, example applications and downloads such as CAD dimensional models, operating instructions and software can be found at [www.sick.com/1133458](http://www.sick.com/1133458)



SICK AG  
WALDKIRCH  
GERMANY  
SICK.COM

# SICK AT A GLANCE

SICK is a leading global technology company for intelligent sensors and integrated solutions in industrial automation. Our technologies set benchmarks, making your industrial processes more efficient, safer and more sustainable – both in logistics and manufacturing operations.

SICK combines sensor intelligence with industry expertise and certified consulting services. We provide the ideal foundation for scalable as well as tailor-made automation solutions and create added value along the entire value chain. Our close partnerships with our customers are more than just a promise: Together, we optimize productivity, improve quality, protect health and safety, and help build a sustainable future. All with empathy and trust.

Since 1946, we have been developing innovative technologies with passion and a pioneering spirit. With a global network in around 40 countries, SICK has a global presence and is always close by. The company's headquarters are located in Waldkirch near Freiburg, Germany. Our customers benefit from our understanding of both local and global requirements, which enables us to deliver tailor-made solutions

**SICK**  
Sensor Intelligence