

SICK.COM



DATA SHEET

DAXTAN-0500RA1J0100E00

DAX
Magnetostrictive linear encoders

SICK Sensor Intelligence

MAGNETOSTRICTIVE LINEAR ENCODERS

DAX-
TAN-0500RA1J0100E00

ORDERING INFORMATION

Type	part no.
DAXTAN-0500RA1J0100E00	1130901

Further device versions and accessories at www.sick.com/DAX



Illustration may differ

DETAILED TECHNICAL DATA

SAFETY-RELATED PARAMETERS

MTTF _D (mean time to dangerous failure)	123 years ¹⁾
--	-------------------------

¹⁾ This product is a standard product and does not constitute a safety component as defined in the Machinery Directive. Calculation based on nominal load of components, average ambient temperature 40°C, frequency of use 8760 h/a. All electronic failures are considered hazardous. For more information, see document no. 8015532.

PERFORMANCE

Linearity	≤ 0.02% F.S. (Minimum 60 μm) ^{1) 2)}	
Repeatability	≤ ± 20 μm	
Measured values	Positioning	
Measuring range	0 mm ... 500 mm	
Unusable range	Null zone	50 mm
	Damping zone	63 mm
Magnet type	Magnet shape	Ring magnet
	Configured for number of magnets	1 piece
Magnet travel speed	Any	
Measuring frequency (internal)	< 2 ms	

¹⁾ Systematic position measurement deviation according to DIN ISO 1319-1 (value includes all systematic errors or deviations from the actual position value, e.g. repeatability and hysteresis).

²⁾ In principle, the size of the measurement deviation is limited by the resolution of the interface.

INTERFACES

Communication interface	-	
Communication Interface detail	Current	
Output signal	4 mA ... 20 mA	
Signals	Number of signals	Two output signals (one output signal + an inverted second output signal)
	Sequence of signals	Signal 1: rising, signal 2: falling
Load resistance	100 Ω ... 500 Ω	

ELECTRONICS

Connection type	Male connector, M12, 5-pin	
Pinouts	1=+24 V DC; 2=Signal 1; 3=Power ground; 4=Signal 2; 5=Output signal ground (0 V)	
Male connector coding	A-coded	
Supply voltage	24 V DC (± 20%)	
Current consumption	50...100 mA	
Reverse polarity protection	Up to -30 V DC	
Residual ripple	≤ 0.28 V _{pp}	
Dielectric strength	500 V DC, 0 V against housing	
Over voltage protection	≤ 36 V DC	

MECHANICS

Mechanical design	DAX Threaded	
Thread	Thread shape	M18 x 1.5
	Thread offset	Without thread offset
Material	Pressure pipe	Stainless steel 1.4404 (AISI 316L)
	Housing	Aluminum (anodised), zinc, stainless steel, brass
	Flange	Stainless steel 1.4305 (AISI 303)

AMBIENT DATA

EMC	According to EN 61000-6-2 and EN 61000-6-4	
Enclosure rating	IP65, IP67 ¹⁾	
Temperature	Operating temperature range	-40 °C ... +85 °C
	Storage temperature range	-40 °C ... +65 °C ²⁾
Permissible relative humidity	90 % (Condensation not permitted)	
Resistance to shocks	100 g, 6 ms (IEC 60068-2-27)	
Resistance to vibration	15 g / 10...2,000 Hz according to IEC 60068-2-6	
Nominal operating pressure (P _N)	350 bar	
Max. overload pressure during operation (P _N x 1.2)	420 bar	
Max. test pressure in cylinder (P _N x 1.5)	530 bar	

¹⁾ In correctly assembled mating connector.

²⁾ Caused by dry storage of the O-ring in uninstalled state (no coating with oil).

GENERAL NOTES

Items supplied	Accessories not included with delivery, please order separately. Delivery without position magnet.
----------------	---

CERTIFICATES

EU declaration of conformity	✓
UK declaration of conformity	✓
ACMA declaration of conformity	✓
Moroccan declaration of conformity	✓
China RoHS	✓
cULus certificate	✓
Information according to Art. 3 of Data Act (Regulation EU 2023/2854)	✓

DIMENSIONAL DRAWING RING MAGNET MAG-O-330-01 (2129167)

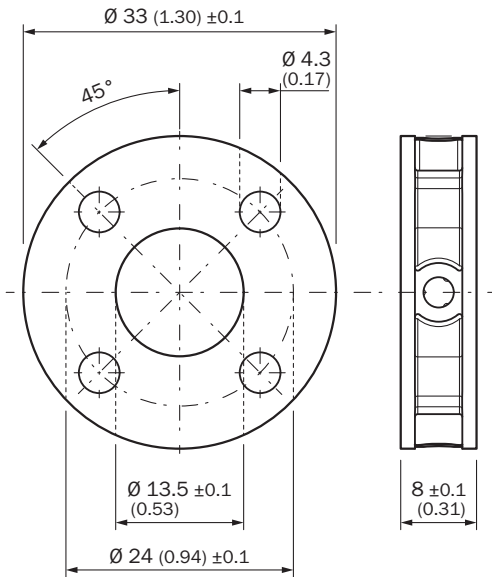

Dimensions in mm (inch)

DAX THREADED

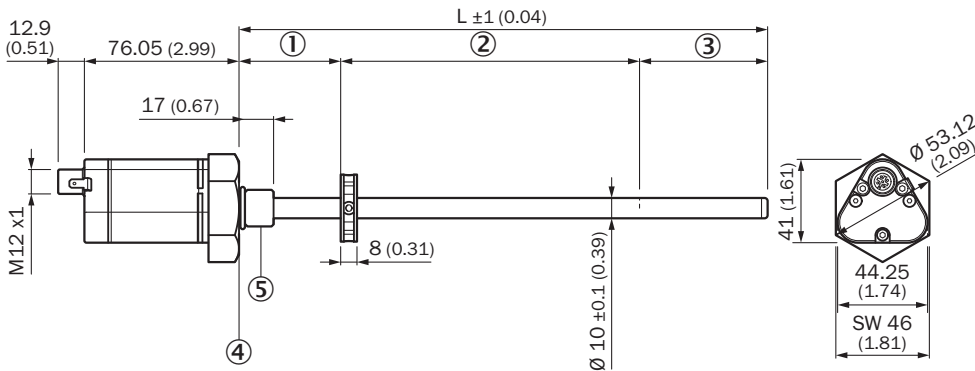

Dimensions in mm (inch)

- ① null zone
- ② Measuring range
- ③ damping zone
- ④ Flat support surface
- ⑤ M18x1.5 / UNF 3/4"-16

ANSCHLUSSBELEGUNG

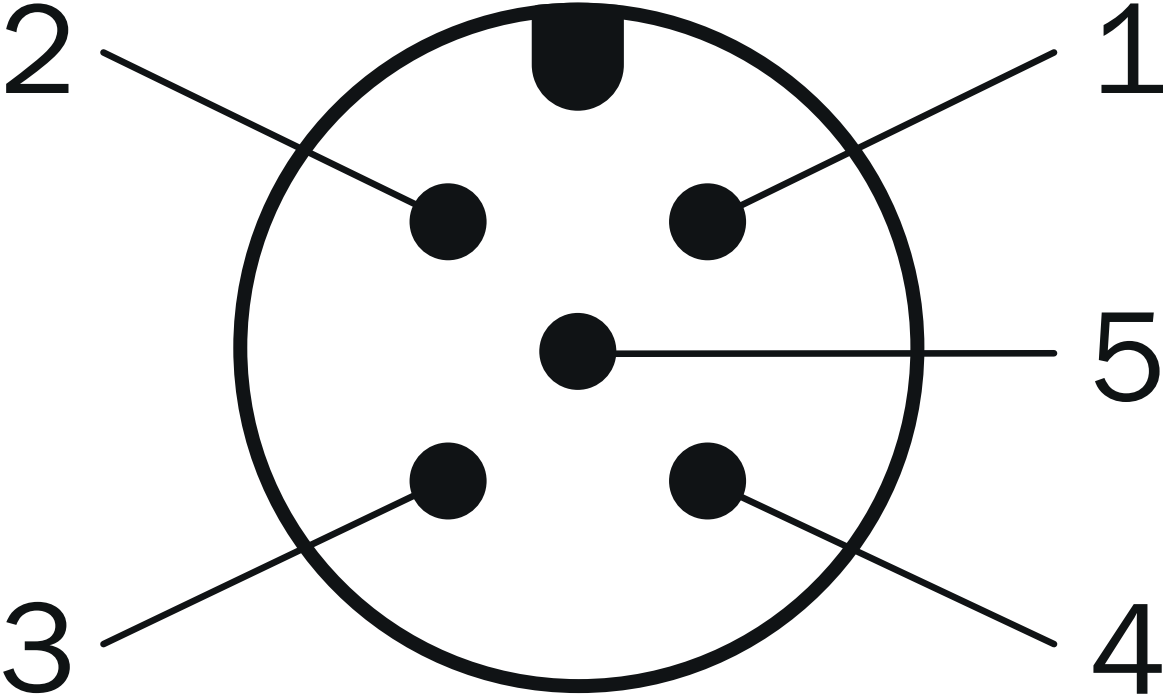

Plug, M12, 5-pin	Signal
1	+24 V DC
2	Signal 1
3	Power Ground
4	Signal 2
5	Output signal ground (0 V)

Further information as well as suitable accessories, example applications and downloads such as CAD dimensional models, operating instructions and software can be found at www.sick.com/1130901



SICK AG
WALDKIRCH
GERMANY
SICK.COM

SICK AT A GLANCE

SICK is a leading global technology company for intelligent sensors and integrated solutions in industrial automation. Our technologies set benchmarks, making your industrial processes more efficient, safer and more sustainable – both in logistics and manufacturing operations.

SICK combines sensor intelligence with industry expertise and certified consulting services. We provide the ideal foundation for scalable as well as tailor-made automation solutions and create added value along the entire value chain. Our close partnerships with our customers are more than just a promise: Together, we optimize productivity, improve quality, protect health and safety, and help build a sustainable future. All with empathy and trust.

Since 1946, we have been developing innovative technologies with passion and a pioneering spirit. With a global network in around 40 countries, SICK has a global presence and is always close by. The company's headquarters are located in Waldkirch near Freiburg, Germany. Our customers benefit from our understanding of both local and global requirements, which enables us to deliver tailor-made solutions

SICK
Sensor Intelligence