

SICK.COM



DATA SHEET

PLB-5350100

PLB
Robot guidance systems

SICK Sensor Intelligence

ROBOT GUIDANCE SYSTEMS

PLB-5350100

ORDERING INFORMATION

Type	part no.
PLB-5350100	1129627

Further device versions and accessories at www.sick.com/PLB



DETAILED TECHNICAL DATA

FEATURES

Product version	PLB-515
Field of view	Large
Classification	Prime
Tasks	Position determination
Applications	Robot guidance
Camera type	3D snapshot
Example volume of view (L x W x H)	600 mm x 500 mm x 500 mm
Image resolution	0.38 mm ... 1.36 mm, depending on the distance to the camera
Light source	LED, blue, 465 nm
LED class	Risk group 0 (Exempt, IEC62471 : 2006)
Localization principle	Geometrical shape and edge localization
Technology	3D snapshot, image analysis

MECHANICS/ELECTRONICS

Connection type	M9 male connector, 7-pin
Supply voltage	12 V ... 24 V, Or PoE Class 3
Current consumption	2 A
Dimensions (L x W x H)	192 mm x 50 mm x 52 mm
Weight	650 g
Enclosure rating	IP65 / IP67

PERFORMANCE

Part localization time	3 s ... 10 s, typical
Part size	(approx.) > 50 mm x 50 mm x 50 mm
Part characteristics	Simple and complex part shapes

INTERFACES

Ethernet	Data transmission rate	1 Gbit/s (camera), 10/100 Mbit/s (robot)
	Protocol	TCP/IP (camera)
	Electrical connection	RJ45

AMBIENT DATA

Ambient temperature, operation	0 °C ... +40 °C, Non-condensing
Shock load	80 g/1,9 ms, 25 g / 6 ms ¹⁾
Vibration load	30-500 Hz / 10 g ²⁾

¹⁾ IEC 60068-2-27.²⁾ IEC 60068-2-6.**GENERAL NOTES**

Items supplied	N36 camera PLB Application Software
Factory calibrated	✓

CERTIFICATES

ACMA declaration of conformity	✓
China RoHS	✓
Information according to Art. 3 of Data Act (Regulation EU 2023/2854)	✓

DIMENSIONAL DRAWING

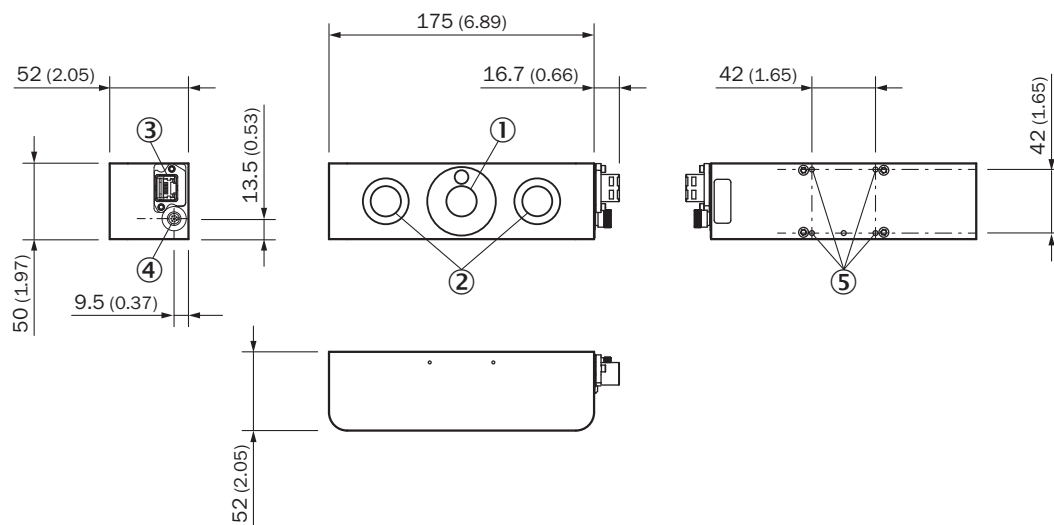

Dimensions in mm (inch)

- ① LED projection module
- ② Image sensor
- ③ Ethernet (RJ45)
- ④ Power / I/O (Binder 712, 7-pin)
- ⑤ Fastening threads (4x M4 x 0.7 mm, 8 mm deep)

Further information as well as suitable accessories, example applications and downloads such as CAD dimensional models, operating instructions and software can be found at www.sick.com/1129627



SICK AG
WALDKIRCH
GERMANY
SICK.COM

SICK AT A GLANCE

SICK is a leading global technology company for intelligent sensors and integrated solutions in industrial automation. Our technologies set benchmarks, making your industrial processes more efficient, safer and more sustainable – both in logistics and manufacturing operations.

SICK combines sensor intelligence with industry expertise and certified consulting services. We provide the ideal foundation for scalable as well as tailor-made automation solutions and create added value along the entire value chain. Our close partnerships with our customers are more than just a promise: Together, we optimize productivity, improve quality, protect health and safety, and help build a sustainable future. All with empathy and trust.

Since 1946, we have been developing innovative technologies with passion and a pioneering spirit. With a global network in around 40 countries, SICK has a global presence and is always close by. The company's headquarters are located in Waldkirch near Freiburg, Germany. Our customers benefit from our understanding of both local and global requirements, which enables us to deliver tailor-made solutions

SICK
Sensor Intelligence