



RMS2831C-636011

RMS2000

RADAR SENSORS

SICK
Sensor Intelligence.



Ordering information

Type	part no.
RMS2831C-636011	1129090

Other models and accessories → www.sick.com/RMS2000

Detailed technical data

Features

Application	Outdoor, Indoor
Variant	Model RMS-C
Measurement principle	FMCW
Radio approval	Japan
Frequency band	60.5 GHz ... 61 GHz
Transmitting power	≤ 100 mW (e.i.r.p.)
Aperture angle	Horizontal ± 60°
	Vertical ± 4°
Angular accuracy (azimuth)	1.5°
Angular resolution (azimuth)	15°
Working range	1.6 m ... 200 m
Scanning range	For 1 m ² RCS 50 m
	At 10 m ² RCS 200 m
Distance accuracy	1 m ² RCS to 20 m 0.16 m
	1 m ² RCS to 50 m 0.4 m
Distance resolution	1.6 m ¹⁾
Speed range	± 60 m/s
Speed resolution	0.625 m/s ¹⁾
Speed accuracy	1 m ² RCS to 20 m 0.0625 m/s
	1 m ² RCS to 50 m 0.15 m/s

¹⁾ Resolution in the context of radar means that two signals can be separated if they differ in spacing, angle or speed by more than twice the specified values.

Mechanics/electronics

Connection type	1 x M12 male connector, 8-pin, A-coded 1 x male connector M12, 5-pin, A-coded 1 x M12 female connector, 4-pin, D-coded
------------------------	--

Supply voltage	9 V DC ... 32 V DC
Power consumption	Typ. 4 W, For digital outputs without load, max. 36 W
Housing color	Gray (RAL 7042)
Enclosure rating	IP67 IP69
Protection class	III
Weight	300 g
Dimensions (L x W x H)	34 mm x 97 mm x 96 mm
MTBF	81 years
MTTFd	> 100 years

Safety-related parameters

MTTF_D	> 100 years
-------------------------	-------------

Performance

Initialization time	Typ. 20 s
Processing latency	1 measurement cycle
Measurement cycle duration	100 ms
Integrated application	Zone evaluation
Number of field sets	Up to 4 zones

Interfaces

Ethernet	✓
Function	Parameterization, Data output
Data transmission rate	10/100 MBit/s
Digital inputs	2 (digital)
Digital outputs	4 (digital)

Ambient data

Electromagnetic compatibility (EMC)	ETSI EN 301 489-1 / EN 61000-6-2 / EN 61000-6-4
Radio standard	ETSI EN 305 550
Vibration resistance	EN 60068-2-6:2008-02
Shock resistance	EN 60068-2-27:2009-05
Ambient operating temperature	-40 °C ... +65 °C
Storage temperature	-40 °C ... +85 °C

Certificates

China RoHS	✓
cTUVus certificate	✓
Radio Approval certificate Japan	✓

Classifications

ECLASS 5.0	27270890
ECLASS 5.1.4	27270890
ECLASS 6.0	27270890

ECLASS 6.2	27270890
ECLASS 7.0	27270890
ECLASS 8.0	27270890
ECLASS 8.1	27270890
ECLASS 9.0	27270890
ECLASS 10.0	27270807
ECLASS 11.0	27270807
ECLASS 12.0	27274501
ETIM 5.0	EC001825
ETIM 6.0	EC001825
ETIM 7.0	EC001825
ETIM 8.0	EC001825
UNSPSC 16.0901	39121528

Dimensional drawing

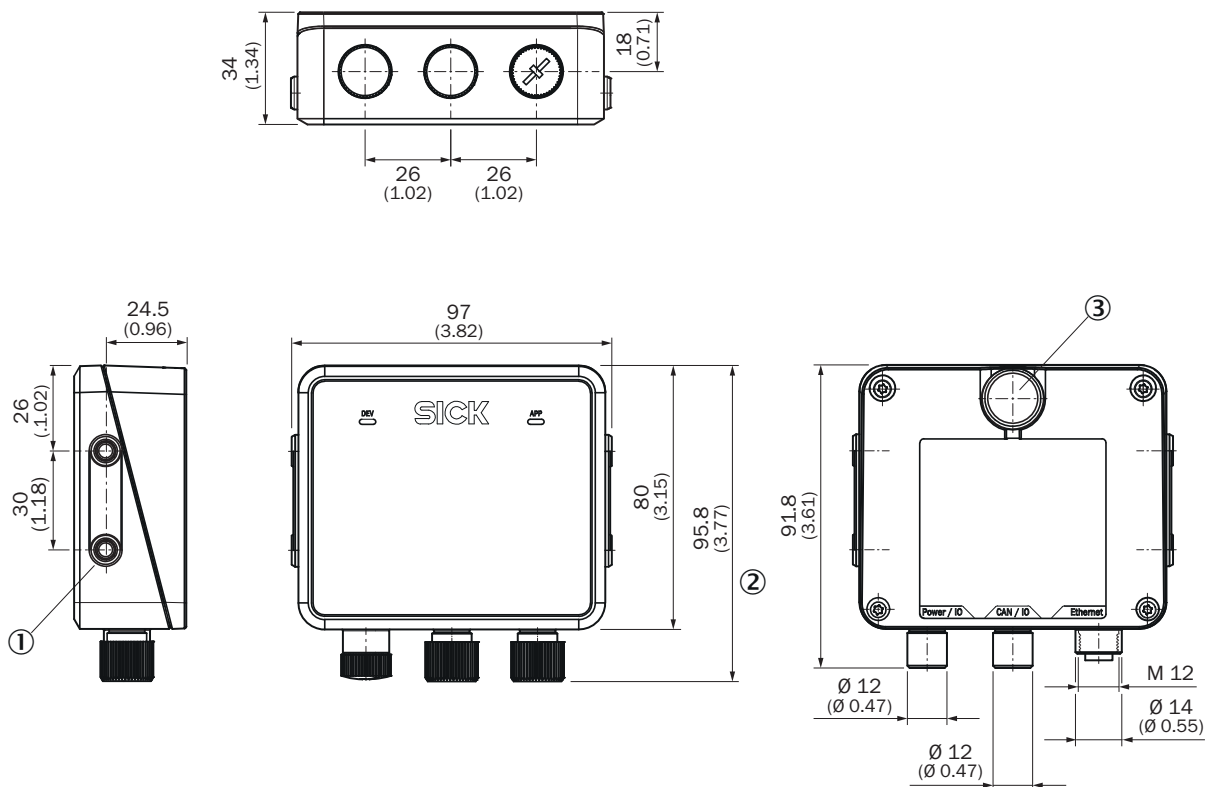

Dimensions in mm (inch)

structure and device dimensions, unit: mm (inch), decimal separator: period

- ① 4 x M5 blind tapped holes, 7.5 mm deep for mounting the device
- ② Dimension with protective cap mounted on the connections
- ③ Pressure compensation diaphragm

PIN assignment CAN

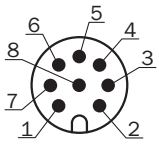

Connector M12, 8-pin, A-coded

- ① CAN_HI
- ② CAN_LO
- ③ In₂
- ④ GND IN1/2
- ⑤ OUT2
- ⑥ OUT3
- ⑦ GND
- ⑧ OUT4

PIN assignment Ethernet

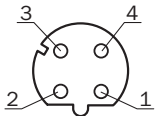

M12 female connector, 4-pin, D-coded

- ① TX+
- ② RX+
- ③ TX-
- ④ RX-

PIN assignment Power

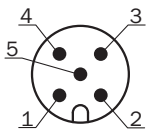

Connector M12, 5-pin, A-coded

- ① L+
- ② In₁
- ③ GND
- ④ OUT1
- ⑤ GND IN1/2

SICK AT A GLANCE

SICK is one of the leading manufacturers of intelligent sensors and sensor solutions for industrial applications. A unique range of products and services creates the perfect basis for controlling processes securely and efficiently, protecting individuals from accidents and preventing damage to the environment.

We have extensive experience in a wide range of industries and understand their processes and requirements. With intelligent sensors, we can deliver exactly what our customers need. In application centers in Europe, Asia and North America, system solutions are tested and optimized in accordance with customer specifications. All this makes us a reliable supplier and development partner.

Comprehensive services complete our offering: SICK LifeTime Services provide support throughout the machine life cycle and ensure safety and productivity.

For us, that is “Sensor Intelligence.”

WORLDWIDE PRESENCE:

Contacts and other locations –www.sick.com