



NCV50E-20CCP100004

SPEETEC 1D

NON-CONTACT MOTION SENSORS

SICK
Sensor Intelligence.



Illustration may differ

Ordering information

Type	part no.
NCV50E-20CCP100004	1128312

Other models and accessories → www.sick.com/SPEETEC_1D



Detailed technical data

Features

Specialty	<p>SPEETEC closes the gap between tactile measuring wheel systems and complex laser Doppler sensors – and is suitable for almost all surfaces and objects thanks to the non-contact measurement that uses no measuring elements. This opens up new fields of application in motion monitoring.</p> <p>NCV50E is the ideal solution for OEM customers who define the best mounting position for their application and can ensure precise mounting. The systematic errors of the application can be determined by performing a reference measurement after mounting. If this is not possible, the NCV50B model should be preferred.</p> <p>Non-contact measurement on moving objects without measuring elements. Class 1 laser</p>
------------------	--

Safety-related parameters

MTTFd: mean time to dangerous failure	33 years ¹⁾
--	------------------------

¹⁾ This product is a standard product and does not constitute a safety component as defined in the Machinery Directive. Calculation based on nominal load of components, average ambient temperature 40 °C, frequency of use 8760 h/a. All electronic failures are considered hazardous. For more information, see document no. 8015532.

System

Light source	1 continuous beam laser ¹⁾
Wave length	850 nm
Laser class	1 (IEC 60825-1:2014) ²⁾
Type of light	Invisible infrared light
Typ. measurement field size (distance)	2 mm x 1.5 mm (at 50 mm) 2 mm x 1.5 mm (at 45 mm) 2 mm x 1.5 mm (at 55 mm)
Laser power (per laser)	0.78 mW ³⁾

¹⁾ L10 ≥ 32,500 h (not temperature-dependent). The lasers are always on when the sensor is supplied with voltage. To increase the service life of the sensor, we recommend completely disconnecting the sensor from the voltage supply when it is not needed. No warranty claims relating to the reaching of the service life of the laser will be accepted.

²⁾ Do not intentionally look into the laser beam. Never point the laser beam at people's eyes.

³⁾ The device must not be operated if the screen is damaged or missing.

Performance

Nominal measuring distance	50 mm
Static mounting tolerance	Ca. ± 5 mm ¹⁾
Possible static measuring distance	30 ... 100 mm ²⁾
Direction of movement	1D, x-direction
Start/stop	Not recommended
Movement detection	Bidirectional
Measuring increment ($\mu\text{m}/\text{pulse}$)	4 (At 90° electrical)
Speed measuring range	> 0 m/s ... 10 m/s ³⁾
Permissible acceleration	≤ 30 m/s ²
Accuracy	
Measurement accuracy	0.72% ⁴⁾
Repeatability	0.1 % ⁵⁾
Internal sampling rate	330 μs
Latency	2.9 ms

¹⁾ Mounting the device closer than the specified measuring distance will not affect the accuracy of the measurement for suitable materials. Operation outside of the tolerance is possible with restrictions.

²⁾ The possible measuring distance depends on the material and must be identified in each case for the material used in the application, see the "Permissible measuring distance" table. The static mounting tolerance is included in the range mentioned above and is not additionally available.

³⁾ No continuous operation < 0.1 m/s recommended.

⁴⁾ Error limit for systematic measurement deviation in accordance with DIN 1319-1:1995. Valid between 0.2 m/s ... 10 m/s. The achievable measurement accuracy depends on the accuracy of installation. See "Permissible deviations from nominal alignment".

⁵⁾ Maximum permissible measurement deviation in accordance with DIN 1319-1:1995 under constant conditions. Valid between 0.2 m/s ... 10 m/s, averaged over 0.25 m measuring length.

Electronics

Supply voltage	12 V ... 30 V
Communication interface	TTL / HTL
Factory setting	Factory setting: output level TTL
Output frequency	≤ 625 kHz
Connection type	Male connector, M12, 8-pin, A-coded ¹⁾
Parameterization and diagnostic interface with digital input and output	Yes
Parameterising data	TTL or HTL electrical interface Length of the measuring step Direction of movement forward or backward Functionality of the digital inputs and outputs Logic function "Deactivate incremental signal" Logic function "Digital trigger output active after defined length" Customer correction factor to compensate for assembly tolerances
Available diagnostics data	Operating hour counter Sensor temperature Current speed value Current signal-to-noise ratios Indicators for measurement errors due to reflections State of the digital inputs and outputs

¹⁾ Observe the maximum length of cable: e.g. 20 m at a resolution of 4 μm and 1 m/s or 2 m at a resolution of 4 μm and 5 m/s: The frequency is calculated differentially with 4-fold evaluation as follows: Frequency = (speed/resolution) / 4; Example: (5.0 m/s / 4 μm) / 4 = 312.5 kHz; maximum frequency 625 kHz.

²⁾ Short-circuit to another channel or GND permissible for a maximum of 30 s. No protection in the case of a short-circuit channel of U_S.

³⁾ Digital output DO can have an undefined state during this time.

Power consumption	< 8 W
Load current	≤ 30 mA, per channel
Reverse polarity protection	✓
Protection class	III according to DIN EN 61140
Short-circuit resistant outputs	✓ ²⁾
Initialization time	Max. 3 s ³⁾

¹⁾ Observe the maximum length of cable: e.g. 20 m at a resolution of 4 μm and 1 m/s or 2 m at a resolution of 4 μm and 5 m/s: The frequency is calculated differentially with 4-fold evaluation as follows: Frequency = (speed/resolution) / 4; Example: (5.0 m/s / 4 μm) / 4 = 312.5 kHz; maximum frequency 625 kHz.

²⁾ Short-circuit to another channel or GND permissible for a maximum of 30 s. No protection in the case of a short-circuit channel of U_S.

³⁾ Digital output DO can have an undefined state during this time.

Mechanics

Dimensions	140 mm x 95 mm x 32.5 mm (without plug)	
Weight	400 g	
Material	Housing	Aluminum
	Screen	PMMA
	Plug insert	PA66, copper-zinc alloy (CuZn)
Permissible angle	Permissible pitch angle	≤ ± 0.2° ¹⁾
	Permissible yaw angle	≤ ± 1.5° ¹⁾
	Permissible roll angle	≤ ± 10° ¹⁾

¹⁾ Exceeding these values will result in a higher systematic measurement error, see "Permissible deviations from nominal alignment".

Ambient data

EMC	EN 61000-6-2, EN 61000-6-3	
Enclosure rating	IP65 (EN 60529) ¹⁾	
	IP67 (EN 60529) ¹⁾	
Permissible relative humidity	70 % ²⁾	
Temperature	Operating temperature range	0 °C ... +45 °C ³⁾
	Storage temperature range	-32 °C ... +60 °C, without package
Resistance	Resistance to shocks	30 g, 6 ms (EN 60068-2-27)
	Resistance to vibration	20 g, 10 Hz ... 2,000 Hz (EN 60068-2-6)

¹⁾ For suitable mating connector and correct mounting of the mating connector.

²⁾ Condensation on laser modules and screen not permitted.

³⁾ If the permissible temperature range is exceeded, the sensor switches off the laser to protect it against damage. No signal is outputted in this case. The variant with parameterization and diagnostic functions offers the option of monitoring the internal temperature and therefore the reserves up until the point of switching off.

Certificates

EU declaration of conformity	✓
UK declaration of conformity	✓
ACMA declaration of conformity	✓
Moroccan declaration of conformity	✓

China RoHS	✓
cULus certificate	✓
Information according to Art. 3 of Data Act (Regulation EU 2023/2854)	✓

Classifications

ECLASS 5.0	27270790
ECLASS 5.1.4	27270790
ECLASS 6.0	27270790
ECLASS 6.2	27270790
ECLASS 7.0	27270790
ECLASS 8.0	27270790
ECLASS 8.1	27270790
ECLASS 9.0	27270790
ECLASS 10.0	27270790
ECLASS 11.0	27270790
ECLASS 12.0	27275201

Dimensional drawing Side view with threaded holes for proximity sensors

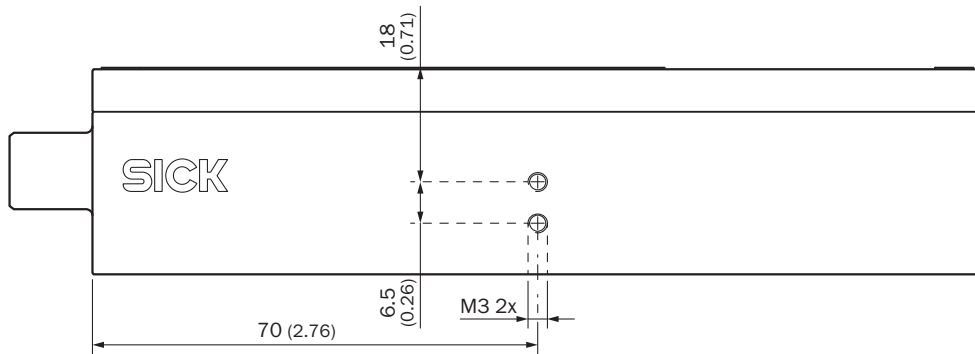

Dimensions in mm (inch)

Dimensional drawing Side view with threaded holes for proximity sensors

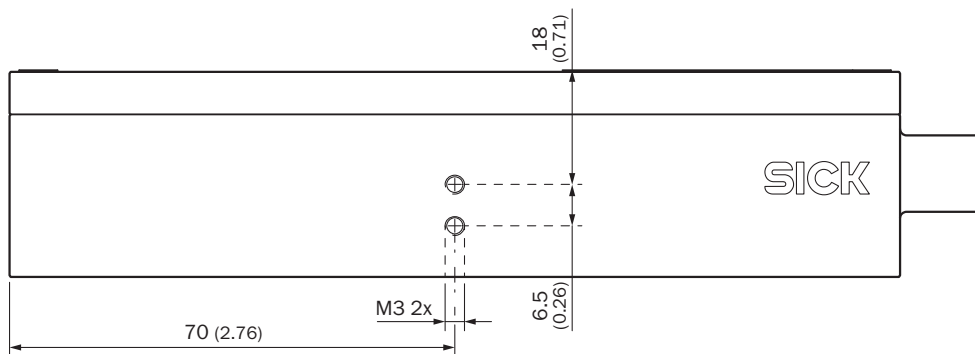

Dimensions in mm (inch)

Dimensional drawing Mounting side

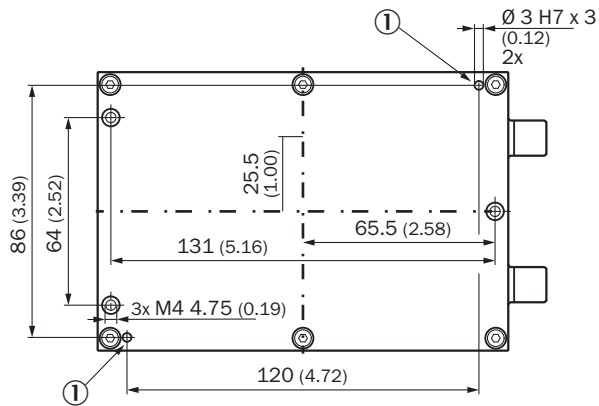

Dimensions in mm (inch)

① Ø 3 H7 x 3 holes for accommodating locating pins

Dimensional drawing SPEETEC 1D

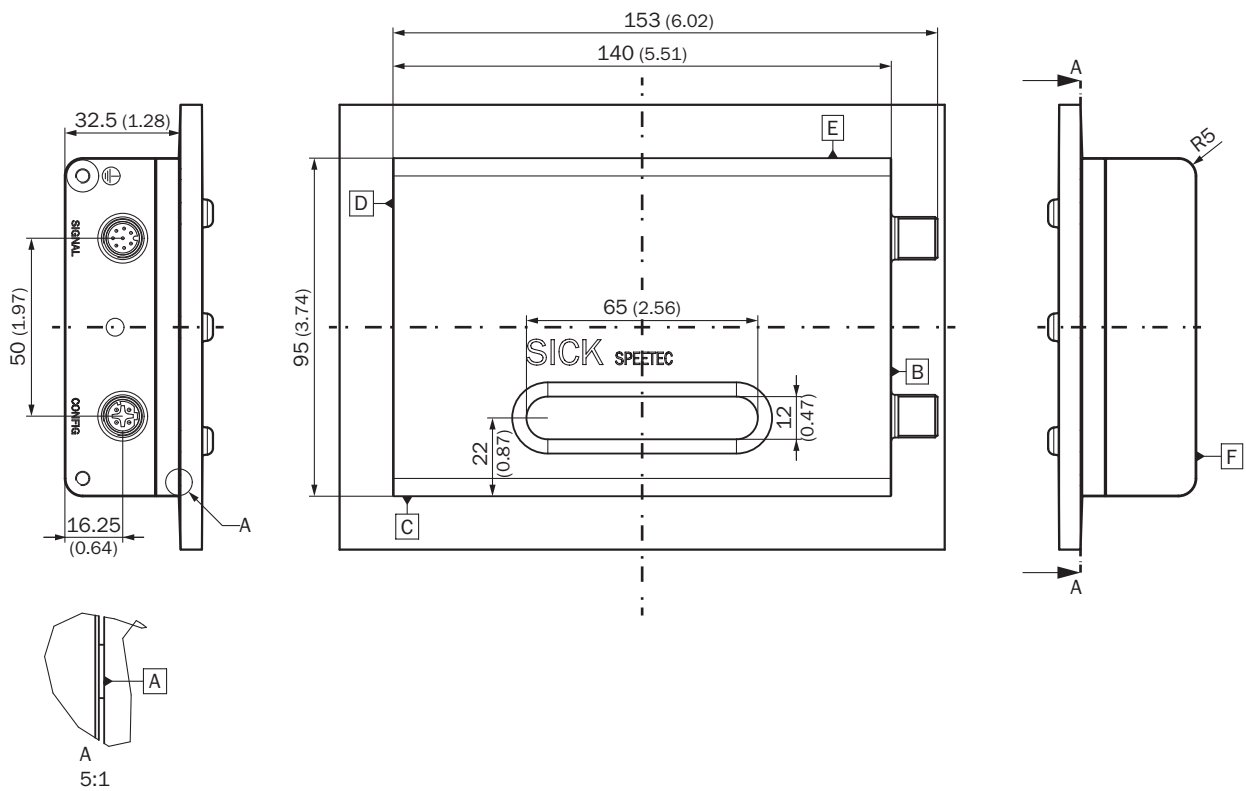

Dimensions in mm (inch)

Attachment specifications Nominal alignment of the sensor to the surface (z-axis)

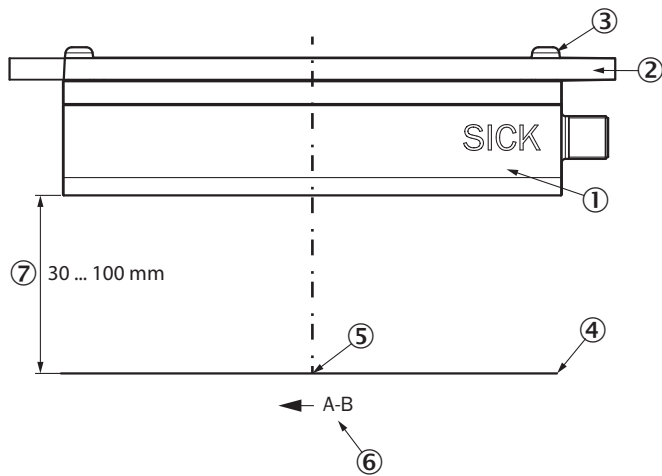

- ① sensor
- ② Mounting surface
- ③ M4 screws
- ④ Surface to be measured
- ⑤ Measuring point on x-/y-plane, 82.5 mm away from the mounting level
- ⑥ Forward material movement; signal sequence A before B
- ⑦ Measuring distance between sensor and surface, also see “Permissible measuring distance” table

Material	Permissible measuring distance
Wood, sawed	30 ... 100 mm
Paper, white	30 ... 100 mm
Conveyor belt, black	50 ... 80 mm
Textile	40 ... 60 mm

Anschlussbelegung

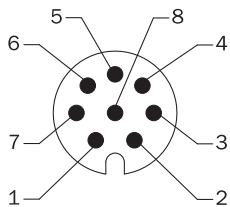

M12 signal male connector, 8-pin and cable, 8-wire

Male connector M12, 8-pin	Wire color	TTL, HTL standard signal	TTL, HTL signal can be programmed	Explanation
1	Brown	A-	A-	Signal cable
2	White	A	A	Signal cable
3	Black	B-	B-	Signal cable
4	Pink	B	B	Signal cable
5	Yellow	Do not wire!	Digital Output	Warning: Observe signal variant!
6	Violet	Do not wire!	Digital input	Warning: Observe signal variant!

Male connector M12, 8-pin	Wire color	TTL, HTL standard signal	TTL, HTL signal can be programmed	Explanation
7	Blue	GND	GND	Ground connection of the sensor
8	Red	+U _S	+U _S	Supply voltage
Shielding	Shielding	Shielding	Shielding	Shielding connected to housing on sensor side, connect to ground on control side
Ground		Earthing point on housing		The sensor must be earthed via the housing at the intended earthing point.
-	-	-	-	-
Technical data of digital input				
Type	Current Sink Type 1/3	-	-	-
Input voltage HIGH	15 V ... 30 V	-	-	-
Input voltage LOW	-3 V ... 5 V	-	-	-
Input current HIGH	2 mA ... 2.6 mA	-	-	-
Input current LOW	0 mA ... 2.6 mA	-	-	-
-	-	-	-	-
Technical data of digital output				
Type	Push-Pull Output	-	-	-
Output voltage HIGH	(U _S - 2 V) ... U _S	-	-	-
Output voltage LOW	0 V ... 2 V	-	-	-
Output current HIGH	0.5 mA ... 30 mA	-	-	-

Diagrams Signal outputs for electrical interfaces TTL and HTL with forward material movement (see assembly specifications)

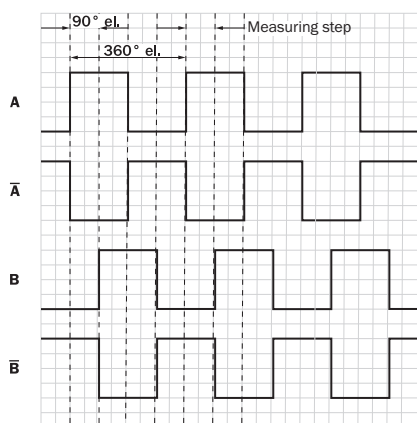





The measuring step corresponds to 90° electrical. The specified resolution, e.g. 4 μm, can only be achieved if the counter card is scanned 4 times. This ensures each signal edge within the 360° el. period (rising A, rising B, falling A, falling B) is counted.

Recommended accessories

Other models and accessories → www.sick.com/SPEETEC_1D

	Brief description	Type	part no.
connectors and cables			
	<ul style="list-style-type: none"> Description: Incremental, shielded, SSI Connection type head A: Female connector, M12, 8-pin, straight Connection type head B: Flying leads Signal type: Incremental, SSI Cable: 2 m, 8-wire, PUR, halogen-free Connection systems: Flying leads Application: Drag chain operation, Zones with oils and lubricants 	DOL-1208-G02MAC1	6032866
	<ul style="list-style-type: none"> Description: Incremental, shielded, SSI Connection type head A: Female connector, M12, 8-pin, straight Connection type head B: Flying leads Signal type: Incremental, SSI Cable: 5 m, 8-wire, PUR, halogen-free Connection systems: Flying leads Application: Drag chain operation, Zones with oils and lubricants 	DOL-1208-G05MAC1	6032867
	<ul style="list-style-type: none"> Description: Incremental, shielded, SSI Connection type head A: Female connector, M12, 8-pin, straight Connection type head B: Flying leads Signal type: Incremental, SSI Cable: 10 m, 8-wire, PUR, halogen-free Connection systems: Flying leads Application: Drag chain operation, Zones with oils and lubricants 	DOL-1208-G10MAC1	6032868
	<ul style="list-style-type: none"> Description: Incremental, shielded, SSI Connection type head A: Female connector, M12, 8-pin, straight Connection type head B: Flying leads Signal type: Incremental, SSI Cable: 20 m, 8-wire, PUR, halogen-free Connection systems: Flying leads Application: Drag chain operation, Zones with oils and lubricants 	DOL-1208-G20MAC1	6032869
	<ul style="list-style-type: none"> Description: Shielded Connection type head A: Female connector, M12, 8-pin, straight Connection type head B: Male connector, M12, 8-pin, straight Cable: 5 m, 8-wire, PUR, halogen-free Application: Zones with oils and lubricants 	DSL-1208-G05MAC1	6032913
	<ul style="list-style-type: none"> Description: SSI, shielded, Incremental Connection type head A: Flying leads Connection type head B: Flying leads Signal type: SSI, Incremental Items supplied: By the meter Cable: 11-wire, PUR 	LTG-2411-MW	6027530
	<ul style="list-style-type: none"> Description: SSI, shielded, Incremental Connection type head A: Flying leads Connection type head B: Flying leads Signal type: SSI, Incremental Items supplied: By the meter Cable: 12-wire, PUR, halogen-free 	LTG-2512-MW	6027531
	<ul style="list-style-type: none"> Description: SSI, shielded, TTL, HTL, Incremental Connection type head A: Flying leads Connection type head B: Flying leads Signal type: SSI, TTL, HTL, Incremental Items supplied: By the meter Cable: 12-wire, UV and saltwater-resistant, PUR, halogen-free 	LTG-2612-MW	6028516
	<ul style="list-style-type: none"> Description: Shielded Connection type head A: Female connector, M12, 8-pin, straight, A-coded Connection systems: Screw-type terminals Permitted cross-section: 0.25 mm² ... 0.5 mm² 	DOS-1208-GA	6028369
	<ul style="list-style-type: none"> Description: Shielded Connection type head A: Male connector, M12, 8-pin, straight, A-coded Connection systems: Screw-type terminals Permitted cross-section: ≤ 0.5 mm² 	STE-1208-GA	6028370
	<ul style="list-style-type: none"> Description: Incremental, shielded, SSI Connection type head A: Female connector, M12, 8-pin, straight Connection type head B: Flying leads 	DOL-1208-G05MAD3	2121359

	Brief description	Type	part no.
	<ul style="list-style-type: none"> Signal type: Incremental, SSI Cable: 5 m, 8-wire, PUR, halogen-free Connection systems: Flying leads 		
	<ul style="list-style-type: none"> Description: HIPERFACE®, shielded, Incremental Connection type head A: Female connector, M12, 8-pin, angled Connection type head B: Flying leads Signal type: HIPERFACE®, Incremental Cable: 20 m, 8-wire, PUR Application: Zones with oils and lubricants 	DOL-1208-W20MAC1	6037727
	<ul style="list-style-type: none"> Description: HIPERFACE®, shielded, Incremental Connection type head A: Female connector, M12, 8-pin, angled Connection type head B: Flying leads Signal type: HIPERFACE®, Incremental Cable: 2 m, 8-wire, PUR, halogen-free Application: Zones with oils and lubricants 	DOL-1208-W02MAC1	6037724
	<ul style="list-style-type: none"> Description: HIPERFACE®, shielded, Incremental Connection type head A: Female connector, M12, 8-pin, angled Connection type head B: Flying leads Signal type: HIPERFACE®, Incremental Cable: 5 m, 8-wire, PUR, halogen-free Application: Zones with oils and lubricants 	DOL-1208-W05MAC1	6037725
	<ul style="list-style-type: none"> Description: HIPERFACE®, shielded, Incremental Connection type head A: Female connector, M12, 8-pin, angled Connection type head B: Flying leads Signal type: HIPERFACE®, Incremental Cable: 10 m, 8-wire, PUR, halogen-free Application: Zones with oils and lubricants 	DOL-1208-W10MAC1	6037726
	<ul style="list-style-type: none"> Description: Ethernet, shielded Connection type head A: Female connector, M12, 8-pin, angled, A-coded Signal type: Ethernet Cable: CAT5, CAT5e Connection systems: QUICKON connection Permitted cross-section: 0.14 mm² ... 0.34 mm² 	DOS-1208-WA	6043358
	<ul style="list-style-type: none"> Description: Shielded Connection type head A: Male connector, M12, 8-pin, A-coded Connection type head B: Female connector, M12, 8-pin, A-coded Connection type head C: Female connector, M8, 4-pin, A-coded Items supplied: Cable A: YM2A28-C20UA6F2A28 (6079346), cable B: YM2A18-C20UA3F8U14 (6079404), Y-distributor: YM2A28-000000FY2A8 (2123351) Cable: 0.2 m, PUR, halogen-free 	YM2A28-C20S01MYAAX	2124388
Commissioning aids and test equipment			
	<ul style="list-style-type: none"> Product: Alignment aids Description: Suitable for NCV50 / SPEETEC. Simplifies mounting of the SPEETEC at the right distance and angle to the surface. Packaging unit: 1 unit 	BEF-WN-NCV50-ADJST	2117003
	<ul style="list-style-type: none"> Product: Alignment aids Description: Laser spot detector map to visualize the SPEETEC NCV50 laser spot for the eye and to determine the correct operating point. 	BEF-SPEETEC-LSD	2120614

	Brief description	Type	part no.
Mounting systems			
	<ul style="list-style-type: none"> • Description: Bracket for mounting SICK photoelectric proximity sensors, W4, W9, G6 to the NCV50. SICK photoelectric proximity sensors from the W4, W9, G6 series can be easily mounted on the NCV50 using the BEF-MK-NCV50-W49G6. This makes it possible to better detect material edges and makes length measurement more exact. The position of the scanning point in the direction of movement is specified by the mounting position, the position in the y-direction can be adjusted using the bracket slots. • Packing unit: 1 piece • Items supplied: Adjustment aid, screws for mounting the photoelectric proximity sensor • Suitable for: NCV50, W4, W9, G6 	BEF-MK-NCV50-W49G6	2117457
	<ul style="list-style-type: none"> • Description: The BEF-WN-NCV50 mounting bracket makes it possible to easily and correctly mount the sensors while complying with the specified tolerances for distance and angle. The BEF-WN-NCV50 mounting bracket can be combined with the BEF-WF-MWS120 mounting bracket. This makes it possible to mount on the machine frame. • Packing unit: 1 piece • Items supplied: Mounting bracket, screws for mounting the NCV50 • Suitable for: NCV50 / SPEETEC 	BEF-WN-NCV50 mounting bracket	2117456
	<ul style="list-style-type: none"> • Description: Mounting bracket for MWS120 measuring wheel system and SPEETEC 1D laser surface motion sensors • Suitable for: MWS120, NCV50 (in conjunction with BEF-WN-NCV50 mounting bracket part no.: 2117456) 	BEF-WF-MWS-NCV	2113284
device protection and care			
	<ul style="list-style-type: none"> • Product family: Cleaning agents • Description: Cloth for cleaning optical surfaces 	Lens cloth	4003353

	Brief description	Type	part no.
Photoelectric sensors			
	<ul style="list-style-type: none"> • Sensing range max.: 25 mm ... 300 mm • Functional principle: Photoelectric proximity sensor • Connection type: Cable with M8 male connector, 4-pin • Type of light: Visible red light • Adjustment: Potentiometer • Housing: Rectangular 	WTB4SL-3P3261	1058238
	<ul style="list-style-type: none"> • Sensing range max.: 5 mm ... 250 mm • Functional principle: Photoelectric proximity sensor • Connection type: Cable with connector M8, 3-pin • Type of light: Visible red light • Adjustment: Potentiometer • Housing: Rectangular 	GTB6-P5211	1059333
	<ul style="list-style-type: none"> • Sensing range max.: 5 mm ... 250 mm • Functional principle: Photoelectric proximity sensor • Connection type: Cable with M8 male connector, 4-pin • Type of light: Visible red light • Adjustment: Potentiometer • Housing: Rectangular 	GTB6-P6211	1059320
	<ul style="list-style-type: none"> • Sensing range max.: 20 mm ... 350 mm • Functional principle: Photoelectric proximity sensor • Functional principle detail: Background suppression • Switching output: PNP • Switching mode: Light/dark switching • Connection type: Cable with M8 male connector, 4-pin, 120 mm • Light source: PinPoint LED • Adjustment: Potentiometer 	WTB9-3P3261	1054306
	<ul style="list-style-type: none"> • Sensing range max.: 25 mm ... 300 mm • Functional principle: Photoelectric proximity sensor • Functional principle detail: Background suppression • Switching output: PNP • Switching mode: Light/dark switching • Connection type: Cable with M8 male connector, 4-pin, 120 mm • Light source: Laser • Adjustment: Potentiometer 	WTB9L-3P3261S03	1073333
integration modules and adapters			
	<ul style="list-style-type: none"> • Description: Table housing suitable for installation of the DIS-IPDTACCR0000 display unit 	DIS-DH30M	7135599
	<ul style="list-style-type: none"> • Description: Digital display with resistive touch screen, for SPEETEC, incremental encoders and measuring wheel encoders. Multi-function device for use as tachometer, speed measuring device, pulse counter, position display, piece counter and total counter Communication interface: incremental Communication interface detailed: RS-422, RS485 	DIS-IPDTACCR0000	4119630

SICK AT A GLANCE

SICK is one of the leading manufacturers of intelligent sensors and sensor solutions for industrial applications. A unique range of products and services creates the perfect basis for controlling processes securely and efficiently, protecting individuals from accidents and preventing damage to the environment.

We have extensive experience in a wide range of industries and understand their processes and requirements. With intelligent sensors, we can deliver exactly what our customers need. In application centers in Europe, Asia and North America, system solutions are tested and optimized in accordance with customer specifications. All this makes us a reliable supplier and development partner.

Comprehensive services complete our offering: SICK LifeTime Services provide support throughout the machine life cycle and ensure safety and productivity.

For us, that is “Sensor Intelligence.”

WORLDWIDE PRESENCE:

Contacts and other locations –www.sick.com