



DATA SHEET

WTB12V-1H161120A00

W12
Photoelectric sensors

PHOTOELECTRIC SENSORS

WT-
B12V-1H161120A00

ORDERING INFORMATION

Type	part no.
WTB12V-1H161120A00	1126065

Further device versions and accessories at www.sick.com/W12



Illustration may differ

DETAILED TECHNICAL DATA

FEATURES

Functional principle	Photoelectric proximity sensor	
Functional principle detail	Background suppression	
Sensing range	Sensing range min.	40 mm
	Sensing range max.	350 mm
Adjustable switching threshold for background suppression	50 mm ... 350 mm	
	Reference object	Object with 90% remission factor (complies with standard white according to DIN 5033)
Minimum distance between set sensing range and background (black 6% / white 90%)	1 mm, at a distance of 80 mm	
Recommended sensing range for the best performance	50 mm ... 100 mm	
Emitted beam	Light source	Laser
	Type of light	Visible red light
	Shape of light spot	Line-shaped
	Light spot size (distance)	1.2 mm x 32 mm (100 mm)
Maximum dispersion of the emitted beam around the standardized transmission axis (squint angle)	< +/- 1.0° (at T ₀ = +23 °C)	
Key laser figures	Normative reference	EN 60825-1:2014, IEC 60825-1:2014
	Laser class	1 ¹⁾
	Wave length	655 nm
	Pulse duration	4 μs
	Maximum pulse power	< 6.74 mW

¹⁾ Do not intentionally look into the laser beam. Never point the laser beam at people's eyes.

Average service life	50,000 h at $T_U = +25\text{ °C}$	
Smallest detectable object (MDO) typ.	32 mm, 1.4 mm, at a distance of 100 mm Object with 90% remission factor (complies with standard white according to DIN 5033)	
Adjustment	Teach-Turn adjustment	BluePilot For setting the sensing range
	IO-Link	For configuring the sensor parameters and Smart Task functions
Display	LED blue	BluePilot: sensing range indicator
	LED green	Operating indicator Static on: power on Flashing: IO-Link mode
	LED yellow	Status of received light beam Static on: object present Static off: object not present
Special features	Line-shaped light spot	
Special applications	Detecting small objects, Detection of objects moving at high speeds, Detecting perforated objects	

¹⁾ Do not intentionally look into the laser beam. Never point the laser beam at people's eyes.

SAFETY-RELATED PARAMETERS

MTTF _D	280 years
DC _{avg}	0 %
T _M (mission time)	10 years

COMMUNICATION INTERFACE

IO-Link		✓, IO-Link V1.1
	Data transmission rate	COM2 (38,4 kBaud)
	Cycle time	2.3 ms
	Process data length	16 Bit
	Process data structure	Bit 0 = switching signal Q ₁
		Bit 1 = switching signal Q ₂
		Bit 2 ... 15 = Current receiver level (live)
	VendorID	26
	DeviceID HEX	0x8002D0
	DeviceID DEC	8389328
	Compatible master port type	A
	SIO mode support	Yes

ELECTRONICS

Supply voltage U _b	10 V DC ... 30 V DC ¹⁾
Ripple	≤ 5 V
Usage category	DC-12 (According to EN 60947-5-2) DC-13 (According to EN 60947-5-2)
Current consumption	≤ 14 mA, without load. At U _b = 24 V

¹⁾ Limit values.

²⁾ Signal transit time with resistive load in switching mode.

³⁾ With light/dark ratio 1:1.

⁴⁾ This switching output must not be connected to another output.

Protection class	III
Digital output	Number 2 (Complementary) Type Push-pull: PNP/NPN Switching mode Light/dark switching Signal voltage PNP HIGH/LOW Approx. $U_B - 2.5 \text{ V} / 0 \text{ V}$ Signal voltage NPN HIGH/LOW Approx. $U_B / < 2.5 \text{ V}$ Output current I_{max} $\leq 100 \text{ mA}$ Circuit protection outputs Reverse polarity protected Overcurrent protected Short-circuit protected Response time $\leq 500 \mu\text{s}$ ²⁾ Repeatability (response time) $150 \mu\text{s}$ ²⁾ Switching frequency $1,000 \text{ Hz}$ ³⁾
Pin/Wire assignment	BN + (L+) WH \bar{Q}_L /MF Digital output, dark switching, object present → output \bar{Q}_L LOW ⁴⁾ The pin 2 function of the sensor can be configured Additional possible settings via IO-Link BU - (M) BK QL1/C Digital output, light switching, object present → output Q_L HIGH ⁴⁾ The pin 4 function of the sensor can be configured IO-Link communication C Additional possible settings via IO-Link

¹⁾ Limit values.

²⁾ Signal transit time with resistive load in switching mode.

³⁾ With light/dark ratio 1:1.

⁴⁾ This switching output must not be connected to another output.

MECHANICS

Housing	Rectangular
Dimensions (W x H x D)	15.6 mm x 49.5 mm x 43.1 mm
Connection	Cable, 4-wire, 2 m
Connection detail	Deep-freeze property Do not bend below 0 °C Conductor size 0.14 mm ² Cable diameter Ø 3.4 mm Length of cable (L) 2 m Bending radius For flexible use > 12 x cable diameter Bending cycles 1,000,000
Material	Housing Metal, zinc diecast Front screen Plastic, PMMA Cable Plastic, PVC
Weight	Approx. 132 g
Maximum tightening torque of the fixing screws	1.4 Nm

AMBIENT DATA

Enclosure rating	IP66 (EN 60529) IP67 (EN 60529) IP69 (EN 60529)
Ambient operating temperature	-20 °C ... +55 °C
Ambient temperature, storage	-40 °C ... +70 °C
Warm-up time	< 15 min, Where T_u is under -10 °C

Typ. Ambient light immunity	Artificial light: ≤ 50,000 lx Sunlight: ≤ 50,000 lx
Shock resistance	50 g, 11 ms (25 positive and 25 negative shocks along X, Y, Z axes, 150 total shocks (EN60068-2-27))
Vibration resistance	10 Hz ... 2,000 Hz (Amplitude 0.5 mm / 10 g, 20 sweeps per axis, for X, Y, Z axes, 1 octave/min, (EN60068-2-6))
Air humidity	35 % ... 95 %, relative humidity (no condensation)
Electromagnetic compatibility (EMC)	EN 60947-5-2
Resistance to cleaning agent	ECOLAB
UL File No.	NRKH.E181493 & NRKH7.E181493

SMART TASK

Smart Task name	Base logics
Logic function	Direct AND OR
Timer function	Deactivated Switch-on delay Off delay ON and OFF delay Impulse (one shot)
Inverter	Yes
Switching frequency	SIO Logic: 900 Hz ¹⁾ IOL: 800 Hz ²⁾
Response time	SIO logic: 550 μs ¹⁾ IOL: 600 μs ²⁾
Repeatability	SIO Logic: 200 μs ¹⁾ IOL: 250 μs ²⁾
Switching signal	Switching signal Q_{Li} Switching output Switching signal \bar{Q}_{Li} Switching output

¹⁾ Use of Smart Task functions without IO-Link communication (SIO mode).

²⁾ Use of Smart Task functions with IO-Link communication function.

DIAGNOSIS

Device temperature	Measuring range	Very cold, cold, moderate, warm, hot
Device status		Yes
Detailed device status		Yes
Operating hour counter		Yes
Operating hours counter with reset function		Yes
Quality of teach		Yes

CERTIFICATES

EU declaration of conformity	✓
UK declaration of conformity	✓
ACMA declaration of conformity	✓
Moroccan declaration of conformity	✓
China RoHS	✓
ECOLAB certificate	✓
cULus certificate	✓

IO-Link certificate	✓
Laser safety (IEC 60825-1) declaration of manufacturer	✓
Information according to Art. 3 of Data Act (Regulation EU 2023/2854)	✓

DIMENSIONAL DRAWING

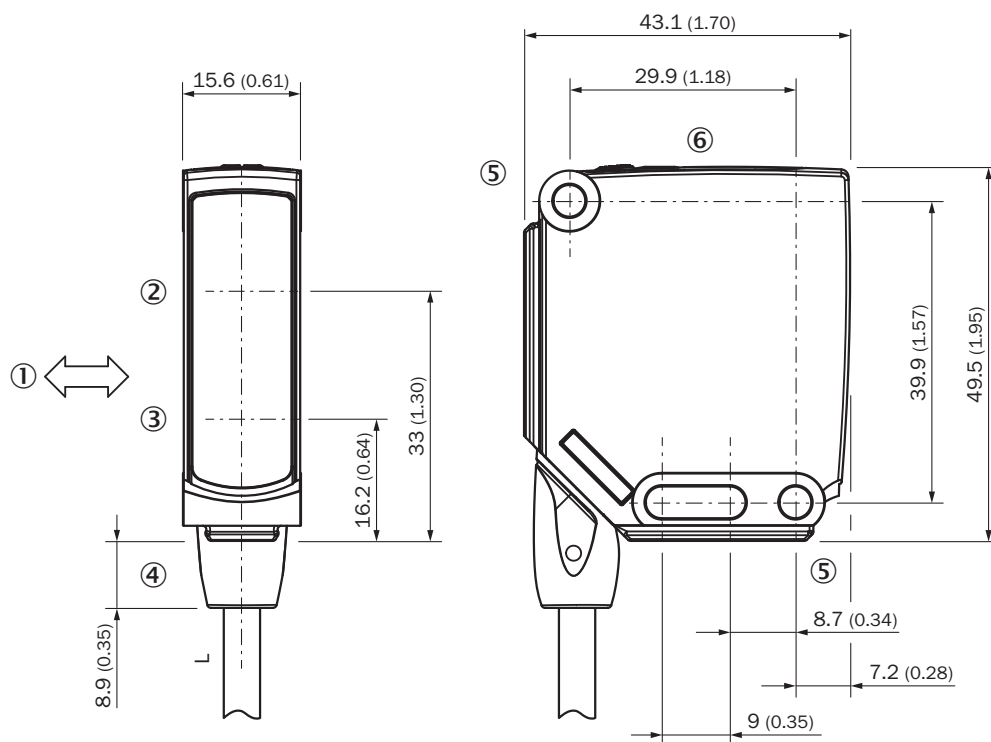

Dimensions in mm (inch)

For length of cable (L), see technical data

- ① Standard direction of the material being detected
- ② Center of optical axis, receiver
- ③ Center of optical axis, sender
- ④ Connection
- ⑤ Mounting hole, Ø 4.2 mm
- ⑥ display and adjustment elements

DISPLAY AND ADJUSTMENT ELEMENTS

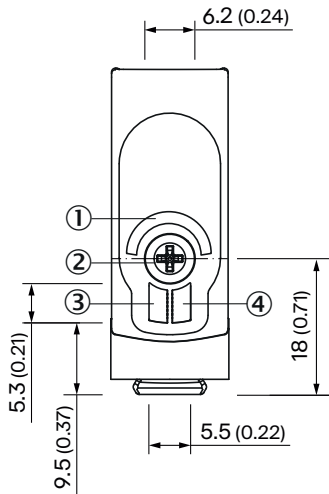

- ① LED blue
- ② Teach-Turn adjustment
- ③ LED green
- ④ LED yellow

CONNECTION TYPE CABLE, 4-WIRE

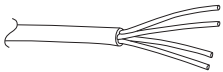

TRUTH TABLE PUSH-PULL: PNP/NPN - LIGHT SWITCHING Q

	Light switching Q (normally open (upper switch), normally closed (lower switch))	
	Object not present → Output LOW	Object present → Output HIGH
Light receive	✗	✔
Light receive indicator	✗	☀
Load resistance to L+	⚡	✗
Load resistance to M	✗	⚡

TRUTH TABLE PUSH-PULL: PNP/NPN - DARK SWITCHING \bar{Q}

	Dark switching \bar{Q} (normally closed (upper switch), normally open (lower switch))	
	Object not present → Output HIGH	Object present → Output LOW
Light receive	⊗	✓
Light receive indicator	⊗	☀
Load resistance to L+	⊗	⚡
Load resistance to M	⚡	⊗

CHARACTERISTIC CURVE

Minimum distance in mm (y) between the set sensing range and white background (90 % remission)

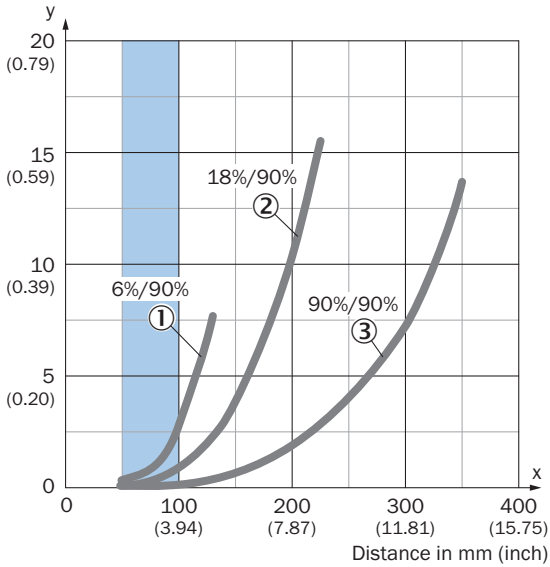

Example:
Safe suppression of the background

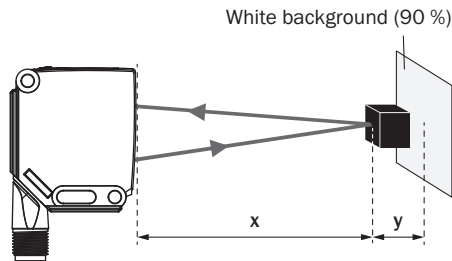

Black object (6 % remission)
Set sensing range $x = 80$ mm
Needed minimum distance to white background $y = 1$ mm

Recommended sensing range for the best performance

- ① Black object, 6% remission factor
- ② Gray object, 18% remission factor
- ③ White object, 90% remission factor

LIGHT SPOT SIZE

Dimensions in mm (inch)

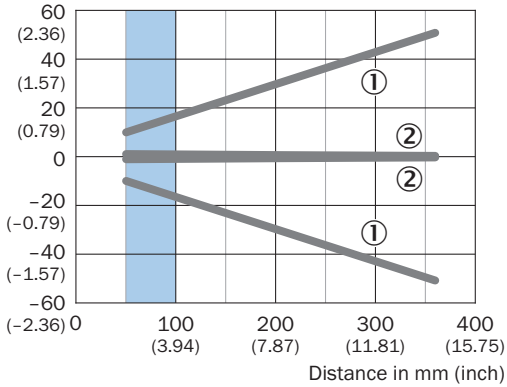

Recommended sensing range for the best performance

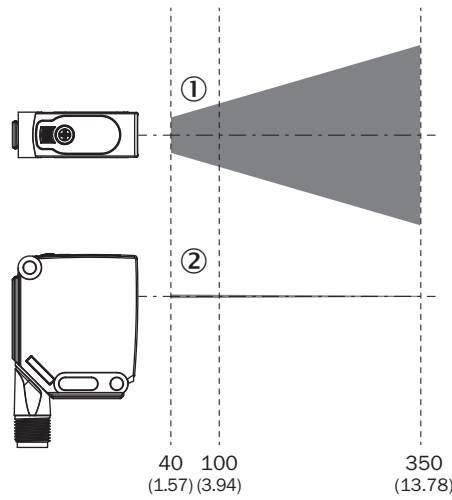

- ① Light spot horizontal
- ② Light spot vertical

SENSING RANGE DIAGRAM

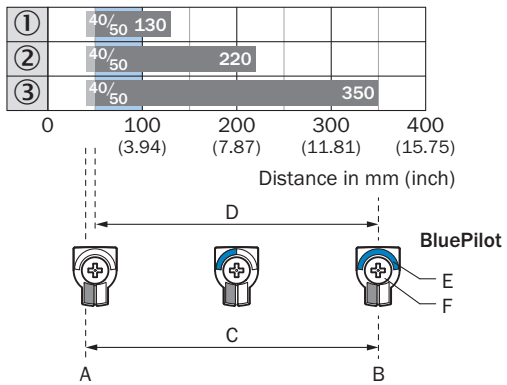

Recommended sensing range for the best performance

1	Black object, 6% remission factor
2	Gray object, 18% remission factor
3	White object, 90% remission factor
A	Sensing range min. in mm
B	Sensing range max. in mm
C	Field of view
D	Adjustable switching threshold for background suppression
E	Sensing range indicator
F	Teach-Turn adjustment

Further information as well as suitable accessories, example applications and downloads such as CAD dimensional models, operating instructions and software can be found at www.sick.com/1126065



SICK AG
WALDKIRCH
GERMANY
SICK.COM

SICK AT A GLANCE

SICK is a leading global technology company for intelligent sensors and integrated solutions in industrial automation. Our technologies set benchmarks, making your industrial processes more efficient, safer and more sustainable – both in logistics and manufacturing operations.

SICK combines sensor intelligence with industry expertise and certified consulting services. We provide the ideal foundation for scalable as well as tailor-made automation solutions and create added value along the entire value chain. Our close partnerships with our customers are more than just a promise: Together, we optimize productivity, improve quality, protect health and safety, and help build a sustainable future. All with empathy and trust.

Since 1946, we have been developing innovative technologies with passion and a pioneering spirit. With a global network in around 40 countries, SICK has a global presence and is always close by. The company's headquarters are located in Waldkirch near Freiburg, Germany. Our customers benefit from our understanding of both local and global requirements, which enables us to deliver tailor-made solutions

SICK
Sensor Intelligence