



DATA SHEET

WTM12L-34161820A00

W12
Photoelectric sensors

SICK

Sensor Intelligence

PHOTOELECTRIC SENSORS

WT-
M12L-34161820A00

ORDERING INFORMATION

Type	part no.
WTM12L-34161820A00	1126054

Further device versions and accessories at www.sick.com/W12



Illustration may differ

DETAILED TECHNICAL DATA

FEATURES

Functional principle	Photoelectric proximity sensor
Functional principle detail	Background suppression, Foreground suppression, MultiMode, distance value
MultiMode	1 Background suppression 2 Foreground suppression 3 Two Value Teach-in 4 Two independent switching points 5 Window Mode 6 ApplicationSelect

¹ 90% remission factor.

² Equivalent to 1 σ .

³ See repeatability characteristic lines.

⁴ Do not intentionally look into the laser beam. Never point the laser beam at people's eyes.

		M manual / measurement	
Sensing range	Sensing range min.	15 mm (mode 1, 3, 4, 5) 0 mm (mode 2) 15 mm (mode 1 and 6 combined)	
	Sensing range max.	420 mm (mode 1, 3, 4, 5) 150 mm (mode 2) 650 mm (mode 1 and 6 combined)	
	Adjustable switching threshold for background suppression	30 mm ... 420 mm (mode 1, 3, 4, 5) 30 mm ... 650 mm (mode 1 and 6 combined)	
	Adjustable switching threshold for foreground suppression	35 mm ... 150 mm (mode 2)	
	Reference object	Object with 90% remission factor (complies with standard white according to DIN 5033)	
	Minimum distance between set sensing range and background (black 6% / white 90%)	4 mm, at a distance of 140 mm (mode 1, 3, 4, 5) 3 mm, at a distance of 200 mm (mode 1 and 6 combined)	
	Minimum object height at set sensing range in front of black background (6% remission factor)	2 mm, at a distance of 90 mm (mode 2)	
	Recommended sensing range for the best performance	40 mm ... 160 mm (mode 1, 3, 4, 5) 40 mm ... 120 mm (mode 2) 40 mm ... 400 mm (mode 1 and 6 combined)	
	Distance value	Measuring range	30 mm ... 420 mm
		Repeatability	0,1 mm ... 4 mm ^{1) 2) 3)}
Accuracy		Typ. 2.0 mm at 30 ... 120 mm distance ¹⁾ Typ. 12 mm at 120 ... 250 mm distance ¹⁾ Typ. 40 mm at 250 ... 400 mm distance ¹⁾	
Distance value output		Via IO-Link	
Resolution		0.1 mm	
Update rate of the distance value		20 ms	
Emitted beam	Light source	Laser	
	Type of light	Visible red light	
	Shape of light spot	Ellipse shape	
	Light spot size (distance)	2.4 mm x 1 mm (160 mm)	
	Maximum dispersion of the emitted beam around the standardized transmission axis (squint angle)	< +/- 1.0° (at T _u = +23 °C)	
Key laser figures	Normative reference	EN 60825-1:2014, IEC 60825-1:2014	
	Laser class	1 ⁴⁾	
	Wave length	655 nm	
	Pulse duration	4 µs	
	Maximum pulse power	< 4.03 mW	
	Average service life	50,000 h at T _u = +25 °C	
Smallest detectable object (MDO) typ.		3 mm, at 160 mm distance, mode 1, 3, 4, 5 2.8 mm, at a distance of 120 mm, mode 2 2.5 mm, at a distance of 200 mm, mode 1 and 6 combined Object with 90% remission factor (complies with standard white according to DIN 5033)	
Adjustment	Teach-Turn adjustment	BluePilot For adjusting the sensing range with mode selection	

¹⁾ 90% remission factor.

²⁾ Equivalent to 1σ.

³⁾ See repeatability characteristic lines.

⁴⁾ Do not intentionally look into the laser beam. Never point the laser beam at people's eyes.

	IO-Link	For configuring the sensor parameters and Smart Task functions
Display	LED blue	BluePilot: Display of mode, display of output states Q_{L1} (LED 3 permanently on) and Q_{L2} (LED 5 permanently on)
	LED green	Operating indicator Static on: power on Flashing: IO-Link mode
	LED yellow	Status of received light beam Static on: object present Static off: object not present
Special features		MultiMode
Special applications		Detecting small objects, Detection of objects moving at high speeds, Detecting flat objects, Detecting uneven, shiny objects, Detection of poorly remitting and tilted objects, Detecting perforated objects

¹ 90% remission factor.

² Equivalent to 1 σ .

³ See repeatability characteristic lines.

⁴ Do not intentionally look into the laser beam. Never point the laser beam at people's eyes.

SAFETY-RELATED PARAMETERS

MTTF _D	280 years
DC _{avg}	0 %
T _M (mission time)	10 years

COMMUNICATION INTERFACE

IO-Link		✓, IO-Link V1.1
	Data transmission rate	COM2 (38,4 kBaud)
	Cycle time	2.3 ms
	Process data length	16 Bit
	Process data structure	Bit 0 = switching signal Q_{L1} Bit 1 = switching signal Q_{L2} Bit 2 ... 15 = Current receiver level (live)
	VendorID	26
	DeviceID HEX	0x8002D2
	DeviceID DEC	8389330
	Compatible master port type	A
	SIO mode support	Yes

ELECTRONICS

Supply voltage U_B	10 V DC ... 30 V DC ¹⁾
Ripple	≤ 5 V
Usage category	DC-12 (According to EN 60947-5-2) DC-13 (According to EN 60947-5-2)
Current consumption	≤ 14 mA, without load. At $U_B = 24 V$

¹⁾ Limit values.

²⁾ Signal transit time with resistive load in switching mode.

³⁾ Mode 1, 2, 3.

⁴⁾ Mode 4, 5.

⁵⁾ Mode 1 and 6 combined.

⁶⁾ With light/dark ratio 1:1.

⁷⁾ This switching output must not be connected to another output.

Protection class	III
Digital output	<p>Number 2 (Complementary)</p> <p>Type Push-pull: PNP/NPN</p> <p>Switching mode Light/dark switching</p> <p>Signal voltage PNP HIGH/LOW Approx. $U_B - 2.5 \text{ V} / 0 \text{ V}$</p> <p>Signal voltage NPN HIGH/LOW Approx. $U_B / < 2.5 \text{ V}$</p> <p>Output current I_{max} $\leq 100 \text{ mA}$</p> <p>Circuit protection outputs Reverse polarity protected Overcurrent protected Short-circuit protected</p> <p>Response time $\leq 200 \mu\text{s}$ ^{2) 3)} $\leq 500 \mu\text{s}$ ^{2) 4)} $\leq 15 \text{ ms}$ ^{2) 5)}</p> <p>Repeatability (response time) $85 \mu\text{s}$ (mode 1, 2, 3) ²⁾ $150 \mu\text{s}$ (mode 4, 5) ²⁾ 5 ms (mode 1 and 6 combined) ²⁾</p> <p>Switching frequency $2,500 \text{ Hz}$ (mode 1, 2, 3) ⁶⁾ $1,000 \text{ Hz}$ (mode 4, 5) ⁶⁾ 30 Hz (mode 1 and 6 combined) ⁶⁾</p>
Pin/Wire assignment	<p>BN 1 + (L+)</p> <p>WH 2 \bar{Q}_L / MF</p> <p>Digital output, dark switching, object present → output \bar{Q}_L1 LOW (Mode 1, 3, 5, 6) ⁷⁾ The pin 2 function of the sensor can be configured</p> <p>Digital output, light switching, object present → output QL1 LOW (Mode 2) ⁷⁾ Additional possible settings via IO-Link</p> <p>Digital output, light switching, object present → output QL2 HIGH (Mode 4) ⁷⁾</p> <p>BU 3 - (M)</p> <p>BK 4 QL1/C</p> <p>Digital output, light switching, object present → output QL1 HIGH (Mode 1, 3, 4, 5, 6) ⁷⁾ The pin 4 function of the sensor can be configured</p> <p>Digital output, dark switching, object present → output \bar{Q}_L1 HIGH (Mode 2) ⁷⁾ Additional possible settings via IO-Link IO-Link communication C</p>

¹⁾ Limit values.

²⁾ Signal transit time with resistive load in switching mode.

³⁾ Mode 1, 2, 3.

⁴⁾ Mode 4, 5.

⁵⁾ Mode 1 and 6 combined.

⁶⁾ With light/dark ratio 1:1.

⁷⁾ This switching output must not be connected to another output.

MECHANICS

Housing	Rectangular
Dimensions (W x H x D)	15.6 mm x 49.5 mm x 43.1 mm
Connection	Cable with M12 male connector, 4-pin, 315 mm
Connection detail	<p>Deep-freeze property Do not bend below 0 °C</p> <p>Conductor size 0.14 mm²</p> <p>Cable diameter $\varnothing 3.4 \text{ mm}$</p> <p>Length of cable (L) 275 mm</p> <p>Bending radius For flexible use > 12 x cable diameter</p>

	Bending cycles	1,000,000
Material	Housing	Metal, zinc diecast
	Front screen	Plastic, PMMA
	Cable	Plastic, PVC
	Male connector	Plastic, VISTAL®
Weight		Approx. 94 g
Maximum tightening torque of the fixing screws		1.4 Nm

AMBIENT DATA

Enclosure rating	IP66 (EN 60529) IP67 (EN 60529) IP69 (EN 60529)
Ambient operating temperature	-20 °C ... +55 °C
Ambient temperature, storage	-40 °C ... +70 °C
Warm-up time	< 15 min, Where T _a is under -10 °C
Typ. Ambient light immunity	Artificial light: ≤ 50,000 lx Sunlight: ≤ 50,000 lx
Shock resistance	50 g, 11 ms (25 positive and 25 negative shocks along X, Y, Z axes, 150 total shocks (EN60068-2-27))
Vibration resistance	10 Hz ... 2,000 Hz (Amplitude 0.5 mm / 10 g, 20 sweeps per axis, for X, Y, Z axes, 1 octave/min, (EN60068-2-6))
Air humidity	35 % ... 95 %, relative humidity (no condensation)
Electromagnetic compatibility (EMC)	EN 60947-5-2
Resistance to cleaning agent	ECOLAB
UL File No.	NRKH.E181493 & NRKH7.E181493

SMART TASK

Smart Task name	Base logics
Logic function	Direct AND OR
Timer function	Deactivated Switch-on delay Off delay ON and OFF delay Impulse (one shot)
Inverter	Yes
Switching frequency	SIO Logic: 2000 Hz (mode 1, 2, 3) ¹⁾ SIO Logic: 900 Hz (mode 4, 5) ¹⁾ SIO Logic: 30 Hz (mode 1 and 6 combined) ¹⁾ IOL: 1600 Hz (mode 1, 2, 3) ²⁾ IOL: 800 Hz (mode 4, 5) ²⁾ IOL: 30 Hz (mode 1 and 6 combined) ²⁾
Response time	SIO Logic: 250 μs (mode 1, 2, 3) ¹⁾ SIO logic: 550 μs (mode 4, 5) ¹⁾ SIO Logic: 15 ms (mode 1 and 6 combined) ¹⁾ IOL: 300 μs (mode 1, 2, 3) ²⁾ IOL: 600 μs (mode 4, 5) ²⁾ IOL: 15 ms (mode 1 and 6 combined) ²⁾
Repeatability	SIO Logic: 120 μs (mode 1, 2, 3) ¹⁾ SIO Logic: 200 μs (mode 4, 5) ¹⁾ SIO Logic: 5 ms (mode 1 and 6 combined) ¹⁾

¹⁾ Use of Smart Task functions without IO-Link communication (SIO mode).

²⁾ Use of Smart Task functions with IO-Link communication function.

		IOL: 150 µs (mode 1, 2, 3) ²⁾ IOL: 250 µs (mode 4, 5) ²⁾ IOL: 5 ms (mode 1 and 6 combined) ²⁾
Switching signal	Switching signal Q_{L1} Switching signal \bar{Q}_{L1}	Switching output Switching output

¹⁾ Use of Smart Task functions without IO-Link communication (SIO mode).

²⁾ Use of Smart Task functions with IO-Link communication function.

DIAGNOSIS

Device temperature	Measuring range	Very cold, cold, moderate, warm, hot
Device status		Yes
Detailed device status		Yes
Operating hour counter		Yes
Operating hours counter with reset function		Yes
Quality of teach		Yes

CERTIFICATES

EU declaration of conformity	✓
UK declaration of conformity	✓
ACMA declaration of conformity	✓
Moroccan declaration of conformity	✓
China RoHS	✓
ECOLAB certificate	✓
cULus certificate	✓
IO-Link certificate	✓
Laser safety (IEC 60825-1) declaration of manufacturer	✓
Information according to Art. 3 of Data Act (Regulation EU 2023/2854)	✓

DIMENSIONAL DRAWING, SENSOR

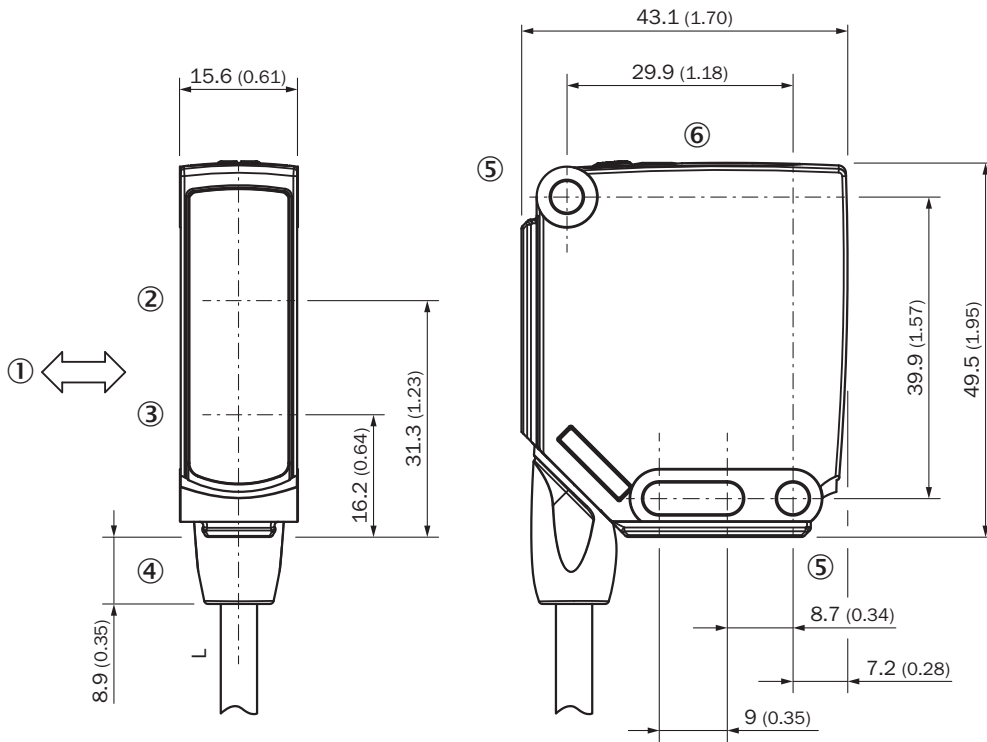

Dimensions in mm (inch)

For length of cable (L), see technical data

- ① Standard direction of the material being detected
- ② Center of optical axis, receiver
- ③ Center of optical axis, sender
- ④ Connection
- ⑤ Mounting hole, \varnothing 4.2 mm
- ⑥ display and adjustment elements

DIMENSIONAL DRAWING, CONNECTION

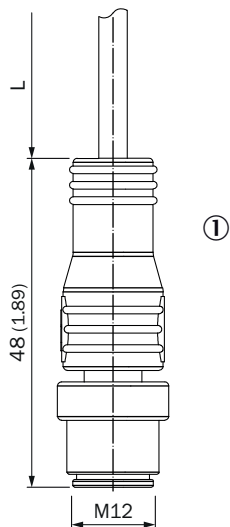

Dimensions in mm (inch)

For length of cable (L), see technical data

- ① Cable with M12 male connector

DISPLAY AND ADJUSTMENT ELEMENTS

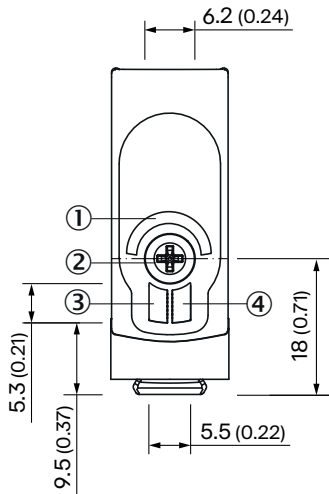

- ① LED blue
- ② Teach-Turn adjustment
- ③ LED green
- ④ LED yellow

DISPLAY AND SETTING DETAIL

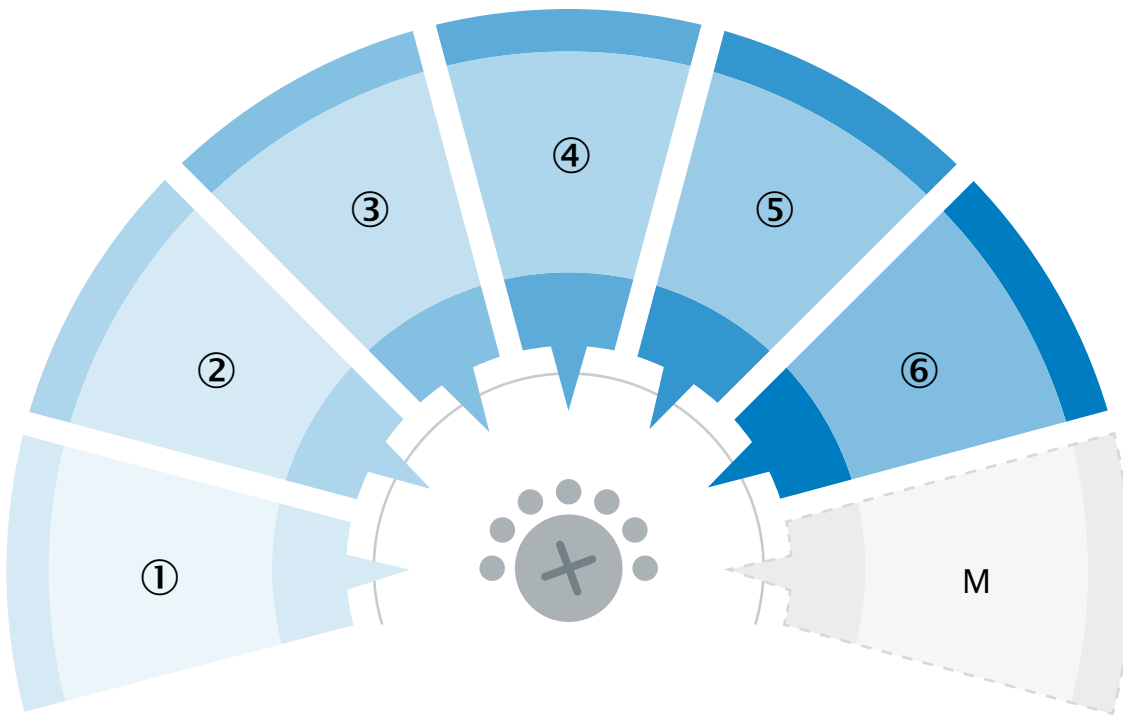

MultiMode settings		
1		Background suppression
2		Foreground suppression
3		Two Value Teach-in
4		Two independent switching points
5		Window Mode
6		ApplicationSelect
M		Manual / measurement

CONNECTION TYPE M12 MALE CONNECTOR, 4-PIN

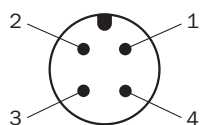

CONNECTION DIAGRAM CD-598 (MODE 1, 2, 3, 5, 6)

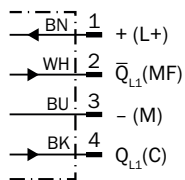

CONNECTION DIAGRAM CD-597 (MODE 4)

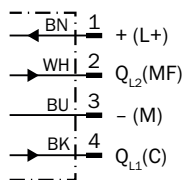

TRUTH TABLE PUSH-PULL: PNP/NPN - DARK SWITCHING \bar{Q}_{L2} (MULTIMODE 4)

	Dark switching \bar{Q}_{L2} (normally closed (upper switch), normally open (lower switch))	
	Object not present → Output HIGH	Object present → Output LOW
Light receive	✗	✓
Light receive indicator	✗	☀
Load resistance to L+	✗	⚡
Load resistance to M	⚡	✗

TRUTH TABLE PUSH-PULL: PNP/NPN - LIGHT SWITCHING Q_{L2} (MULTIMODE 4)

	Light switching Q_{L2} (normally open (upper switch), normally closed (lower switch))	
	Object not present → Output LOW	Object present → Output HIGH
Light receive	✘	✔
Light receive indicator	✘	☀
Load resistance to L+	⚡	✘
Load resistance to M	✘	⚡

TRUTH TABLE PUSH-PULL: PNP/NPN - DARK SWITCHING \bar{Q}_{L1} (MULTIMODE 4)

	Dark switching \bar{Q}_{L1} (normally closed (upper switch), normally open (lower switch))	
	Object not present → Output HIGH	Object present → Output LOW
Light receive	✘	✔
Light receive indicator	✘	☀
Load resistance to L+	✘	⚡
Load resistance to M	⚡	✘

TRUTH TABLE PUSH-PULL: PNP/NPN - LIGHT SWITCHING Q_{L1} (MULTIMODE 4)

	Light switching Q_{L1} (normally open (upper switch), normally closed (lower switch))	
	Object not present → Output LOW	Object present → Output HIGH
Light receive	⊗	✔
Light receive indicator	⊗	☀
Load resistance to L+	⚡	⊗
Load resistance to M	⊗	⚡

TRUTH TABLE PUSH-PULL: PNP/NPN - DARK SWITCHING \bar{Q} (MULTIMODE 2)

	Dark switching \bar{Q} (normally closed (upper switch), normally open (lower switch))	
	Object not present → Output HIGH	Object present → Output LOW
Light receive	⊗	✔
Light receive indicator	⊗	☀
Load resistance to L+	⊗	⚡
Load resistance to M	⚡	⊗

TRUTH TABLE PUSH-PULL: PNP/NPN - LIGHT SWITCHING Q (MULTIMODE 2)

	Light switching Q (normally open (upper switch), normally closed (lower switch))	
	Object not present → Output LOW	Object present → Output HIGH
Light receive	✘	✔
Light receive indicator	✘	☀
Load resistance to L+	⚡	✘
Load resistance to M	✘	⚡

TRUTH TABLE PUSH-PULL: PNP/NPN - LIGHT SWITCHING Q (MULTIMODE 1, 3, 5, 6)

	Light switching Q (normally open (upper switch), normally closed (lower switch))	
	Object not present → Output LOW	Object present → Output HIGH
Light receive	✘	✔
Light receive indicator	✘	☀
Load resistance to L+	⚡	✘
Load resistance to M	✘	⚡

TRUTH TABLE PUSH-PULL: PNP/NPN - DARK SWITCHING \bar{Q} (MULTIMODE 1, 3, 5, 6)

	Dark switching \bar{Q} (normally closed (upper switch), normally open (lower switch))	
	Object not present → Output HIGH	Object present → Output LOW
Light receive	⊗	✓
Light receive indicator	⊗	☀
Load resistance to L+	⊗	⚡
Load resistance to M	⚡	⊗

CHARACTERISTIC CURVE MODE 1, 3, 4, 5

Minimum distance in mm (y) between the set sensing range and white background (90 % remission)

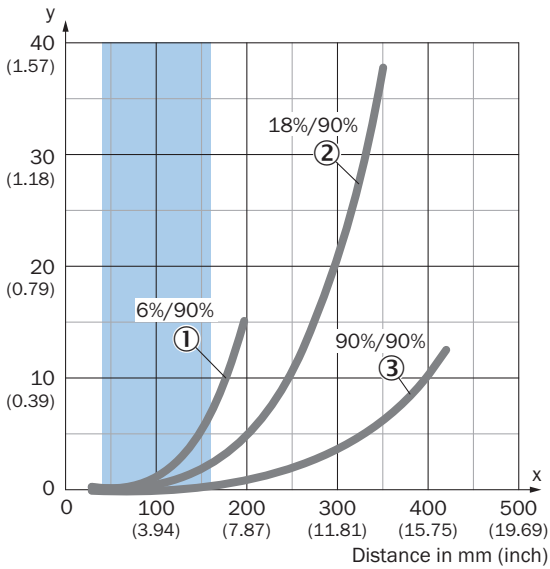

Example:
Safe suppression of the background

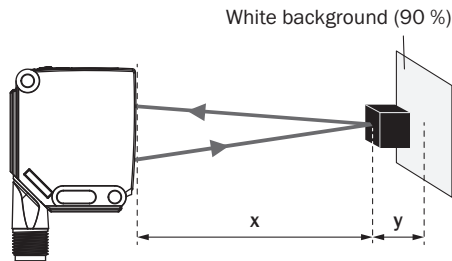

Black object (6 % remission)
Set sensing range $x = 140$ mm
Needed minimum distance to white background $y = 4$ mm

Recommended sensing range for the best performance

- ① Black object, 6% remission factor
- ② Gray object, 18% remission factor
- ③ White object, 90% remission factor

CHARACTERISTIC CURVE MODE 2

Minimum object height in mm (inch)

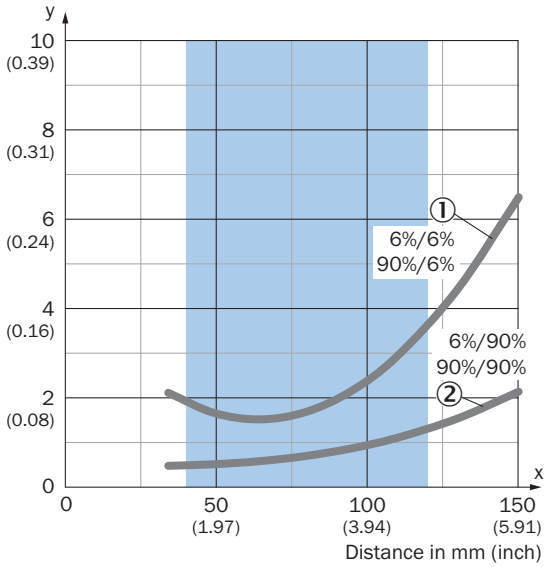

Recommended sensing range for the best performance

- ① Black background, 6% remission factor
- ② White background, 90% remission factor

Example:
Reliable detection of the object

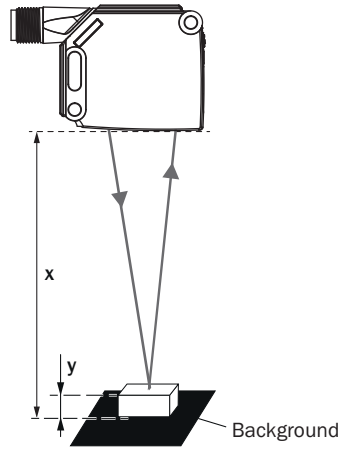

Black background (6 % remission factor)
Distance of sensor to background $x = 90$ mm
Required minimum object height $y = 2$ mm
For all objects regardless of their colors

CHARACTERISTIC CURVE MODE 1 AND 6 COMBINED

Minimum distance in mm (y) between the set sensing range and white background (90 % remission)

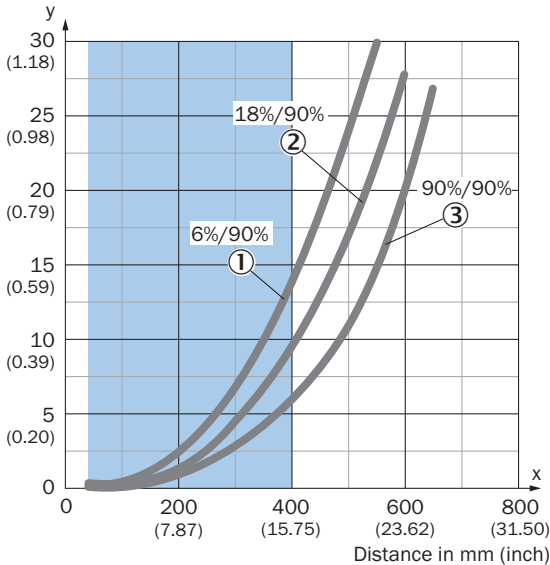

Recommended sensing range for the best performance

- ① Black object, 6% remission factor
- ② Gray object, 18% remission factor
- ③ White object, 90% remission factor

Example:
Safe suppression of the background

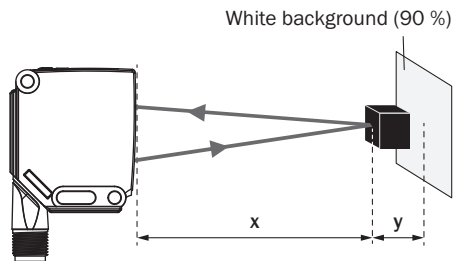

Black object (6 % remission)
Set sensing range $x = 200$ mm
Needed minimum distance to white background $y = 4$ mm

LIGHT SPOT SIZE MODE 1, 3, 4, 5

Dimensions in mm (inch)

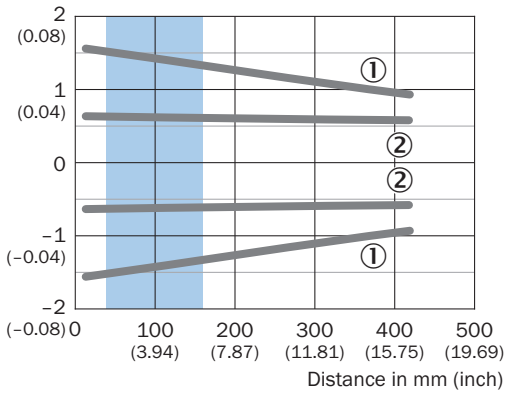

Recommended sensing range for the best performance

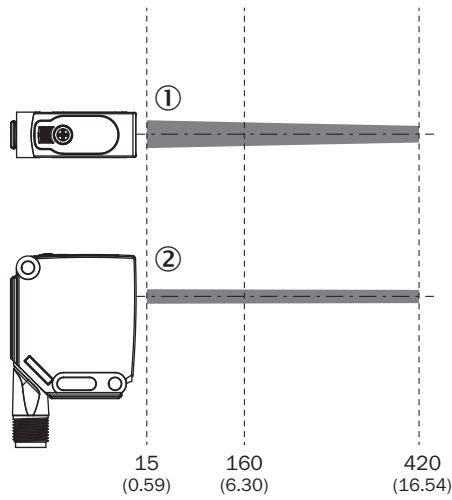

- ① Light spot horizontal
- ② Light spot vertical

LIGHT SPOT SIZE MODE 2

Dimensions in mm (inch)

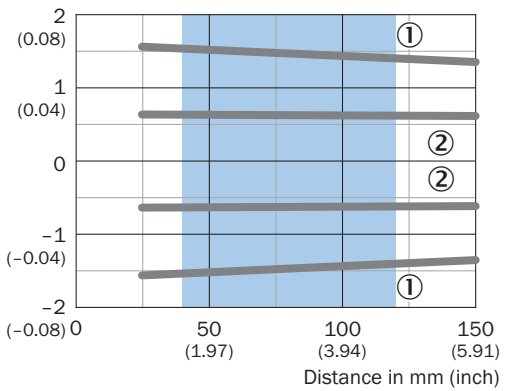

Recommended sensing range for the best performance

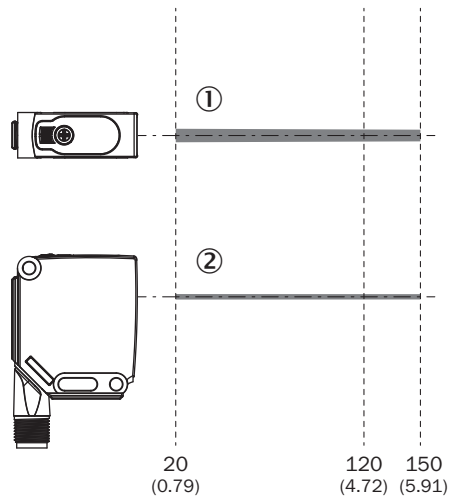

- ① Light spot horizontal
- ② Light spot vertical

LIGHT SPOT SIZE MODE 1 AND 6 COMBINED

Dimensions in mm (inch)

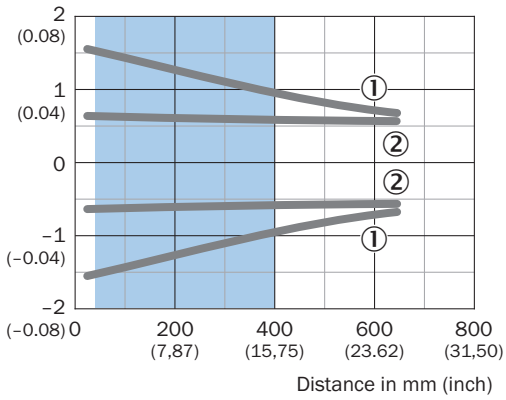

Recommended sensing range for the best performance

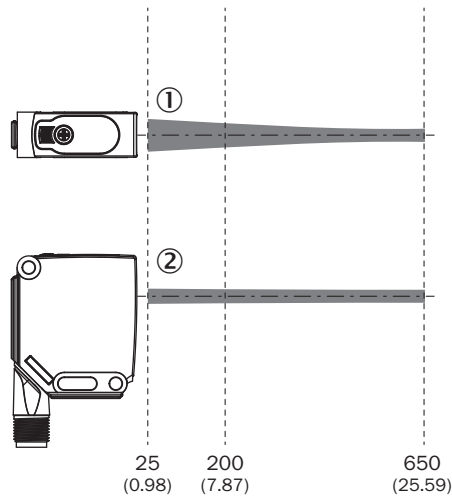

- ① Light spot horizontal
- ② Light spot vertical

SENSING RANGE DIAGRAM MODE 2

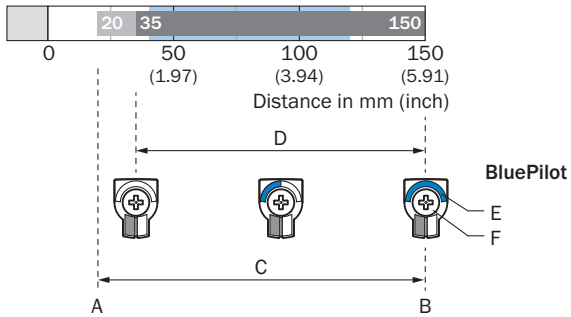

Recommended sensing range for the best performance

A	Sensing range min. in mm
B	Sensing range max. in mm
C	Field of view
D	Adjustable switching threshold for foreground suppression
E	Sensing range indicator
F	Teach-Turn adjustment

SENSING RANGE DIAGRAM MODE 1, 3, 4, 5

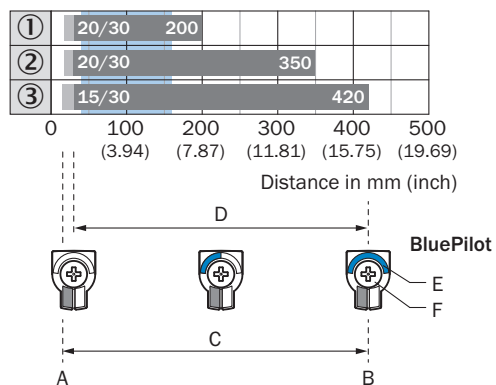

Recommended sensing range for the best performance

1	Black object, 6% remission factor
2	Gray object, 18% remission factor
3	White object, 90% remission factor
A	Sensing range min. in mm
B	Sensing range max. in mm
C	Field of view
D	Adjustable switching threshold for background suppression
E	Sensing range indicator
F	Teach-Turn adjustment

SENSING RANGE DIAGRAM MODE 1 AND 6 COMBINED

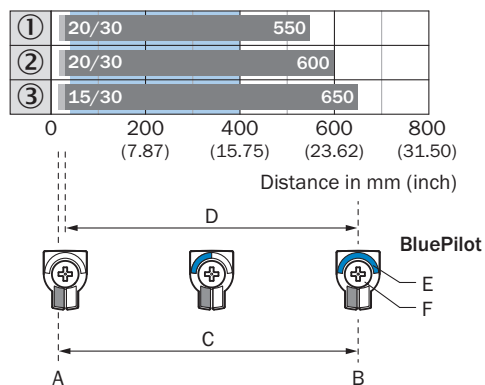

Recommended sensing range for the best performance

1	Black object, 6% remission factor
2	Gray object, 18% remission factor
3	White object, 90% remission factor
A	Sensing range min. in mm
B	Sensing range max. in mm
C	Field of view
D	Adjustable switching threshold for background suppression
E	Sensing range indicator
F	Teach-Turn adjustment

Further information as well as suitable accessories, example applications and downloads such as CAD dimensional models, operating instructions and software can be found at www.sick.com/1126054



SICK AG
WALDKIRCH
GERMANY
SICK.COM

SICK AT A GLANCE

SICK is a leading global technology company for intelligent sensors and integrated solutions in industrial automation. Our technologies set benchmarks, making your industrial processes more efficient, safer and more sustainable – both in logistics and manufacturing operations.

SICK combines sensor intelligence with industry expertise and certified consulting services. We provide the ideal foundation for scalable as well as tailor-made automation solutions and create added value along the entire value chain. Our close partnerships with our customers are more than just a promise: Together, we optimize productivity, improve quality, protect health and safety, and help build a sustainable future. All with empathy and trust.

Since 1946, we have been developing innovative technologies with passion and a pioneering spirit. With a global network in around 40 countries, SICK has a global presence and is always close by. The company's headquarters are located in Waldkirch near Freiburg, Germany. Our customers benefit from our understanding of both local and global requirements, which enables us to deliver tailor-made solutions

SICK
Sensor Intelligence