



# PLB-5150100

PLB

ROBOT GUIDANCE SYSTEMS

**SICK**  
Sensor Intelligence.



## Ordering information

| Type        | part no. |
|-------------|----------|
| PLB-5150100 | 1114995  |

Other models and accessories → [www.sick.com/PLB](http://www.sick.com/PLB)



## Detailed technical data

### Features

|   |  |
|---|--|
| <b>Product version</b>                    | PLB-515  |
| <b>Field of view</b>                      | Large  |
| <b>Classification</b>                     | Pro  |
| <b>Tasks</b>                              | Position determination                                       |
| <b>Applications</b>                       | Robot guidance   |
| <b>Camera type</b>                        | 3D snapshot  |
| <b>Example volume of view (L x W x H)</b> | 600 mm x 500 mm x 500 mm                                     |
| <b>Image resolution</b>                   | 0.38 mm ... 1.36 mm, depending on the distance to the camera |
| <b>Light source</b>                       | LED, blue, 465 nm  |
| <b>LED class</b>                          | Risk group 0 (Exempt, IEC62471 : 2006)                       |
| <b>3D CAD format</b>                      | IGES, STEP   |
| <b>Localization principle</b>             | CAD-model, geometrical shape and edge localization           |
| <b>Technology</b>                         | 3D snapshot, image analysis                                  |

### Mechanics/electronics

|                               |                               |
|-------------------------------|-------------------------------|
| <b>Connection type</b>        | M9 male connector, 7-pin      |
| <b>Supply voltage</b>         | 12 V ... 24 V, Or PoE Class 3 |
| <b>Current consumption</b>    | 2 A                           |
| <b>Dimensions (L x W x H)</b> | 192 mm x 50 mm x 52 mm        |
| <b>Weight</b>                 | 650 g                         |
| <b>Enclosure rating</b>       | IP65 / IP67                   |

### Performance

|                               |                                   |
|-------------------------------|-----------------------------------|
| <b>Part localization time</b> | 3 s ... 10 s, typical             |
| <b>Part size</b>              | (approx.) > 50 mm x 50 mm x 50 mm |
| <b>Part characteristics</b>   | Simple and complex part shapes    |

### Interfaces

|                        |  |
|------------------------|--|
| <b>Ethernet</b>        |  |
| Data transmission rate | 1 Gbit/s (camera), 10/100 Mbit/s (robot) |
| Protocol               | TCP/IP (camera)                          |

|                       |      |
|-----------------------|------|
| Electrical connection | RJ45 |
|-----------------------|------|

### Ambient data

|                                       |  |
|---------------------------------------|--|
| <b>Ambient temperature, operation</b> | 0 °C ... +40 °C, Non-condensing        |
| <b>Shock load</b>                     | 80 g/1,9 ms, 25 g / 6 ms <sup>1)</sup> |
| <b>Vibration load</b>                 | 30-500 Hz / 10 g <sup>2)</sup>         |

<sup>1)</sup> IEC 60068-2-27.

<sup>2)</sup> IEC 60068-2-6.

### General notes

|                           |  |
|---------------------------|--|
| <b>Items supplied</b>     | N36 camera<br>PLB Application Software |
| <b>Factory calibrated</b> | ✓                                      |

### Certificates

|  |   |
|--|---|
| <b>ACMA declaration of conformity</b>  | ✓ |
| <b>China RoHS</b>  | ✓ |
| <b>Information according to Art. 3 of Data Act (Regulation EU 2023/2854)</b> | ✓ |

### Classifications

|                     |          |
|---------------------|----------|
| <b>ECLASS 5.0</b>   | 27381501 |
| <b>ECLASS 5.1.4</b> | 27381501 |
| <b>ECLASS 6.0</b>   | 27381590 |
| <b>ECLASS 6.2</b>   | 27381590 |
| <b>ECLASS 7.0</b>   | 27381590 |
| <b>ECLASS 8.0</b>   | 27381590 |
| <b>ECLASS 8.1</b>   | 27381590 |
| <b>ECLASS 9.0</b>   | 27381590 |
| <b>ECLASS 10.0</b>  | 27381590 |
| <b>ECLASS 11.0</b>  | 27381591 |
| <b>ECLASS 12.0</b>  | 27381591 |

Dimensional drawing

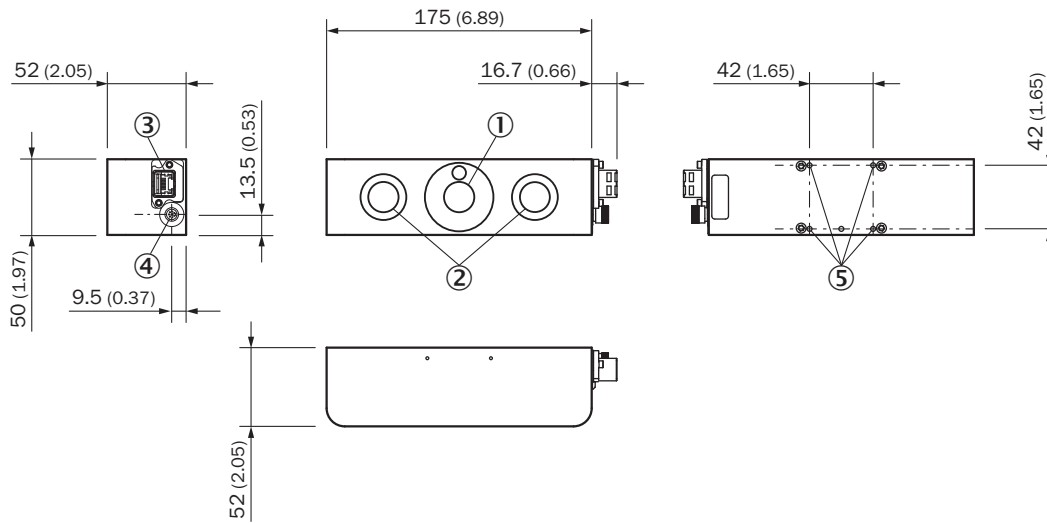

Dimensions in mm (inch)

- ① LED projection module
- ② Image sensor
- ③ Ethernet (RJ45)
- ④ Power / I/O (Binder 712, 7-pin)
- ⑤ Fastening threads (4x M4 x 0.7 mm, 8 mm deep)

Recommended accessories

Other models and accessories → [www.sick.com/PLB](http://www.sick.com/PLB)

|   | Brief description  | Type              | part no. |
|---|--|-------------------|----------|
| Power supply units and power supply cables  |  |                   |          |
|  | <ul style="list-style-type: none"> <li>• <b>Input voltage:</b> ≤ 230 V AC</li> <li>• <b>Output voltage:</b> 24 V DC</li> <li>• <b>Output current:</b> 10 A</li> <li>• <b>Description:</b> Power supply unit</li> </ul> | Power supply unit | 6032863  |

## SICK AT A GLANCE

SICK is one of the leading manufacturers of intelligent sensors and sensor solutions for industrial applications. A unique range of products and services creates the perfect basis for controlling processes securely and efficiently, protecting individuals from accidents and preventing damage to the environment.

We have extensive experience in a wide range of industries and understand their processes and requirements. With intelligent sensors, we can deliver exactly what our customers need. In application centers in Europe, Asia and North America, system solutions are tested and optimized in accordance with customer specifications. All this makes us a reliable supplier and development partner.

Comprehensive services complete our offering: SICK LifeTime Services provide support throughout the machine life cycle and ensure safety and productivity.

For us, that is “Sensor Intelligence.”

## WORLDWIDE PRESENCE:

Contacts and other locations –[www.sick.com](http://www.sick.com)