

SICK

DBV50E-2ZAZZ0S04

DBV50

MEASURING WHEEL ENCODERS

SICK
Sensor Intelligence.



Ordering information

Type	part no.
DBV50E-2AZZ0S04	1109917

Illustration may differ

Other models and accessories → www.sick.com/DBV50



Detailed technical data

Features

Special device	✓
Specialty	Rotatable spring arm, with M6 thread for mounting in the application Customized measuring wheel with vulcanised Vulkollan L93D measuring surface plan with encoder shaft mounted Cable, 8-wire, 2.3 m with JST connector, type PAP-08V-S
Standard reference device	DBV50E-2AZZ0S01, 1076638

Safety-related parameters

MTTF_D (mean time to dangerous failure)	600 years (EN ISO 13849-1) ¹⁾
--	--

¹⁾ This product is a standard product and does not constitute a safety component as defined in the Machinery Directive. Calculation based on nominal load of components, average ambient temperature 40 °C, frequency of use 8760 h/a. All electronic failures are considered hazardous. For more information, see document no. 8015532.

Performance

Pulses per revolution	1,024
Measuring increment (resolution in mm/pulse)	0.195
Measuring step deviation	± 18°, / pulses per revolution
Error limits	± 2 mm ¹⁾ ²⁾ -30 °C: +2 mm/m ... -3 mm/m ³⁾ +25 °C ... +60 °C: -1 mm/m ... -4 mm/m, values apply at relative humidity: ≤ 35% +25 °C ... +60 °C: -1 mm/m ... -4.5 mm/m, values apply at relative humidity: ≥ 35%
Duty cycle	≤ 0.5 ± 5 %
Initialization time	< 3 ms

¹⁾ The specified error limits are dynamic under load and based on a statistical value related to $1\text{ m} \pm 2\sigma$. The values were determined in a representative series of measurements as described in footnote 2. If there is increased relative humidity > 35%, the error limit for the specified temperature ranges increases.

²⁾ Dynamic error limits were determined under the following ambient conditions: Speed: 5 m/s = 1,500 rpm; acceleration of measuring wheel: 2 m/s²; distance traveled: CW/CCW 100 m, surface quality of measuring surface: overturned aluminum reference roller with Ø98.7 mm, DBV50 contact pressure: 15 N, reference encoder AFM60-TGPM262144.

³⁾ The surface of a measuring wheel is subject to wear. This depends on contact pressure, acceleration behavior in the application, traversing speed, measurement surface, mechanical alignment of the measuring wheel, temperature, and ambient conditions. We recommend you regularly check the condition of the measuring wheel and replace as required.

Interfaces

Communication interface	Incremental
Communication Interface detail	TTL / RS-422

Number of signal channels	6-channel
----------------------------------	-----------

Electronics

Connection type	Special version
Connection type Detail	Cable, 8-wire, 2.3 m with JST connector, type PAP-08V-S
Supply voltage	4.5 V ... 5.5 V
Load current max.	30 mA
Maximum output frequency	≤ 300 kHz
Reference signal, number	1
Reference signal, position	90°, electric, logically gated with A and B
Reverse polarity protection	-
Short-circuit protection of the outputs	✓ ¹⁾

¹⁾ The short-circuit rating is only given if Us and GND are connected correctly.

Mechanics

Measuring wheel circumference	200 mm with vulcanized Asmaprene L93D measuring surface ± 0.5 mm at 25 °C
Measuring wheel surface	Vulcanised Vulkollan L93D
Spring arm design	63.5 mm spring arm, encoder on mounting side (left), single wheel
Mass	+ 375 g
Encoder material	
Shaft	Stainless steel
Flange	Aluminum
Housing	Aluminum
Cable	PVC
Spring arm mechanism material	
Spring element	Spring steel
Measuring wheel core	Aluminum
Start up torque	0.9 Ncm (at 20 °C)
Operating torque	0.6 Ncm (at 20 °C)
Operating speed	3,000 min ⁻¹ ¹⁾
Maximum operating speed	1,500 min ⁻¹
Bearing lifetime	2 x 10 ⁹ revolutions
Maximum travel/deflection of spring arm	14 mm at 14 N spring travel ²⁾
Recommended pretension	15 N At 10 mm deflection ³⁾
Max. permissible working area for the spring (continuous operation)	± 3 mm
Mounting position relative to the measuring object	Preferably from above, from below possible ⁴⁾
Mechanical design	Solid shaft, face mount flange
Moment of inertia of the rotor	0.65 gcm ²

¹⁾ No permanent operation. Decreasing signal quality.

²⁾ Note: Exceeding the maximum deflection can lead to plastic deformation of the spring and hence to a change in the spring force.

³⁾ When measured from the top of the measuring surface.

⁴⁾ When mounted from below, the encoder weight during spring pretensioning must be taken into account.

Ambient data

EMC	According to EN 61000-6-2 and EN 61000-6-3 (class A)
Enclosure rating housing with cable connection	IP65
Protection class standard	IEC 60529
Enclosure rating	IP65
Permissible relative humidity	90 % (Condensation not permitted)
Operating temperature range	-30 °C ... +60 °C
Storage temperature range	-40 °C ... +70 °C, without package
Resistance to shocks	100 g, 6 ms (EN 60068-2-27)
Resistance to vibration	20 g, 10 Hz ... 2,000 Hz (EN 60068-2-6)

Classifications

ECLASS 5.0	27270501
ECLASS 5.1.4	27270501
ECLASS 6.0	27270590
ECLASS 6.2	27270590
ECLASS 7.0	27270501
ECLASS 8.0	27270501
ECLASS 8.1	27270501
ECLASS 9.0	27270501
ECLASS 10.0	27270790
ECLASS 11.0	27270707
ECLASS 12.0	27270504
ETIM 5.0	EC001486
ETIM 6.0	EC001486
ETIM 7.0	EC001486
ETIM 8.0	EC001486
UNSPSC 16.0901	41112113

Certificates

EU declaration of conformity	✓
UK declaration of conformity	✓
ACMA declaration of conformity	✓
China RoHS	✓
cRUus certificate	✓
Information according to Art. 3 of Data Act (Regulation EU 2023/2854)	✓

Dimensional drawing

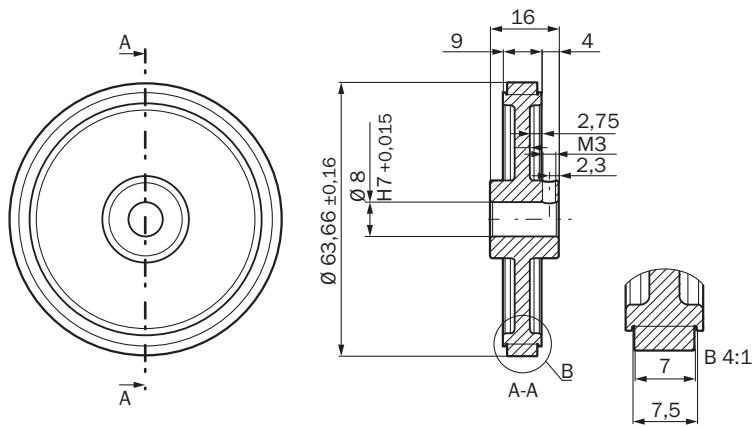

Dimensions in mm (inch)

Dimensional drawing

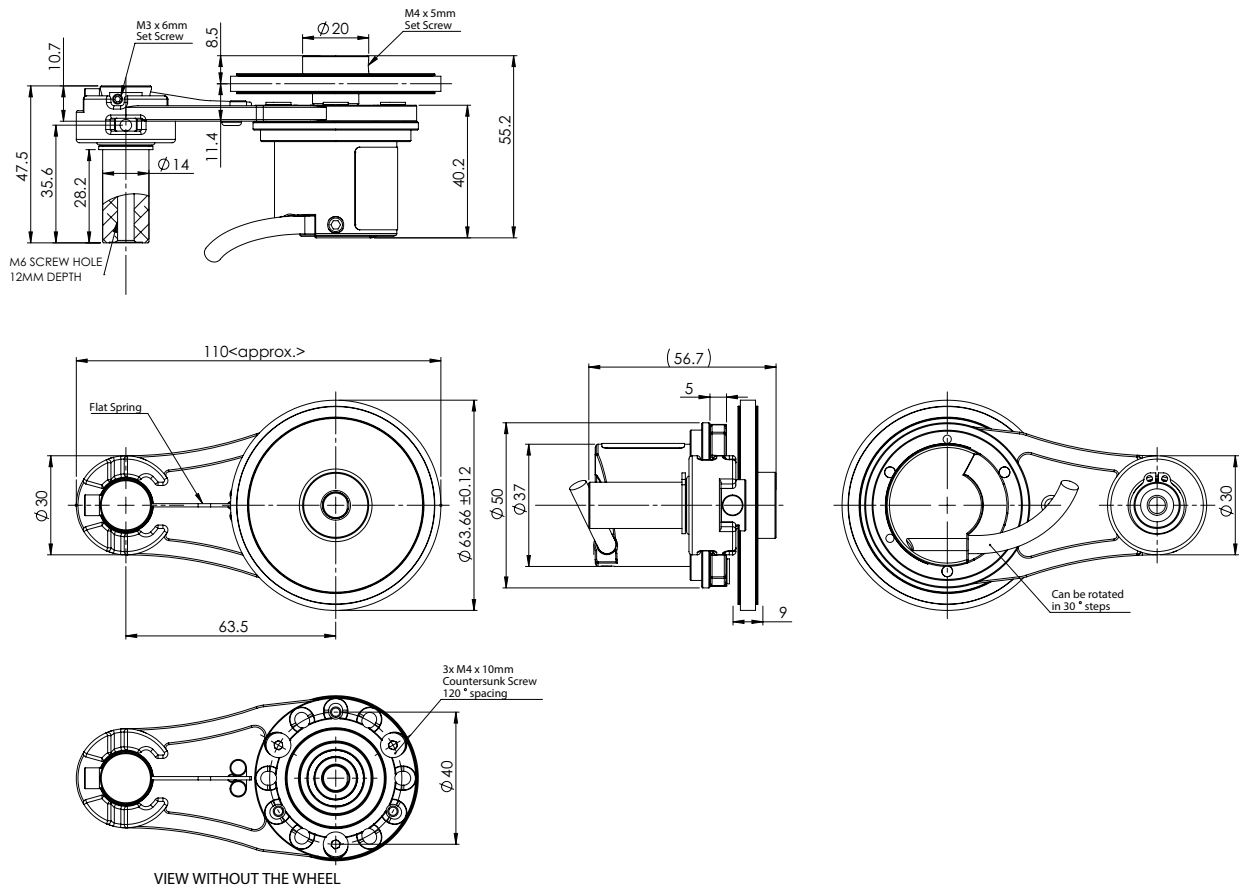

Dimensions in mm (inch)

Dimensional drawing

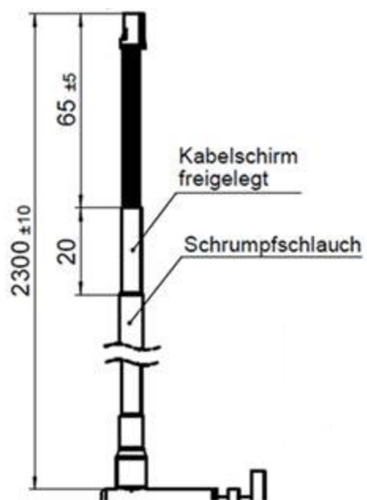

Dimensions in mm (inch)

Dimensional drawing

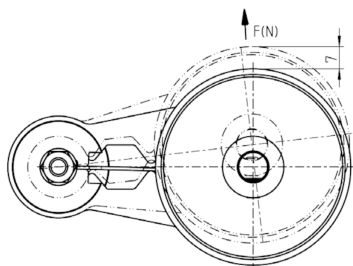

Dimensions in mm (inch)

Diagrams Signal outputs for electrical interfaces TTL and HTL



CW with view on the encoder shaft , compare dimensional drawing.
Interfaces G, P, R perform only the channels A, B, Z.

Diagrams

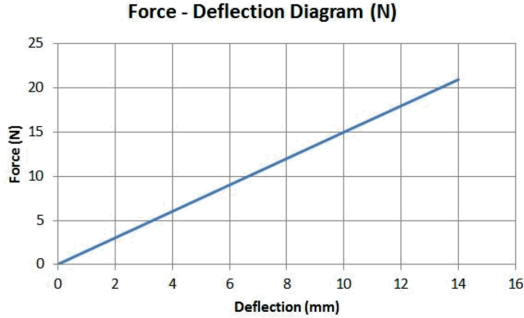

SICK AT A GLANCE

SICK is one of the leading manufacturers of intelligent sensors and sensor solutions for industrial applications. A unique range of products and services creates the perfect basis for controlling processes securely and efficiently, protecting individuals from accidents and preventing damage to the environment.

We have extensive experience in a wide range of industries and understand their processes and requirements. With intelligent sensors, we can deliver exactly what our customers need. In application centers in Europe, Asia and North America, system solutions are tested and optimized in accordance with customer specifications. All this makes us a reliable supplier and development partner.

Comprehensive services complete our offering: SICK LifeTime Services provide support throughout the machine life cycle and ensure safety and productivity.

For us, that is “Sensor Intelligence.”

WORLDWIDE PRESENCE:

Contacts and other locations –www.sick.com