



LMS4111R-13000

LMS4000

2D LIDAR SENSORS

SICK
Sensor Intelligence.



Ordering information

Type	part no.
LMS4111R-13000	1091423

Other models and accessories → www.sick.com/LMS4000



Detailed technical data

Features

Application	Indoor
Reading field	Front
Light source	Visible red light (660 nm)
Laser class	2 (IEC 60825-1:2014, EN 60825-1:2014)
Aperture angle	
	Horizontal 70°
Scanning frequency	600 Hz
Angular resolution	
	Horizontal 0.0833°
Working range	0.7 m ... 3 m
Scanning range	
	At 2% remission factor 2.3 m
	At 3.5% remission factor 3 m
	At 10% remission factor 3 m

Mechanics/electronics

Connection type	1 x M12, 5-pin plug (Power + I/O + Sync) 1 x M12, 8-pin female connector (Ethernet) 1 x M12, 5-pin female connector (Encoder + I/O)
Supply voltage	24 V DC, ± 25 %
Power consumption	≤ 16 W, start-up phase max. 29 W
Output current	≤ 100 mA
Housing material	Aluminum die cast
Housing color	Light blue (RAL 5012)
Enclosure rating	IP65
Protection class	III
Electrical safety	IEC 61010-1:2011
Weight	2.4 kg
Dimensions (L x W x H)	192 mm x 130 mm x 107 mm
MTBF	80 years

MTTFd	> 100 years
--------------	-------------

Safety-related parameters

MTTF_D	> 100 years
-------------------------	-------------

Performance

Scan/frame rate	504,600 measurement point/s
Response time	≥ 4.8 ms
Detectable object shape	Almost any
Systematic error	± 1.5 mm ¹⁾
Statistical error	2.5 mm ¹⁾
Integrated application	Output of measurement data
Filter	Rectangular filter Edge filter Median filter Gloss compensation Average filter

¹⁾ Typical value; actual value depends on environmental conditions.

Interfaces

Ethernet	✓ , TCP/IP, UDP/IP
Function	Measurement data output (distance, RSSI, angle)
Data transmission rate	100 Mbit/s ... 1,000 Mbit/s, half/full-duplex
Digital inputs/outputs	
Inputs	2
Outputs	3
Encoder inputs	2 (phase A, phase B)
Synchronization inputs/outputs	One (master / slave)
Optical indicators	4 LEDs
Configuration software	SOPAS ET
Maximum encoder frequency	Max. 50 kHz

Ambient data

Remission factor	3.5 % ... 300 %
Electromagnetic compatibility (EMC)	EN 61000-6-3:2007+A1:2011 / IEC 61000-6-3:2006+AMD1:2010
Vibration resistance	EN 60068-2-6:2007
Shock resistance	EN 60068-2-27:2008
Ambient operating temperature	-10 °C ... +50 °C ¹⁾
Storage temperature	-20 °C ... +70 °C
Permissible relative humidity	≤ 90 %, Non-condensing
Ambient light immunity	2,000 lx

¹⁾ Initialization phase: 0 °C ... 50 °C.

General notes

Note on use	The sensor does not constitute a safety component as defined by relevant legislation on machine safety.
--------------------	---

Certificates

EU declaration of conformity	✓
UK declaration of conformity	✓
ACMA declaration of conformity	✓
China RoHS	✓
cTUVus certificate	✓

Classifications

ECLASS 5.0	27270990
ECLASS 5.1.4	27270990
ECLASS 6.0	27270913
ECLASS 6.2	27270913
ECLASS 7.0	27270913
ECLASS 8.0	27270913
ECLASS 8.1	27270913
ECLASS 9.0	27270913
ECLASS 10.0	27270913
ECLASS 11.0	27270913
ECLASS 12.0	27270913
ETIM 5.0	EC002550
ETIM 6.0	EC002550
ETIM 7.0	EC002550
ETIM 8.0	EC002550
UNSPSC 16.0901	41111615

Dimensional drawing

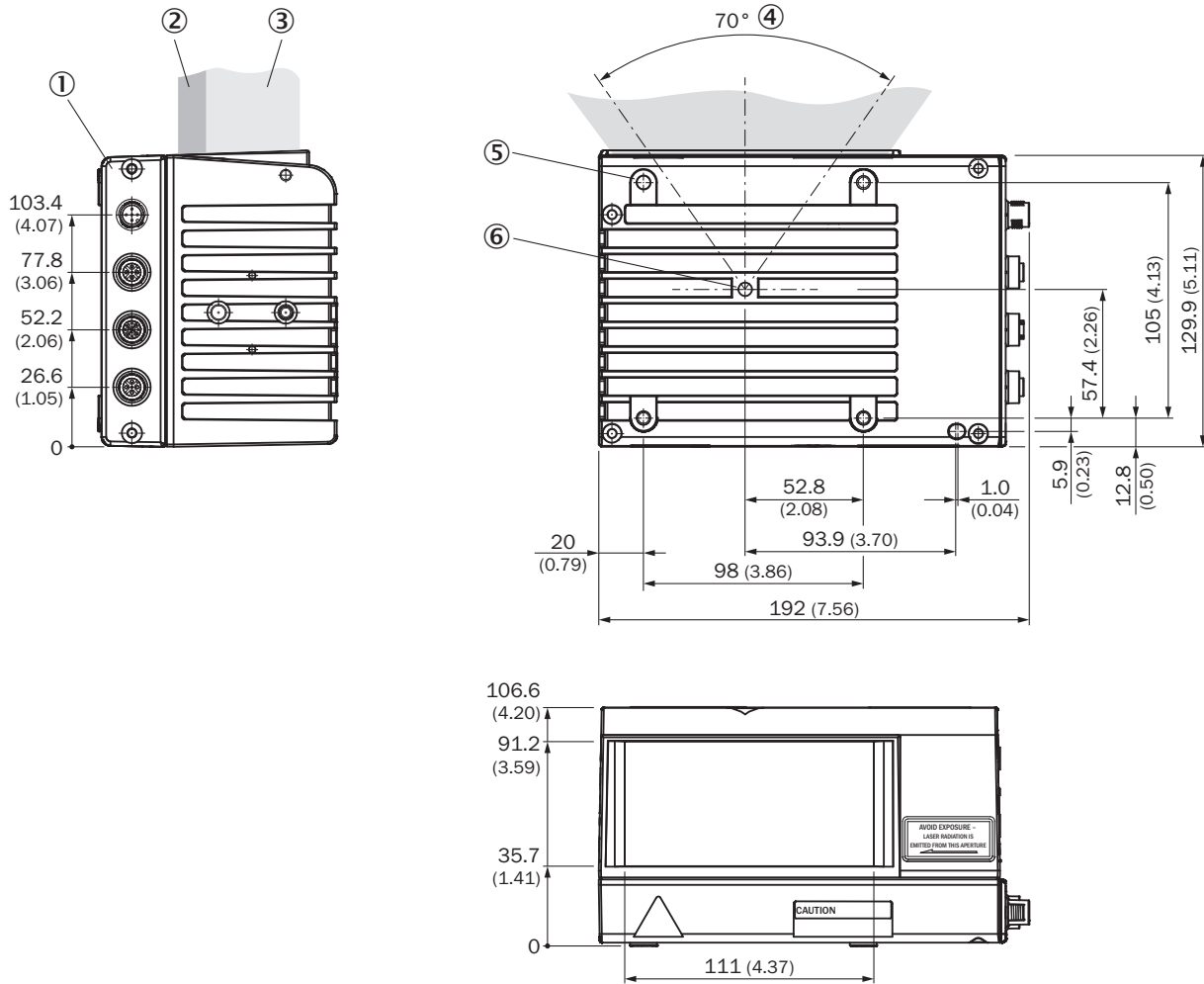

Dimensions in mm (inch)

- ① interfaces, types and number can vary
- ② Sending area
- ③ receiving area
- ④ aperture angle
- ⑤ reference boreholes
- ⑥ Distance measurement zero point

Working range diagram

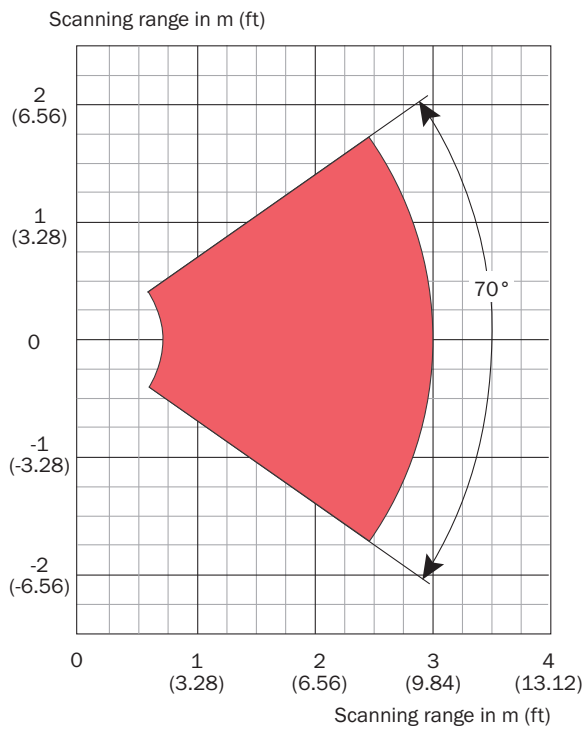

■ Working range 0.7 m to 3 m

gigabit Ethernet

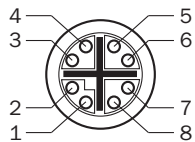

M12, 8-pin socket, X-coded (Gigabit Ethernet)

- ① TRD0_P
- ② TRD0_N
- ③ TRD1_P
- ④ TRD1_N
- ⑤ TRD3_P
- ⑥ TRD3_N
- ⑦ TRD2_P
- ⑧ TRD2_N

PIN assignment Encoders

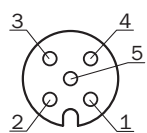

Female connector M12, 5-pin, A-coded

- ① 24 V DC \pm 25 %

- ② Encoders B
- ③ GND
- ④ Encoders A
- ⑤ IN1/OUT1

PIN assignment Power

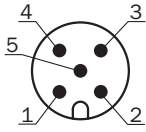









Connector M12, 5-pin, A-coded

- ① 24 V DC ± 25 %
- ② SYNC
- ③ GND
- ④ IN2/OUT2
- ⑤ OUT4

Recommended accessories

Other models and accessories → www.sick.com/LMS4000

	Brief description	Type	part no.
connectors and cables			
	<ul style="list-style-type: none"> • Description: Sensor/actuator cable, shielded • Connection type head A: Female connector, M12, 5-pin, straight, A-coded • Connection type head B: Male connector, M12, 5-pin, straight, A-coded • Signal type: Sensor/actuator cable • Cable: 5 m, 5-wire, PUR, halogen-free • Application: Uncontaminated zones, Zones with oils and lubricants, Robot, Drag chain operation 	YF2A85-050UB6M2A85	2096119
	<ul style="list-style-type: none"> • Description: Sensor/actuator cable, shielded • Connection type head A: Female connector, M12, 5-pin, straight, A-coded • Connection type head B: Flying leads • Signal type: Sensor/actuator cable • Cable: 5 m, 5-wire, PUR, halogen-free • Application: Drag chain operation, Zones with oils and lubricants, Robot, Drag chain operation 	YF2A25-050UB6XLEAX	2095733
	<ul style="list-style-type: none"> • Description: Sensor/actuator cable, shielded • Connection type head A: Female connector, M12, 5-pin, straight, A-coded • Connection type head B: Flying leads • Signal type: Sensor/actuator cable • Cable: 2 m, 5-wire, PUR, halogen-free • Application: Drag chain operation, Zones with oils and lubricants, Robot, Drag chain operation 	YF2A25-020UB6XLEAX	2145583
	<ul style="list-style-type: none"> • Description: Sensor/actuator cable, shielded • Connection type head A: Female connector, M12, 5-pin, straight, A-coded • Connection type head B: Flying leads • Signal type: Sensor/actuator cable • Cable: 1 m, 5-wire, PUR, halogen-free • Application: Drag chain operation, Zones with oils and lubricants, Robot, Drag chain operation 	YF2A25-010UB6XLEAX	2145582
	<ul style="list-style-type: none"> • Connection type head A: Male connector, M12, 8-pin, straight, X-coded • Connection type head B: Male connector, RJ45, 8-pin, straight • Signal type: Ethernet, Gigabit Ethernet • Cable: 5 m, 8-wire, PUR, halogen-free • Description: Ethernet, shielded, Gigabit Ethernet • Application: Zones with oils and lubricants 	YM2X18-050EG1M-RJA8	2106259

	Brief description	Type	part no.
Power supply units and power supply cables			
	<ul style="list-style-type: none"> • Input voltage: 100 V AC ... 240 V AC • Output voltage: 24 V DC • Output current: 2.1 A • Enclosure rating: IP20 	PS50W-24V	7028789
Mounting systems			
	<ul style="list-style-type: none"> • Description: Holder for Item Profile 	Alignment bracket	2030421
Measuring wheel encoders			
	<ul style="list-style-type: none"> • Measuring wheel circumference: 300 mm • Measuring wheel surface: O-ring NBR70 • Communication interface: 10 V ... 32 V, Incremental, HTL, Push pull • Supply voltage: 10 V ... 32 V • Pulses per revolution: 1,500 • Connection type: Special version • Resolution in pulses/mm: 5 • Specialty: M12 male connector, 5-pin 	DFV60B-22EZ0-S03	1051292

SICK AT A GLANCE

SICK is one of the leading manufacturers of intelligent sensors and sensor solutions for industrial applications. A unique range of products and services creates the perfect basis for controlling processes securely and efficiently, protecting individuals from accidents and preventing damage to the environment.

We have extensive experience in a wide range of industries and understand their processes and requirements. With intelligent sensors, we can deliver exactly what our customers need. In application centers in Europe, Asia and North America, system solutions are tested and optimized in accordance with customer specifications. All this makes us a reliable supplier and development partner.

Comprehensive services complete our offering: SICK LifeTime Services provide support throughout the machine life cycle and ensure safety and productivity.

For us, that is “Sensor Intelligence.”

WORLDWIDE PRESENCE:

Contacts and other locations –www.sick.com