



PLOC2D-654C

PLOC2D

ROBOT GUIDANCE SYSTEMS

SICK
Sensor Intelligence.



Ordering information

Type	part no.
PLOC2D-654C	1087255

Other models and accessories → www.sick.com/PLOC2D



Detailed technical data

Features

Product name	PLOC2D-FLEX0001
System features	Stand-alone sensor with easy teach, for localization of parts using 2D measurements
Light source	
	Illumination LEDs: (to be ordered separately as accessories)
Laser class	1, complies with 21 CFR 1040.10 except for the conformance according to "Laser Notice No. 50" from June 24, 2007 (IEC 60825-1:2014) EN 60825-1:2014
Optical focus	Adjustable focus (manually)
Localization principle	Shape comparison
Sensor resolution	2,048 px x 2,048 px (4.2 MP)
Lens	C-mount
Mounting method	Changeable
Optical format	1"
Remark	To be ordered separately as accessories
Technology	2D snapshot, image analysis
Description	High resolution 2D localization of parts in large fields of view

Mechanics/electronics

Connection type	1 x M12, 17-pin male connector (serial, I/Os, voltage supply) 1 x M8, 4-pin female connector (USB, not used) 2 x M12, 8-pin socket (Gigabit Ethernet, only one connection used)
Supply voltage	24 V, ± 20 %
Power consumption	10 W, ± 20 %
Housing material	Aluminum die cast
Housing color	Light blue (RAL 5012)
Dimensions (L x W x H)	142.8 mm x 90 mm x 106.1 mm (Housing only, without lens and optics protection hood)
Weight	635 g
Enclosure rating	IP65 ¹⁾

¹⁾ When using optics cover and male connector.

Performance

Part localization time	< 0.5 seconds for the first part in the image and then < 100 ms for additional parts in the image
-------------------------------	---

Localization accuracy	± 0.5 px, ± 0.1°
Output data	X, Y (mm), rotation around Z (degrees)

Interfaces

Ethernet	✓
Data transmission rate	100 Mbit/s
Protocol	TCP/IP XML and CSV (robot), TCP/IP (operator) PROFINET EtherNet/IP™ FTP
Electrical connection	M12 male connector, 8-pin, x-coded
Supply voltage	
Electrical connection	M12, 4-pin, A-coded
User interface	Web server
Data storage and retrieval	Image and data logging via microSD memory card and external FTP

Ambient data

Ambient temperature, operation	0 °C ... +50 °C, permissible relative humidity: 0% ... 90% (non-condensing)
Ambient temperature, storage	-20 °C ... +70 °C ¹⁾
Shock load	EN 60068-2-27:2009-05
Vibration load	EN 60068-2-6:2008-02

¹⁾ Permissible relative humidity: 0% ... 90% (non-condensing).

General notes

Items supplied	Camera with C-mount PLOC2D software Not included with delivery: Optics and illumination
-----------------------	---

Certificates

EU declaration of conformity	✓
UK declaration of conformity	✓
ACMA declaration of conformity	✓
China RoHS	✓
Information according to Art. 3 of Data Act (Regulation EU 2023/2854)	✓

Classifications

ECLASS 5.0	27381501
ECLASS 5.1.4	27381501
ECLASS 6.0	27381590
ECLASS 6.2	27381590
ECLASS 7.0	27381590
ECLASS 8.0	27381590
ECLASS 8.1	27381590
ECLASS 9.0	27381590
ECLASS 10.0	27381590
ECLASS 11.0	27381591

Dimensional drawing

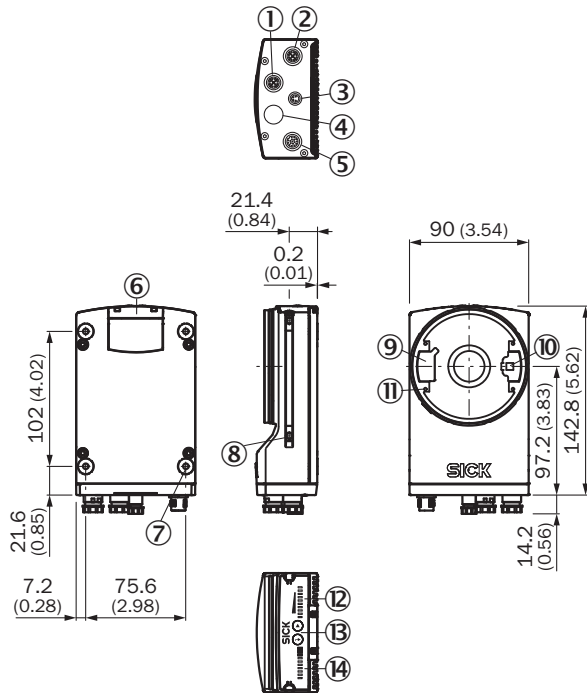

Dimensions in mm (inch)

- ① "Ethernet" P1 connection
- ② P3 connection "Ethernet"
- ③ X2 "USB" connection or "trigger external lighting", depending on type
- ④ P2 connection "CAN OUT", depending on type
- ⑤ X1 "Power/Serial Data/CAN/I/O" connection or "CAN IN", depending on type
- ⑥ cover for the microSD memory card
- ⑦ M5 blind tapped holes, 5 mm deep (4 x), for mounting the sensor
- ⑧ sliding nut M5, 5.5 mm deep (2 x), for mounting (as alternative)
- ⑨ plug connector for connecting the integrated lighting
- ⑩ laser alignment aid exit
- ⑪ 2.5 mm blind tapped holes (4 x) for mounting the spacers for the integrable illumination
- ⑫ Bar graph display
- ⑬ Function button (2 x)
- ⑭ LED for status display (2 levels), 10 x

Characteristic curve

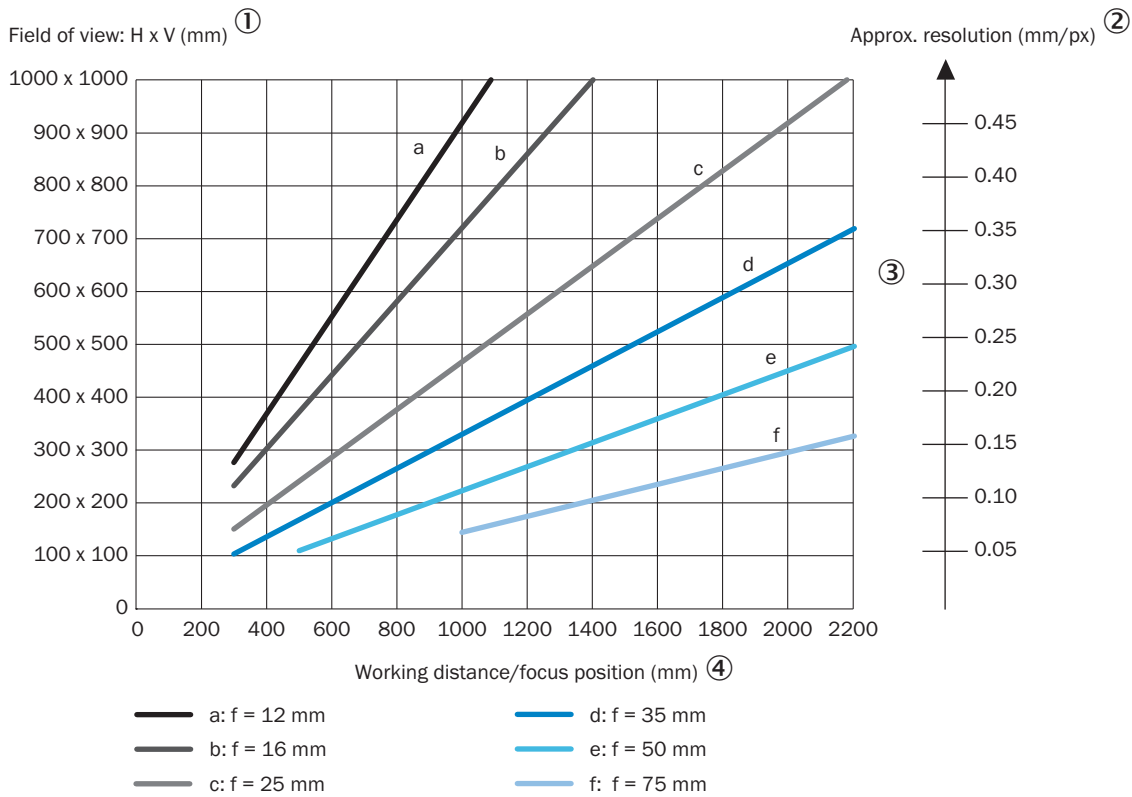

- ① Field of view: Horizontal x vertical in mm
- ② approximate resolution in mm/px
- ③ Lens focal length
- ④ Working distance/Focus position in mm

Selection Guide

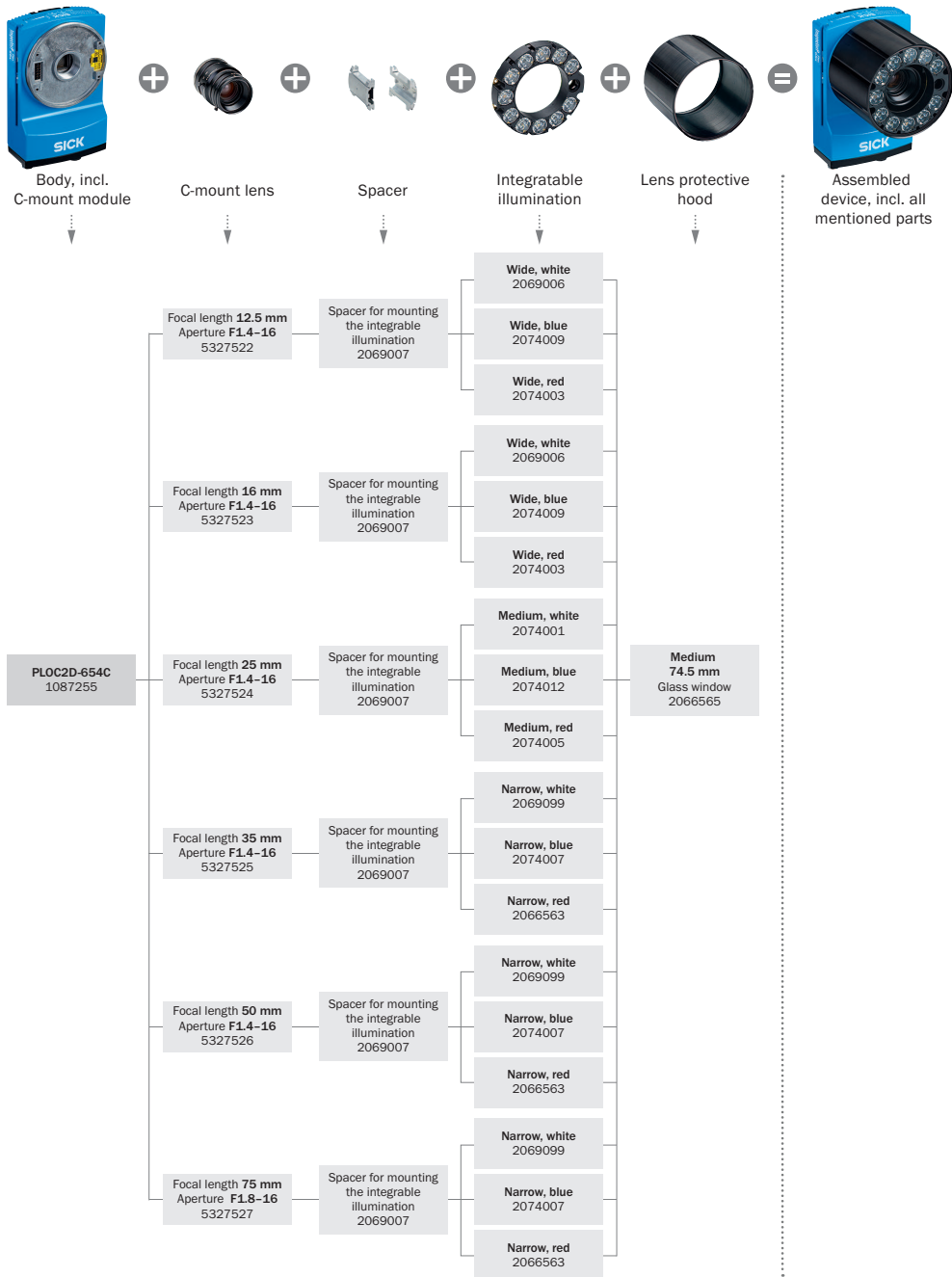

Recommended accessories

Other models and accessories → www.sick.com/PLOC2D

	Brief description	Type	part no.
Commissioning aids and test equipment			
	<ul style="list-style-type: none">• Product: Test equipment• Description: Target for alignment and calibration, A3-size	PLOC2D alignment and calibration target A3	4092645

SICK AT A GLANCE

SICK is one of the leading manufacturers of intelligent sensors and sensor solutions for industrial applications. A unique range of products and services creates the perfect basis for controlling processes securely and efficiently, protecting individuals from accidents and preventing damage to the environment.

We have extensive experience in a wide range of industries and understand their processes and requirements. With intelligent sensors, we can deliver exactly what our customers need. In application centers in Europe, Asia and North America, system solutions are tested and optimized in accordance with customer specifications. All this makes us a reliable supplier and development partner.

Comprehensive services complete our offering: SICK LifeTime Services provide support throughout the machine life cycle and ensure safety and productivity.

For us, that is “Sensor Intelligence.”

WORLDWIDE PRESENCE:

Contacts and other locations –www.sick.com