



STR1-SAXM0AC8

STR1

NON-CONTACT SAFETY SWITCHES

SICK
Sensor Intelligence.



Ordering information

Type	part no.
STR1-SAXMOAC8	1085791

Other models and accessories → www.sick.com/STR1

Illustration may differ



Detailed technical data

Features

System part	sensor
Sensor principle	RFID
Number of safe outputs	2
Auxiliary contact (AUX)	1 (Switching behavior complementary to OSSDs)
Assured switch on distance S_{ao}	14 mm (-10 ... +70 °C) ¹⁾ 10 mm (-30 ... -10 °C) ¹⁾
Assured switch off distance S_{ar}	28 mm ¹⁾
Active sensor surfaces	3
Active sensor surface	Top, sides (left, right) ²⁾
Actuation directions	5
Coding	Universally coded

¹⁾ Values apply for the frontal alignment of the sensor to the “Flat” actuator. A detailed display of the alignment options and values can be found in the operating instructions.

²⁾ For details see operating instructions.

Safety-related parameters

Safety integrity level	SIL 3 (IEC 61508)
Category	Category 4 (EN ISO 13849)
Performance level	PL e (EN ISO 13849)
PFH_D (mean probability of a dangerous failure per hour)	$5,1 \times 10^{-9}$
T_M (mission time)	20 years (EN ISO 13849)
Type	Type 4 (EN ISO 14119)
Actuator coding level	Low coding level (EN ISO 14119)
Safe state in the event of a fault	At least one safety-related semiconductor output (OSSD) is in the OFF state.

Functions

Safe series connection	With T-connector (without diagnostics)
-------------------------------	--

With Flexi Loop (with diagnostics)

Interfaces

Connection type	Cable with plug M12, 8-pin
Length of cable	0.2 m
Long connecting cable	≤ 200 m
Cable diameter	5.5 mm
Conductor cross section	0.12 mm ²
Bend radius (with fixed installation)	> 8 x cable diameter
Bend radius (with moving cable)	> 12 x cable diameter
Cable material	PVC
Conductor material	Copper
Coupling nut material	Zinc die-cast, nickel-plated
Display elements	LEDs
Diagnostics indicator	✓
Status display	✓

Electronics

Protection class	III (IEC 61140)
Classification according to cULus	Class 2
Supply voltage V_s	24 V DC (19.2 V DC ... 28.8 V DC)
Power consumption	50 mA
Type of output	Self-monitoring semiconductor outputs (OSSDs)
Output current	≤ 100 mA
Response time	40 ms ¹⁾
Release time	100 ms ^{1) 2)}
Risk time	80 ms ^{1) 3)}
Switch-on time	2.5 s ⁴⁾

¹⁾ In a safe series connection, each downstream safety switch increases the system response time. More response times can be found in the operating instructions.

²⁾ Response time on approach to the enable zone.

³⁾ Detection time for internal oder external faults (e.g., short-circuit or cross-circuit of output signal switching devices). Follow the detailed information in the operating instructions.

⁴⁾ The time specified applies to one sensor after the supply voltage has been applied to the safety switch. In a safe series connection, 0.1-s must be added for each sensor. An additional 0.5-s per taught-in actuator must be added for uniquely coded and permanently coded sensors.

Mechanics

Dimensions (W x H x D)	40 mm x 18 mm x 26 mm
Weight	50 g
Housing material	VISTAL®

Ambient data

Enclosure rating	IP67, IP69K (EN 60529, ISO 20653)
Ambient operating temperature	-30 °C ... +70 °C ¹⁾
Storage temperature	-30 °C ... +70 °C

¹⁾ Only applies for safety switches whose serial numbers begin with number series 1825**** or higher. For safety switches whose serial numbers deviate from this, an ambient operating temperature of -10 °C ... +70 °C applies.
The serial number is displayed on the safety switch over the data matrix code.

Vibration resistance	10 Hz ... 55 Hz, 1 mm (IEC 60068-2-6)
Shock resistance	30 g, 11 ms (IEC 60068-2-27)
EMC	EN IEC 61326-3-1 EN IEC 60947-5-2 EN IEC 60947-5-3 EN 300330 V2.1.1

¹⁾ Only applies for safety switches whose serial numbers begin with number series 1825**** or higher. For safety switches whose serial numbers deviate from this, an ambient operating temperature of -10 °C ... +70 °C applies.
The serial number is displayed on the safety switch over the data matrix code.

Certificates

EU declaration of conformity	✓
UK declaration of conformity	✓
ACMA declaration of conformity	✓
China RoHS	✓
cULus certificate	✓
TÜV approval	✓
TÜV approval annex	✓
EC-Type-Examination approval	✓

Classifications

ECLASS 5.0	27272403
ECLASS 5.1.4	27272403
ECLASS 6.0	27272403
ECLASS 6.2	27272403
ECLASS 7.0	27272403
ECLASS 8.0	27272403
ECLASS 8.1	27272403
ECLASS 9.0	27272403
ECLASS 10.0	27272403
ECLASS 11.0	27272403
ECLASS 12.0	27274601
ETIM 5.0	EC001829
ETIM 6.0	EC001829
ETIM 7.0	EC001829
ETIM 8.0	EC001829
UNSPSC 16.0901	39122205

Dimensional drawing Sensor with cable and male connector

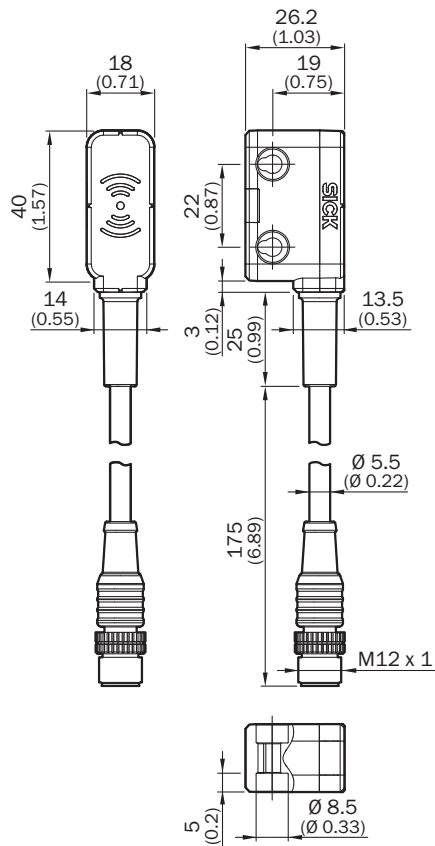

Dimensions in mm (inch)

Response range "Flat"/"Mini" actuator, active side sensor surface

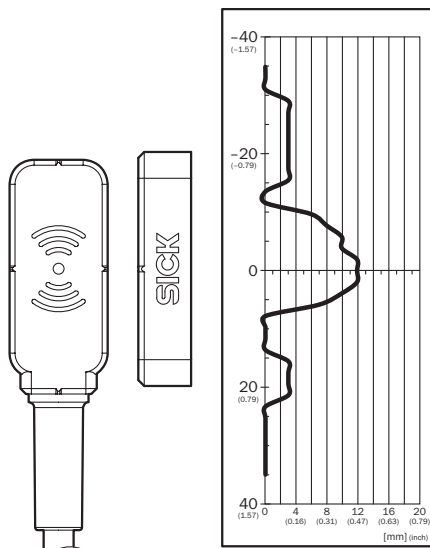

Assured switch on distance S_{ao} 9 mm. Observe border areas for parallel approach: a minimum distance of 4 mm (typical) must be upheld when the actuator moves laterally to the sensor surface. This prevents early triggering due to the side preparation areas.

Response range "Flat"/"Mini" actuator, active front sensor surface



Assured switch on distance S_{ao} 14 mm. Observe border areas for parallel approach: a minimum distance of 10 mm (typical) must be upheld when the actuator moves laterally to the sensor surface. This prevents early triggering due to the side preparation areas.

Response range "Standard" actuator, active side sensor surface

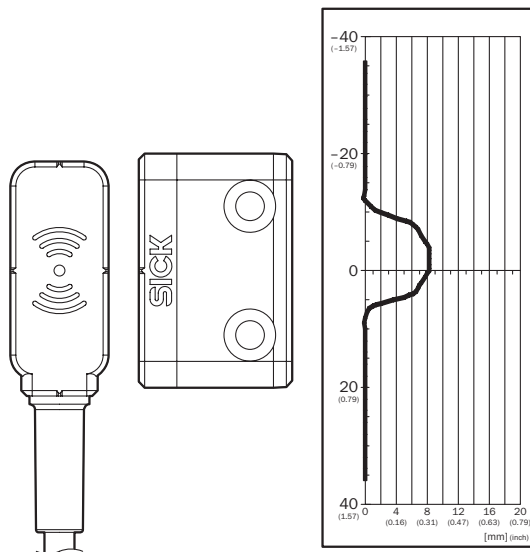

assured switch on distance S_{ao} 6 mm

Response range "Standard" actuator, active front sensor surface

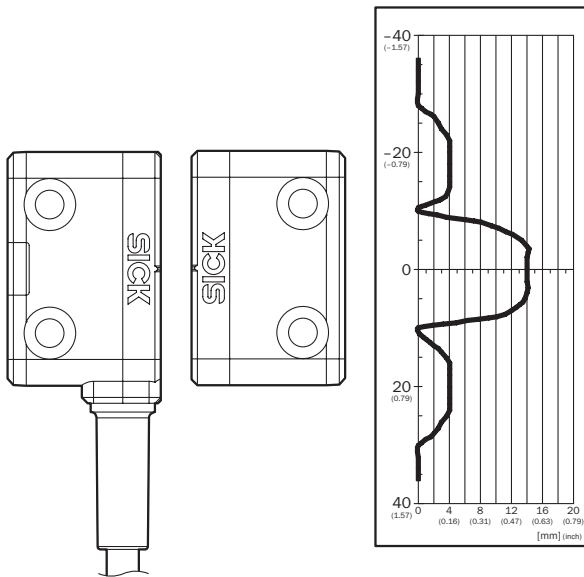

Assured switch on distance S_{ao} 10 mm. Observe border areas for parallel approach: a minimum distance of 6 mm (typical) must be upheld when the actuator moves laterally to the sensor surface. This prevents early triggering due to the side preparation areas.

Pinouts

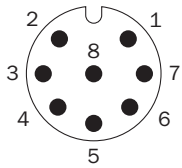

1	Aux output (not safe)
2	Voltage supply 24 V DC
3	Not connected
4	Enable input for OSSD 2
5	OSSD 1
6	OSSD 2
7	Voltage supply 0 V DC
8	Enable input for OSSD 1

Connection single sensor

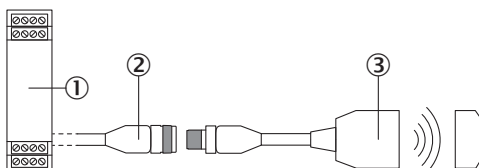

- ① Safe evaluation unit
- ② connecting cable with M12 female connector, 8-pin and flying leads (e.g. YF2A18-xxxUA5LEAX)
- ③ STR1 RFID safety switch (e.g., STR1-SAx0AC8)

Series connection with T-piece (without diagnostics)

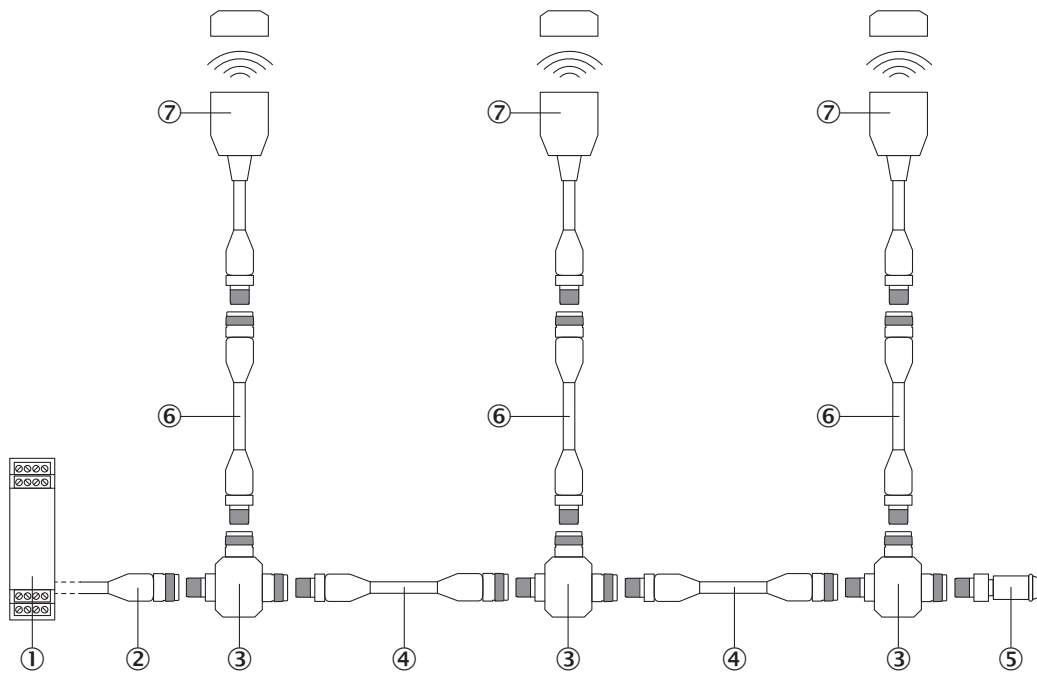

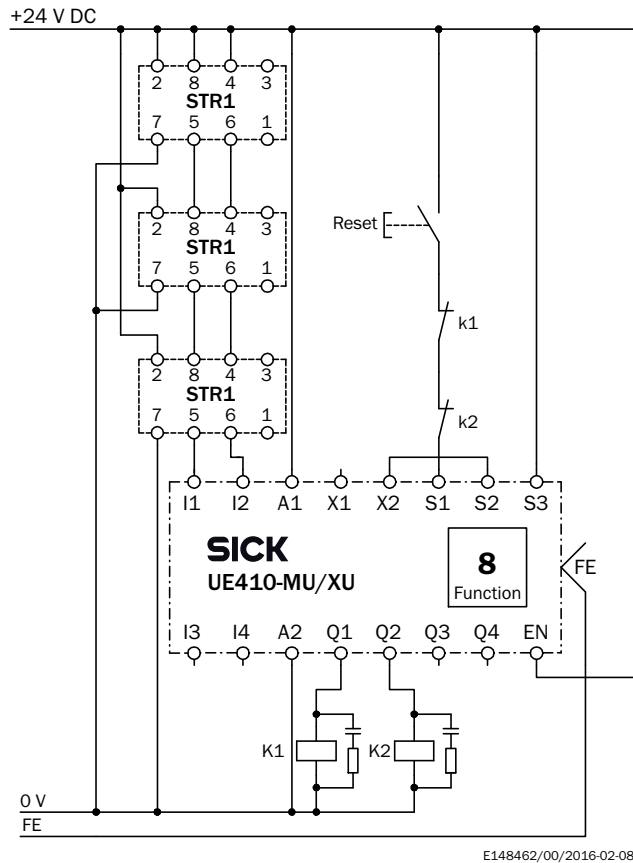

- ① Safe evaluation unit
- ② connecting cable with M12 female connector, 4-pin and flying leads (e.g. YF2A14-xxxVB3XLEAX)
- ③ STR1-XXA T-connector
- ④ Connection cable with 4-pin, M12 male connector and 4-pin, M12 female connector (e.g., YF2A14-xxxVB3M2A14)
- ⑤ MLP1-XXT end connector
- ⑥ Connection cable with 8-pin, M12 male connector and 8-pin, M12 female connector (e.g., YF2A18-xxxUA5M2A18)
- ⑦ STR1 RFID safety switch (e.g., STR1-SAx0AC8)

Connection diagram Series connection of three STR1 RFID safety switches to a Flexi Classic safety controller



Recommended accessories

Other models and accessories → www.sick.com/STR1

	Brief description	Type	part no.
connectors and cables			
	<ul style="list-style-type: none"> Description: Sensor/actuator cable, unshielded Connection type head A: Female connector, M12, 8-pin, straight, A-coded Connection type head B: Flying leads Signal type: Sensor/actuator cable Cable: 2 m, 8-wire, PUR, halogen-free Application: Drag chain operation, Zones with oils and lubricants, Robot, Drag chain operation 	YF2A18-020UA5XLEAX	2095652
	<ul style="list-style-type: none"> Description: Sensor/actuator cable, unshielded Connection type head A: Female connector, M12, 8-pin, straight, A-coded Connection type head B: Flying leads Signal type: Sensor/actuator cable Cable: 5 m, 8-wire, PUR, halogen-free Application: Drag chain operation, Zones with oils and lubricants, Robot, Drag chain operation 	YF2A18-050UA5XLEAX	2095653
	<ul style="list-style-type: none"> Description: Sensor/actuator cable, unshielded Connection type head A: Female connector, M12, 8-pin, straight, A-coded Connection type head B: Flying leads Signal type: Sensor/actuator cable Cable: 10 m, 8-wire, PUR, halogen-free Application: Drag chain operation, Zones with oils and lubricants, Robot, Drag chain operation 	YF2A18-100UA5XLEAX	2095654

SICK AT A GLANCE

SICK is one of the leading manufacturers of intelligent sensors and sensor solutions for industrial applications. A unique range of products and services creates the perfect basis for controlling processes securely and efficiently, protecting individuals from accidents and preventing damage to the environment.

We have extensive experience in a wide range of industries and understand their processes and requirements. With intelligent sensors, we can deliver exactly what our customers need. In application centers in Europe, Asia and North America, system solutions are tested and optimized in accordance with customer specifications. All this makes us a reliable supplier and development partner.

Comprehensive services complete our offering: SICK LifeTime Services provide support throughout the machine life cycle and ensure safety and productivity.

For us, that is “Sensor Intelligence.”

WORLDWIDE PRESENCE:

Contacts and other locations –www.sick.com