

SICK.COM



DATA SHEET

V2D631D-MXSXB0

Lector63x
Image-based code readers

SICK Sensor Intelligence

IMAGE-BASED CODE READERS

V2D631D-MXSXB0

ORDERING INFORMATION

Type	part no.
V2D631D-MXSXB0	1082395

Further device versions and accessories at www.sick.com/Lector63x



DETAILED TECHNICAL DATA

FEATURES

Variant	Main unit
Optical focus	Adjustable focus (manual)
Sensor	CMOS monochrome
Sensor resolution	1,280 px x 1,024 px (1.3 MP)
Illumination	To be ordered separately as accessories
Alignment aid	Laser, Red, 630 nm ... 680 nm
Laser class	1, Complies with 21 CFR 1040.10 and 1040.11 except for conformance with IEC 60825-1 Ed.3., as described in "Laser Notice No. 56" dated May 8, 2019 (IEC 60825-1:2014, EN 60825-1:2014+A11:2021)
Lens	S-mount
	Optical format 1/1.8"
	Note To be ordered separately as accessories
Scanning frequency	≤ 50 Hz, With resolution of 1.3 megapixels
Code resolution	≥ 0.1 mm ¹⁾
Working range	50 mm ... 2,200 mm ^{2) 3)}

¹⁾ Depends on lens used, for details see field of view diagram.

²⁾ Depends on lens used.

³⁾ For details see field of view diagram.

MECHANICS/ELECTRONICS

Connection type	1 x M12, 17-pin plug (serial, CAN, I/Os, power supply) 1 x M12, 8-pin socket (Ethernet, 1 GBit/s)
-----------------	------------------------------------------------------------------------------------------------------

¹⁾ Housing only, without lens and optics protection hood.

	1 x M8, 4-pin socket (USB) 1 x M12, 4-pin socket (external illumination control)
Supply voltage	12 V DC ... 24 V DC, ± 20 %
Power consumption	Typ. 10 W, ± 20 %
Output current	≤ 100 mA
Housing material	Aluminum die cast
Window material	Plastic (To be ordered separately as accessories) Glass (To be ordered separately as accessories)
Enclosure rating	IP67 (EN 60529 (1991-10), EN 60529/A2 (2002-02))
Electrical safety	EN 60950-1 (2011-01)
Weight	430 g, without lens and connection cables
Dimensions (L x W x H)	108 mm x 63.1 mm x 45.8 mm ¹⁾

¹⁾ Housing only, without lens and optics protection hood.

PERFORMANCE

Readable code structures	1D codes, Stacked, 2D codes, direct-marked codes
Bar code types	GS1-128 / EAN 128, UPC / GTIN / EAN, Interleaved 2 of 5, Pharmacode, GS1 DataBar, Code 39, Code 128, Codabar, Code 32, Code 93, USPS (Postnet, Planet, USPS4SCB), Australian Post, Dutch KIX Post, Royal Mail, Swedish Post
2D code types	Data Matrix ECC200, GS1 Data-Matrix, MaxiCode, QR code
Stacked code types	PDF417
Code qualification	On the basis of ISO/IEC 16022, ISO/IEC 15415, ISO/IEC 18004

INTERFACES

Ethernet	Function	✓, TCP/IP
	Data transmission rate	Data interface (read result output), Service interface, FTP (image transmission) 10/100/1,000 Mbit/s
PROFINET	Function	✓
	Data transmission rate	PROFINET Single Port (integrated), PROFINET Dual Port (optional via external connection module CDF600-2) 10/100 MBit/s
EtherNet/IP™	Function	✓
	Data transmission rate	10/100/1,000 Mbit/s
Serial	Function	✓, RS-232, RS-422
	Data transmission rate	Data interface (read result output), Service interface 0.3 kBaud ... 115.2 kBaud, AUX: 57.6 kBaud (RS-232)
CAN	Function	✓
	Data transmission rate	SICK CAN sensor network CSN (CAN controller/CAN device, multiplexer/server) 250 kbit/s ... 500 kbit/s
PROFIBUS DP	Function	✓
	Type of fieldbus integration	Optional over external fieldbus module CDF600-2
Digital inputs		4 ("Sensor 1", "Sensor 2", 2 inputs via optional CMC600 parameter memory in CDB650/CDM420)
Configurable inputs		Encoder input, external trigger
Digital outputs		6 (CDB650: "Result 1", "Result 2", "Result 3", "Result 4", 2 external outputs via CMC600 or CDM420: "Result 1", "Result 2", 2 external outputs via CMC600 or cable with open end: "Result 1", "Result 2", "Result 3", "Result 4")
Configurable outputs		Good read, External illumination control, free configurable output condition, "device ready"
Reading pulse		Digital inputs, non-powered, serial interface, Ethernet, CAN, auto pulse, presentation mode
Optical indicators		11 LEDs (5 status displays, 16 LEDs, 5 LED bar graphs, 1 green/red feedback spot)
Acoustic indicators		Beeper (configurable)
Control elements		2 buttons (choose and start/stop functions)
Operator interfaces		Web server
Configuration software		SOPAS ET
Memory card		Micro SD memory card (flash card) max. 32 GB, optional

Data storage and retrieval	Image and data storage via microSD memory card and external FTP
EncoderFrequency	Max. 1 kHz
External illumination control	Via digital output (max. 24 V trigger) or external illumination connection

AMBIENT DATA

Electromagnetic compatibility (EMC)	EN 61000-6-2:2005-08 / EN 61000-6-4 (2007-01) + A1 (2011)
Vibration resistance	EN 60068-2-6:2008-02
Shock resistance	EN 60068-2-27:2009-05
Ambient operating temperature	0 °C ... +50 °C
Storage temperature	-20 °C ... +70 °C
Relative humidity	90 %, Non-condensing

CERTIFICATES

EU declaration of conformity	✓
UK declaration of conformity	✓
ACMA declaration of conformity	✓
China RoHS	✓
cULus certificate	✓
Profinet certificate	✓
Information according to Art. 3 of Data Act (Regulation EU 2023/2854)	✓

DIMENSIONAL DRAWING

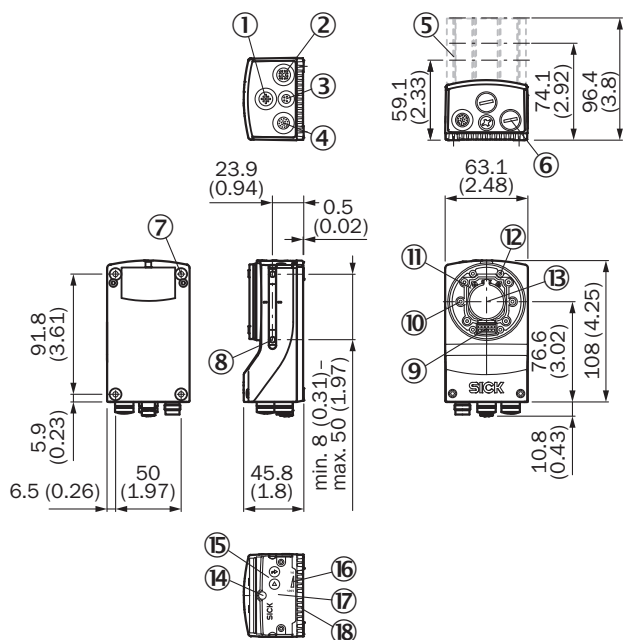

Dimensions in mm (inch)

- ① “External light” connection (external illumination unit, female connector, M12, 4-pin, A-coded)
- ② “Ethernet” connection (Gigabit Ethernet, female connector, M12, 8-pin, X-coded)
- ③ “USB” connection (female connector, type M8, 4-pin), for temporary use as a service interface only
- ④ “Power/Serial Data/CAN/I/O” connection (male connector, M12, 17-pin, A-coded)
- ⑤ Optics protection hood (length: 22.7 mm, 37.7 mm or 60 mm)
- ⑥ 4 protective caps for sealing off the electrical connections as required for enclosure rating IP67 (delivery condition)
- ⑦ 4 tapped blind holes, M5, 5.5 mm deep for mounting the product
- ⑧ 2 M5 sliding nuts; 5.5 mm deep; pivoting; as an alternative method of mounting the product
- ⑨ Connection for an integrable illumination unit (VI55I ring illumination unit)
- ⑩ 2 laser alignment aids
- ⑪ S-mount or C-mount optics module
- ⑫ 4 blind tapped holes, 2.5 mm for mounting the spacers for the integrable illumination (VI55I ring illumination unit)
- ⑬ Optical axis and center of the image sensor
- ⑭ Basic device: Manual focus screw for an S-mount lens, accessible via the round opening in the housing cover. To secure the focus setting, cover the round opening with a self-adhesive label. Complete device: The opening is already covered by a label.
- ⑮ 2 function keys
- ⑯ 5 bar graph LEDs
- ⑰ Hinged cover on the top side of the device, access to the microSD memory card and the manual focus screw (S-mount)
- ⑱ 5 status LEDs (2 levels)

FIELD OF VIEW

Perceived area of field of view: H x V (mm) ①

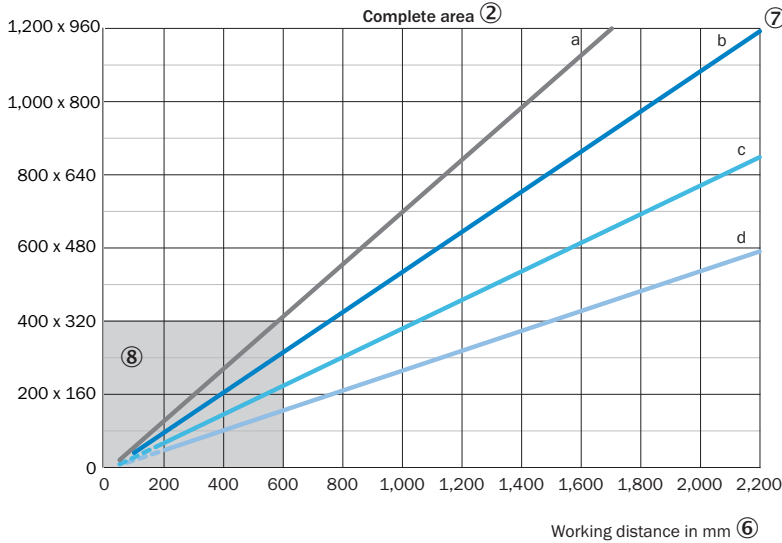

Min. resolution in mm ③
 1D code ④ 2D code ⑤

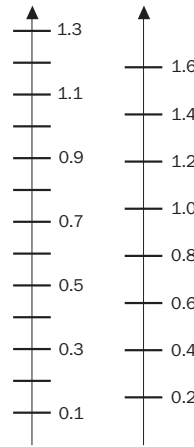

Perceived area of field of view: H x V (mm) ①

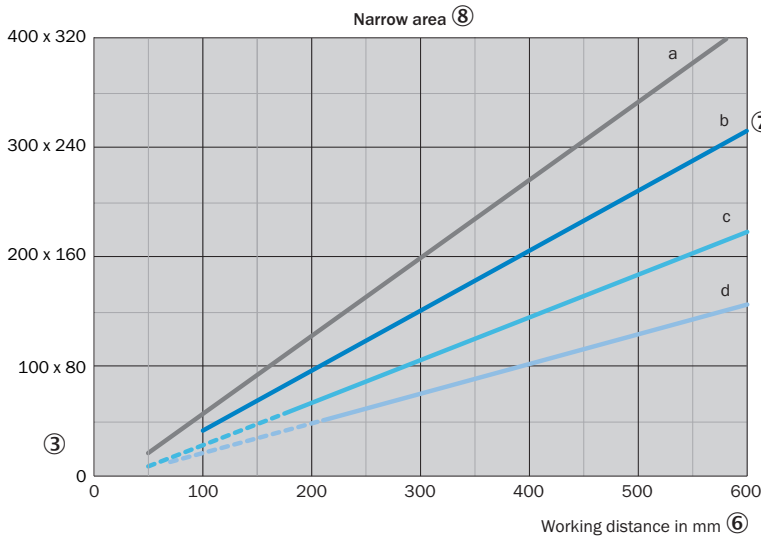

Min. resolution in mm ③
 1D code ④ 2D code ⑤

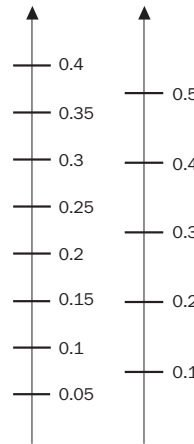

- a: f = 9.6 mm — c: f = 17.5 mm
- b: f = 12.5 mm — d: f = 25.0 mm
- - - Optional spacer rings required ⑨

For S-mount and standard C-mount lenses, spacer rings are needed for working distances shorter than approximately 10 times the focal length. For compact C-mount lenses, spacer rings are not needed, but the built-in illumination cannot be used for distances shorter than 300 mm.

- ① perceived field of view area: horizontal x vertical (mm)
- ② complete area
- ③ Minimum resolution in mm
- ④ 1D code
- ⑤ 2D code
- ⑥ Working distance in mm
- ⑦ Focal length of lens, here example for f = 12.5 mm
- ⑧ Close range
- ⑨ Optional spacer ring required

SELECTION GUIDE LECTOR63X S-MOUNT

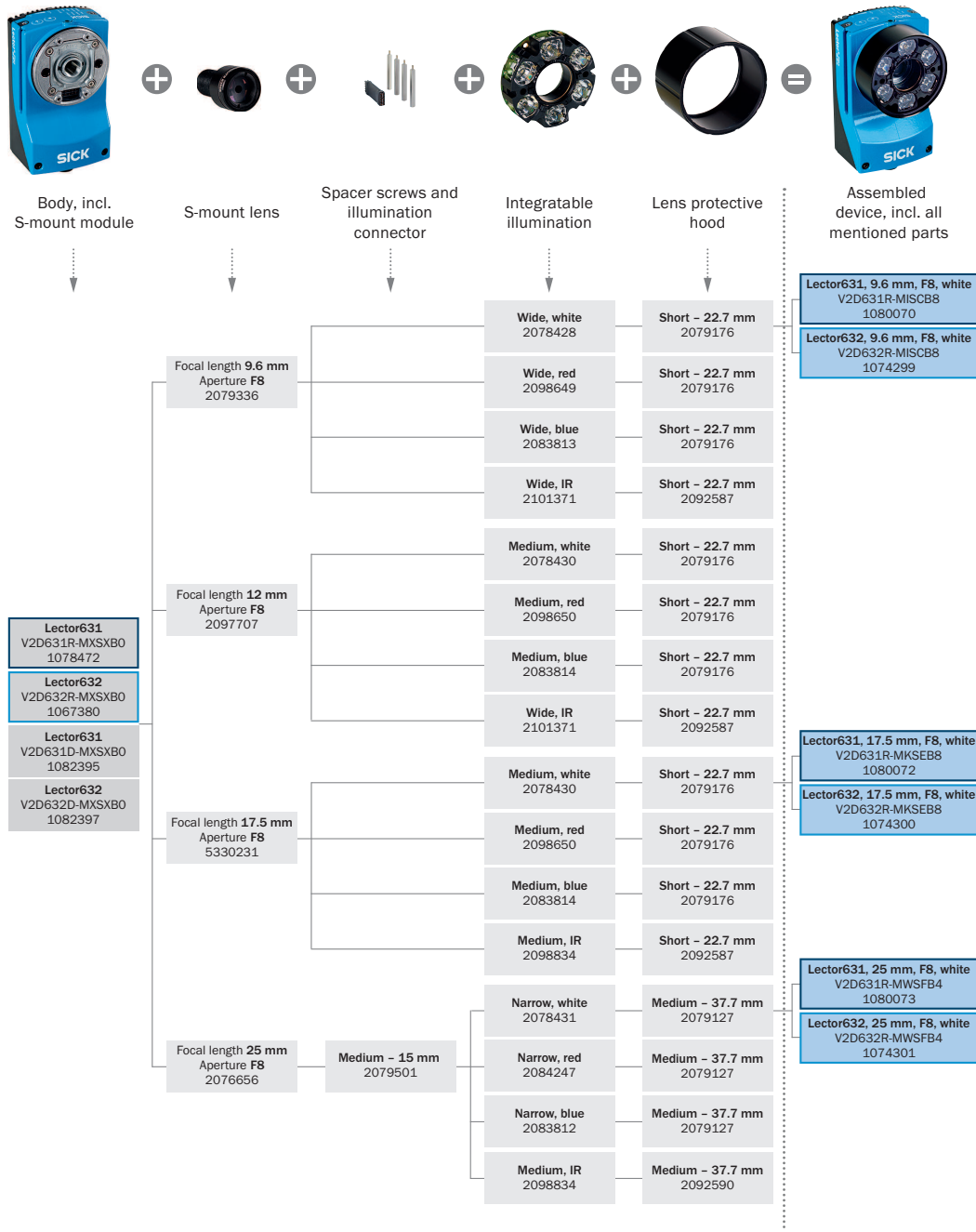

EXPLODED VIEW

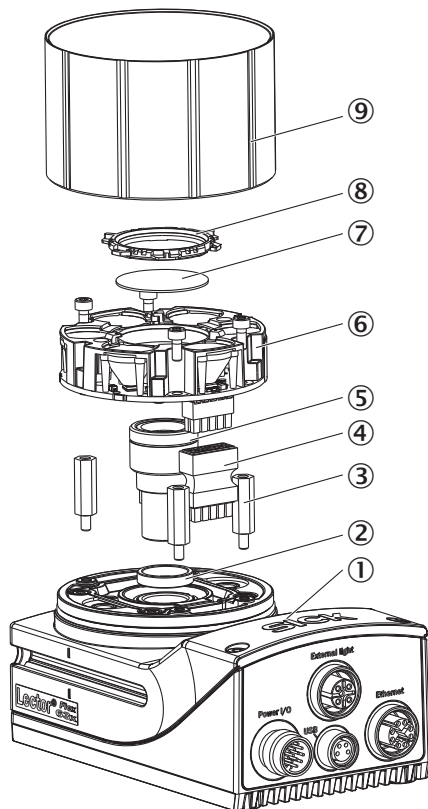

- ① Camera housing
- ② Spacer for built-in illumination
- ③ Spacer ring (optional)
- ④ Plug connector for illumination
- ⑤ S-mount lens
- ⑥ Built-in illumination
- ⑦ Optical filter (optional)
- ⑧ Filter holder
- ⑨ optics protection hood

Further information as well as suitable accessories, example applications and downloads such as CAD dimensional models, operating instructions and software can be found at www.sick.com/1082395



SICK AG
WALDKIRCH
GERMANY
SICK.COM

SICK AT A GLANCE

SICK is a leading global technology company for intelligent sensors and integrated solutions in industrial automation. Our technologies set benchmarks, making your industrial processes more efficient, safer and more sustainable – both in logistics and manufacturing operations.

SICK combines sensor intelligence with industry expertise and certified consulting services. We provide the ideal foundation for scalable as well as tailor-made automation solutions and create added value along the entire value chain. Our close partnerships with our customers are more than just a promise: Together, we optimize productivity, improve quality, protect health and safety, and help build a sustainable future. All with empathy and trust.

Since 1946, we have been developing innovative technologies with passion and a pioneering spirit. With a global network in around 40 countries, SICK has a global presence and is always close by. The company's headquarters are located in Waldkirch near Freiburg, Germany. Our customers benefit from our understanding of both local and global requirements, which enables us to deliver tailor-made solutions

SICK
Sensor Intelligence