



# MLP1-SMMCOAC

MLP1

SAFETY LOCKING DEVICES

**SICK**  
Sensor Intelligence.



### Ordering information

Type	part no.
MLP1-SMMC0AC	1077942

Other models and accessories → [www.sick.com/MLP1](http://www.sick.com/MLP1)



### Detailed technical data

#### Features

<b>Sensor principle</b>	RFID
<b>Locking principle</b>	Power to lock
<b>Coding</b>	Universally coded
<b>Locking force <math>F_{max}</math></b>	550 N (GS-ET-19)
<b>Locking force <math>F_{Zh}</math></b>	500 N (GS-ET-19)
<b>Retaining force</b>	25 N
<b>Offset tolerance</b>	≤ 5 mm
<b>Assured switch off distance <math>S_{ar}</math></b>	45 mm
<b>For process protection only</b>	✓

#### Safety-related parameters

<b>Safety integrity level</b>	SIL 3 (IEC 61508)
<b>Category</b>	Category 4 (EN ISO 13849)
<b>Performance level</b>	PL e (EN ISO 13849) <sup>1)</sup>
<b>PFH<sub>D</sub> (mean probability of a dangerous failure per hour)</b>	$15 * 10^{-9}$ <sup>2)</sup>
<b>T<sub>M</sub> (mission time)</b>	20 years (EN ISO 13849)
<b>Type</b>	Type 4 (EN ISO 14119)
<b>Actuator coding level</b>	Low coding level (EN ISO 14119)
<b>Safe state in the event of a fault</b>	At least one safety-related semiconductor output (OSSD) is in the OFF state.

<sup>1)</sup> In a safe series connection, the performance level for the safe series connection as a whole depends on the number and type of devices in the safe series connection. PL e is only possible in safe series connections with a maximum of 6 devices.

<sup>2)</sup> At 40 °C and 1000 m above sea level.

#### Functions

<b>Switching behavior of the OSSDs</b>	Actuator monitoring
--	---------------------

<b>Safe series connection</b>	Direct (without diagnostics)
-------------------------------	------------------------------

## Interfaces

<b>Connection type</b>	Cable with plug, M12, 5-pin and cable with socket, M12, 5-pin
Length of cable	150 mm
Long connecting cable	≤ 140 m
Cable diameter	5.5 mm
Conductor cross section	0.12 mm <sup>2</sup>
Bend radius (with fixed installation)	> 8 x cable diameter
Bend radius (with moving cable)	> 12 x cable diameter
Cable material	PVC
Conductor material	Copper
Coupling nut material	Zinc die-cast, nickel-plated
<b>Display elements</b>	LEDs
Status display	✓

## Electronics

<b>Protection class</b>	III (IEC 61140)
<b>Contamination rating</b>	3 (EN 60947-1)
<b>Classification according to cULus</b>	Class 2
<b>Usage category</b>	DC-13 (IEC 60947-5-1)
<b>Rated insulation voltage U<sub>i</sub></b>	32 V
<b>Rated impulse withstand voltage U<sub>imp</sub></b>	1,500 V
<b>Supply voltage U<sub>v</sub> when an individual safety switch is connected</b>	
Sensor	24 V DC (19.2 V DC ... 28.8 V DC)
Magnet	24 V DC (19.2 V DC ... 28.8 V DC)
<b>Supply voltage U<sub>v</sub> when a cascade is connected</b>	
Sensor	24 V DC (22.8 V DC ... 28.8 V DC)
Magnet	24 V DC (21.6 V DC ... 28.8 V DC)
<b>Power consumption</b>	
Locking active	350 mA
Locking deactivated	50 mA
<b>Switching frequency</b>	≤ 0.5 Hz
<b>Type of output</b>	Self-monitoring semiconductor outputs (OSSDs)
<b>Output current (OSSDs)</b>	≤ 100 mA
<b>Diagnostic output</b>	≤ 25 mA, short-circuit protected
<b>Cable capacitance</b>	400 nF (for OUT A and OUT B)
<b>Response time</b>	50 ms <sup>1)</sup>
<b>Release time</b>	100 ms <sup>1)</sup>
<b>Risk time</b>	100 ms <sup>1)</sup>

<sup>1)</sup> In a cascade, the value is multiplied by the number of safety switches in the cascade.

<b>Switch-on time</b>	2.5 s
<b>Locking principle</b>	Power to lock

<sup>1)</sup> In a cascade, the value is multiplied by the number of safety switches in the cascade.

## Mechanics

<b>Weight</b>	Switches (spare parts)	510 g
	Actuator	210 g
<b>Material</b>	Sensor housing	Anodized aluminum
	Actuator housing	Fiber-glass-reinforced PVC
	Anchor plate	Nickel-plated steel
<b>Dimensions (W x H x D)</b>	Switches (spare parts)	120 mm x 60 mm x 38.5 mm
	Actuator	120 mm x 60 mm x 20.5 mm
<b>Offset tolerance</b>	Vertical	≤ 5 mm
	Horizontal	≤ 5 mm
	Aperture angle	≤ 3°

## Ambient data

<b>Enclosure rating</b>	IP67 (EN 60529)
<b>Ambient operating temperature</b>	-20 °C ... +55 °C
<b>Storage temperature</b>	-25 °C ... +70 °C
<b>Relative humidity</b>	50 %, at 70 °C (IEC 60947-5-2)
<b>Vibration resistance</b>	10 Hz ... 55 Hz, 1 mm (IEC 60068-2-6)
<b>Shock resistance</b>	30 g, 11 ms (EN 60068-2-27)
<b>EMC</b>	EN IEC 61326-3-1 EN IEC 60947-5-2 EN IEC 60947-5-3

## Certificates

<b>EU declaration of conformity</b>	✓
<b>UK declaration of conformity</b>	✓
<b>ACMA declaration of conformity</b>	✓
<b>China RoHS</b>	✓
<b>UK-Type-Examination approval</b>	✓
<b>cULus certificate</b>	✓
<b>FCC certificate</b>	✓
<b>TÜV approval</b>	✓
<b>TÜV approval annex</b>	✓
<b>EC-Type-Examination approval</b>	✓

## Classifications

<b>ECLASS 5.0</b>	27272603
-------------------	----------

<b>ECLASS 5.1.4</b>	27272603
<b>ECLASS 6.0</b>	27272603
<b>ECLASS 6.2</b>	27272603
<b>ECLASS 7.0</b>	27272603
<b>ECLASS 8.0</b>	27272603
<b>ECLASS 8.1</b>	27272603
<b>ECLASS 9.0</b>	27272603
<b>ECLASS 10.0</b>	27272603
<b>ECLASS 11.0</b>	27272603
<b>ECLASS 12.0</b>	27272603
<b>ETIM 5.0</b>	EC002593
<b>ETIM 6.0</b>	EC002593
<b>ETIM 7.0</b>	EC002593
<b>ETIM 8.0</b>	EC002593
<b>UNSPSC 16.0901</b>	39122205

Dimensional drawing Recess for flush mounting

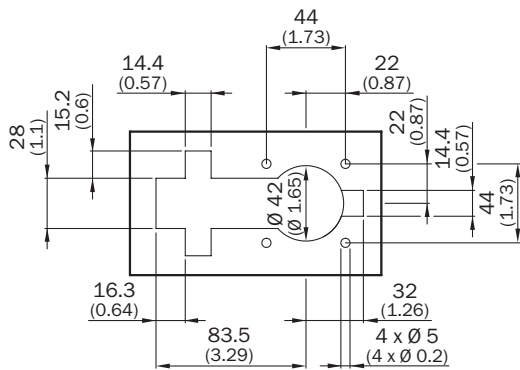

Dimensions in mm (inch)

Dimensional drawing Actuator

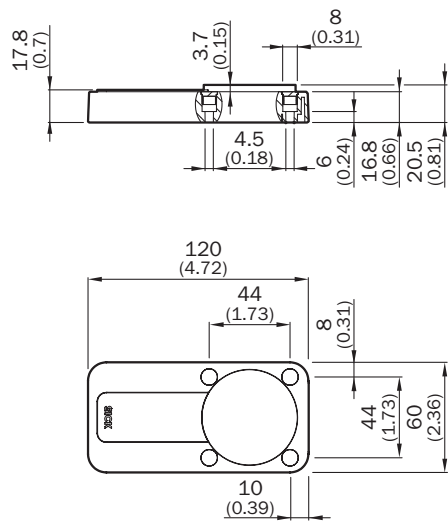

Dimensions in mm (inch)

Dimensional drawing Sensor with M12 male connector and M12 socket

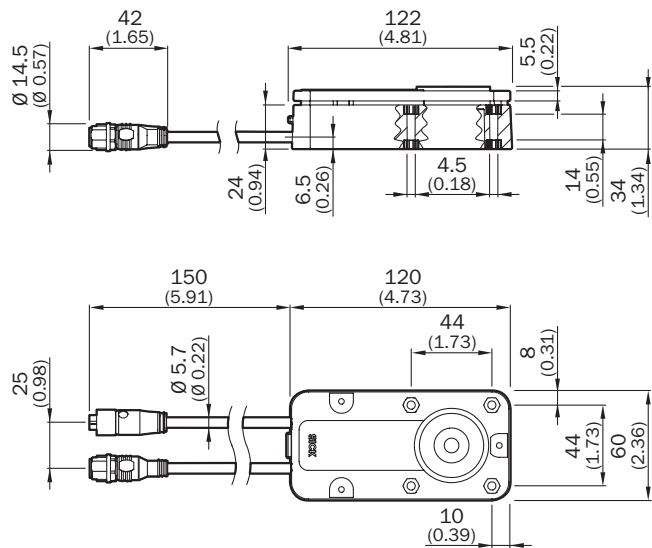

Dimensions in mm (inch)

Series connection Combining connection methods as desired

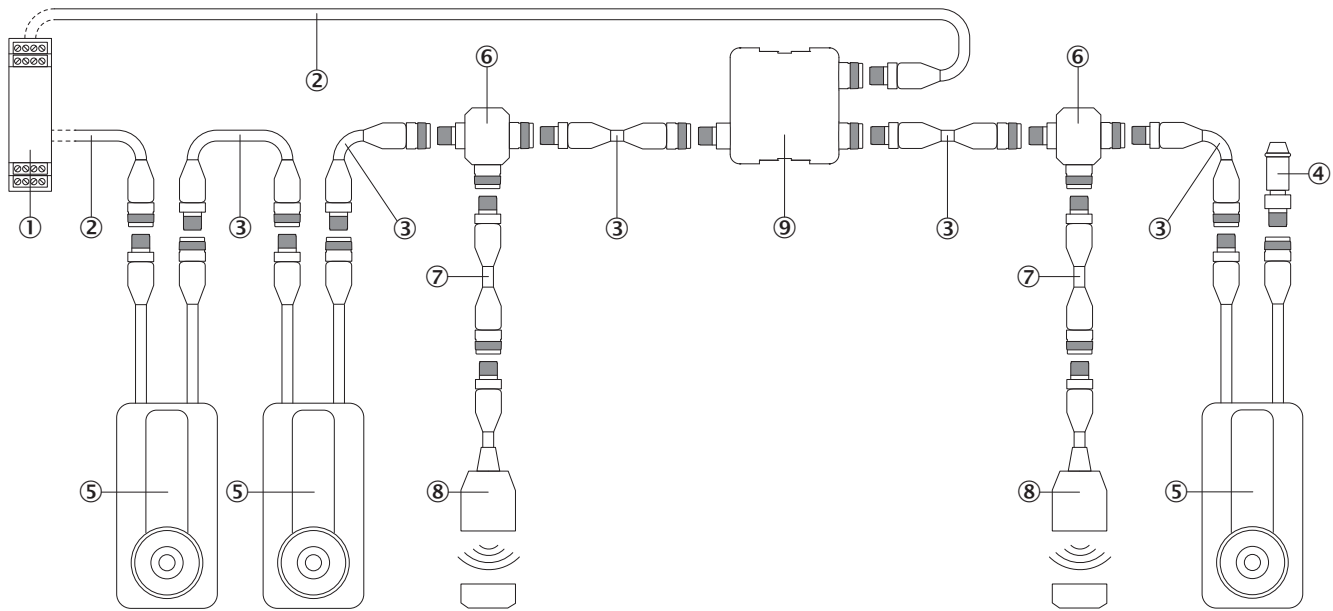

- ① Safe evaluation unit
- ② connecting cable with M12 female connector, 5-pin and flying leads (e.g., YF2A15-xxxVB5XLEAX)
- ③ Connection cable with 5-pin, M12 male connector and 5-pin, M12 female connector (e.g., YF2A15-xxxUB5M2A15)
- ④ End plug
- ⑤ MLP1 safety switch
- ⑥ T-piece
- ⑦ Connection cable with 8-pin, M12 male connector and 8-pin, M12 female connector (e.g., YF2A18-xxxUA5M2A18)
- ⑧ Safety switch, M12, 8-pin
- ⑨ Nodes for voltage supply

Series connection Connecting an additional voltage supply

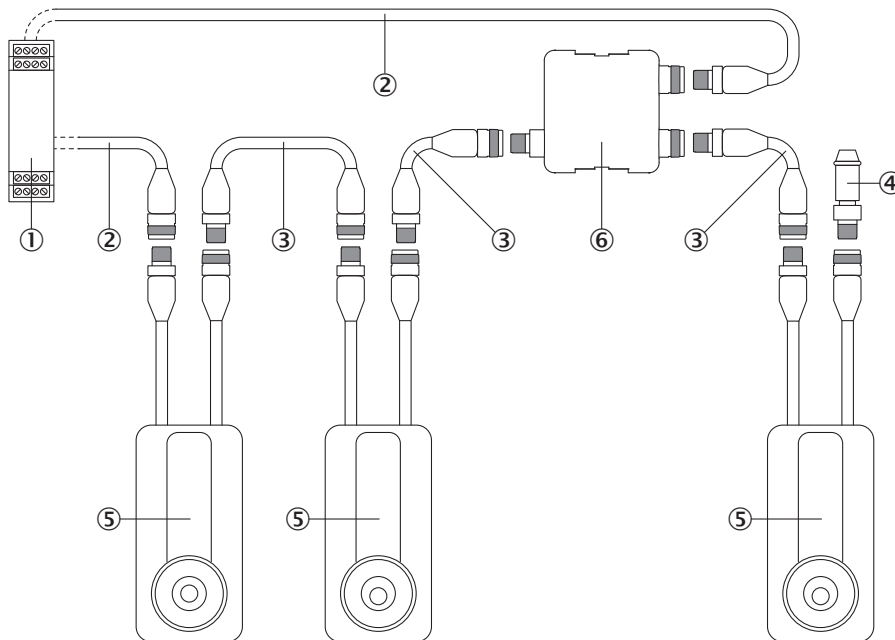

- ① Safe evaluation unit

- ② connecting cable with M12 female connector, 5-pin and flying leads (e.g., YF2A15-xxxVB5XLEAX)
- ③ Connection cable with 5-pin, M12 male connector and 5-pin, M12 female connector (e.g., YF2A15-xxxUB5M2A15)
- ④ End plug
- ⑤ MLP1 safety switch (2 × M12, 5-pin)
- ⑥ Nodes for voltage supply

### Series connection Connecting directly connected safety switches

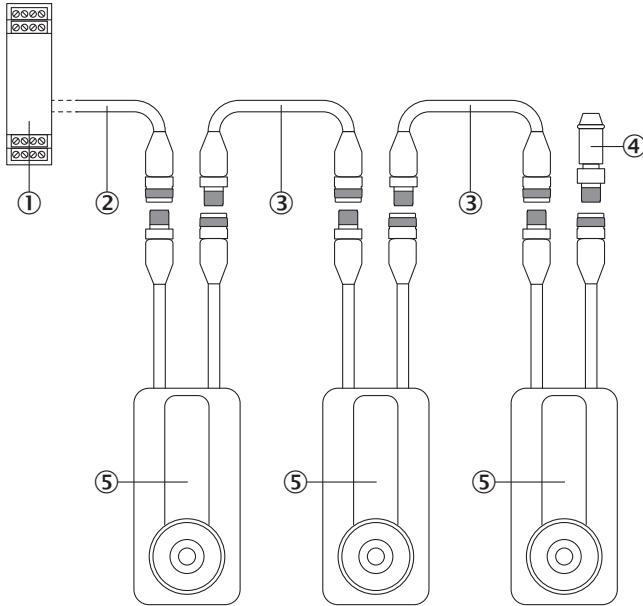

- ① Safe evaluation unit
- ② connecting cable with M12 female connector, 5-pin and flying leads (e.g., YF2A15-xxxVB5XLEAX)
- ③ Connection cable with 5-pin, M12 male connector and 5-pin, M12 female connector (e.g., YF2A15-xxxUB5M2A15)
- ④ End plug
- ⑤ MLP1 safety switch (2 × M12, 5-pin)

### Pinouts

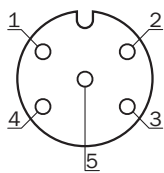

Pin	Designation	Description
1	Out 24 V DC	Safety switch voltage supply
2	In 1	Input OSSD 1
3	0 V	0 V DC voltage supply
4	In 2	Input OSSD 2
5	Magnet	Magnet control 24 V DC output

For details see operating instructions

## Pinouts

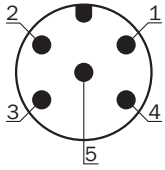

Pin	Designation	Description
1	In 24 V DC	Safety switch voltage supply
2	OSSD 1	OSSD 1 output
3	0 V	0 V DC voltage supply
4	OSSD 2	OSSD 2 output
5	Magnet	Magnet control 24 V DC input
For details see operating instructions		

## SICK AT A GLANCE

SICK is one of the leading manufacturers of intelligent sensors and sensor solutions for industrial applications. A unique range of products and services creates the perfect basis for controlling processes securely and efficiently, protecting individuals from accidents and preventing damage to the environment.

We have extensive experience in a wide range of industries and understand their processes and requirements. With intelligent sensors, we can deliver exactly what our customers need. In application centers in Europe, Asia and North America, system solutions are tested and optimized in accordance with customer specifications. All this makes us a reliable supplier and development partner.

Comprehensive services complete our offering: SICK LifeTime Services provide support throughout the machine life cycle and ensure safety and productivity.

For us, that is “Sensor Intelligence.”

## WORLDWIDE PRESENCE:

Contacts and other locations –[www.sick.com](http://www.sick.com)