

SICK

AFM60B-TGRK000S14

AFS/AFM60 SSI

ABSOLUTE ENCODERS

SICK
Sensor Intelligence.



Ordering information

| Type | part no. |
|-------------------|----------|
| AFM60B-TGRK000S14 | 1077724 |

Illustration may differ

Other models and accessories → www.sick.com/AFS_AFM60_SSI



Detailed technical data

Features

| | |
|----------------------------------|---|
| Special device | ✓ |
| Specialty | Customized stator coupling 2047430 Cable, 12-wire, radial 0.857 m with M23 male connector on cable end HTL preprogrammed Preprogrammed number of SSI steps: 8,192 Preprogrammed preset position: 16,777,215 |
| Standard reference device | AFM60B-TGRK032768, 8012885 |

Safety-related parameters

| | |
|--|--|
| MTTF_D (mean time to dangerous failure) | 250 years (EN ISO 13849-1) ¹⁾ |
|--|--|

¹⁾ This product is a standard product and does not constitute a safety component as defined in the Machinery Directive. Calculation based on nominal load of components, average ambient temperature 40 °C, frequency of use 8760 h/a. All electronic failures are considered hazardous. For more information, see document no. 8015532.

Performance

| | |
|---|----------------------------------|
| Number of steps per revolution (max. resolution) | 32,768 (15 bit) |
| Number of revolutions | 4,096 (12 bit) |
| Max. resolution (number of steps per revolution x number of revolutions) | 15 bit x 12 bit (32,768 x 4,096) |
| Error limits G | 0.05° ¹⁾ |
| Repeatability standard deviation σ_r | 0.002° ²⁾ |

¹⁾ In accordance with DIN ISO 1319-1, position of the upper and lower error limit depends on the installation situation, specified value refers to a symmetrical position, i.e. deviation in upper and lower direction is the same.

²⁾ In accordance with DIN ISO 55350-13; 68.3% of the measured values are inside the specified area.

Interfaces

| | |
|---------------------------------------|---------------------|
| Communication interface | SSI |
| Communication Interface detail | SSI + incremental |
| Initialization time | 50 ms ¹⁾ |
| Position forming time | < 1 μs |
| Code type | Gray |

¹⁾ Valid positional data can be read once this time has elapsed.

²⁾ Minimum, LOW level (Clock +): 250 ns.

| | |
|--|---|
| Code sequence parameter adjustable | CW/CCW (V/R) parameter adjustable |
| Clock frequency | $\leq 2 \text{ MHz}^{2)}$ |
| Set (electronic adjustment) | H-active (L = 0 - 3 V, H = 4,0 - U_s V) |
| CW/CCW (counting sequence when turning) | L-active (L = 0 - 1,5 V, H = 2,0 - U_s V) |
| Pulses per revolution | 1/4 of number of SSI steps per revolution |
| Output frequency | $\leq 600 \text{ kHz}$ |
| Load current | $\leq 30 \text{ mA}$ |

¹⁾ Valid positional data can be read once this time has elapsed.

²⁾ Minimum, LOW level (Clock +): 250 ns.

Electronics

| | |
|------------------------------------|---|
| Connection type | Special version |
| Connection type Detail | Cable, 12-wire, radial, 0.857 m, with M23 12-pin male connector |
| Supply voltage | 4.5 ... 32 V DC |
| Power consumption | $\leq 0.7 \text{ W}$ (without load) |
| Reverse polarity protection | ✓ |

Mechanics

| | |
|---------------------------------------|---|
| Mechanical design | Through hollow shaft |
| Shaft diameter | 14 mm |
| Characteristics of the shaft | Front clamp |
| Weight | 0.2 kg ¹⁾ |
| Shaft material | Stainless steel |
| Flange material | Aluminum |
| Housing material | Aluminum die cast |
| Start up torque | $< 0.8 \text{ Ncm}$ (+20 °C) |
| Operating torque | $< 0.6 \text{ Ncm}$ (+20 °C) |
| Permissible movement static | $\pm 0.3 \text{ mm}$ (radial) $\pm 0.5 \text{ mm}$ (axial) |
| Permissible movement dynamic | $\pm 0.1 \text{ mm}$ (radial) $\pm 0.2 \text{ mm}$ (axial) |
| Operating speed | $\leq 9,000 \text{ min}^{-1}$ ²⁾ |
| Moment of inertia of the rotor | 40 gcm ² |
| Bearing lifetime | 3.0×10^9 revolutions |
| Angular acceleration | $\leq 500,000 \text{ rad/s}^2$ |

¹⁾ Based on devices with male connector.

²⁾ Allow for self-heating of 3.3 K per 1,000 rpm when designing the operating temperature range.

Ambient data

| | |
|-------------------------|--|
| EMC | According to EN 61000-6-2 and EN 61000-6-3 ¹⁾ |
| Enclosure rating | IP65, shaft side (IEC 60529) |

¹⁾ EMC according to the standards quoted is achieved if shielded cables are used.

²⁾ For devices with male connector: with mounted mating connector.

³⁾ Stationary position of the cable.

| | |
|--------------------------------------|--|
| | IP67, housing side (IEC 60529) ²⁾ |
| Permissible relative humidity | 90 % (Condensation not permitted) |
| Operating temperature range | -40 °C ... +100 °C ³⁾ |
| Storage temperature range | -40 °C ... +100 °C, without package |
| Resistance to shocks | 70 g, 6 ms (EN 60068-2-27) |
| Resistance to vibration | 30 g, 10 Hz ... 2,000 Hz (EN 60068-2-6) |

¹⁾ EMC according to the standards quoted is achieved if shielded cables are used.

²⁾ For devices with male connector: with mounted mating connector.

³⁾ Stationary position of the cable.

Certificates

| | |
|--|---|
| EU declaration of conformity | ✓ |
| UK declaration of conformity | ✓ |
| ACMA declaration of conformity | ✓ |
| Moroccan declaration of conformity | ✓ |
| China RoHS | ✓ |
| cULus certificate | ✓ |
| Information according to Art. 3 of Data Act (Regulation EU 2023/2854) | ✓ |

Classifications

| | |
|-----------------------|----------|
| ECLASS 5.0 | 27270502 |
| ECLASS 5.1.4 | 27270502 |
| ECLASS 6.0 | 27270590 |
| ECLASS 6.2 | 27270590 |
| ECLASS 7.0 | 27270502 |
| ECLASS 8.0 | 27270502 |
| ECLASS 8.1 | 27270502 |
| ECLASS 9.0 | 27270502 |
| ECLASS 10.0 | 27270502 |
| ECLASS 11.0 | 27270502 |
| ECLASS 12.0 | 27270502 |
| ETIM 5.0 | EC001486 |
| ETIM 6.0 | EC001486 |
| ETIM 7.0 | EC001486 |
| ETIM 8.0 | EC001486 |
| UNSPSC 16.0901 | 41112113 |

Dimensional drawing

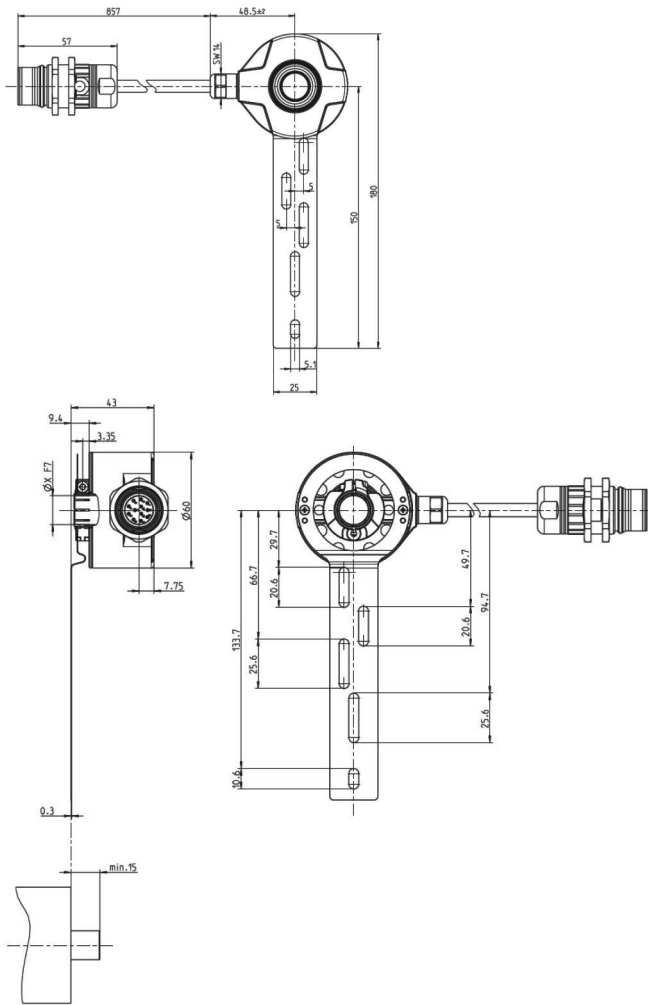

Dimensions in mm (inch)

Anschlussbelegung

| Pin | Signal | Explanation |
|-----|---------------------|--|
| 1 | +U _s | Supply voltage |
| 2 | GND | Ground connection |
| 3 | Clock+ | Interface signal |
| 4 | Data+ | Interface signal |
| 5 | SET | Electronic adjustment |
| 6 | Data- | Interface signal |
| 7 | Clock- | Interface signal |
| 8 | \bar{B} | Signal line |
| 9 | $\overline{CW/CCW}$ | Counting sequence when turning |
| 10 | \bar{A} | Signal line |
| 11 | A | Signal line |
| 12 | B | Signal line |
| | Screen | Screen on the encoder side connected to the housing. On the control side connected to earth. |

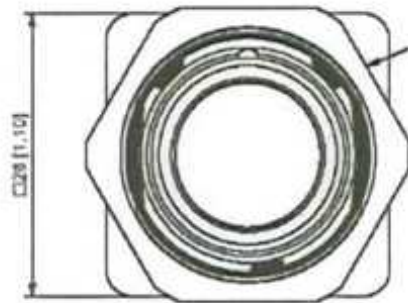
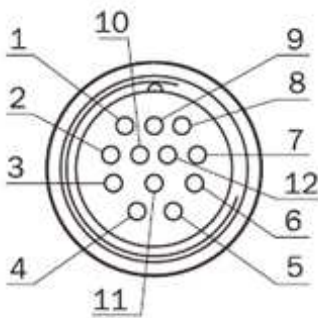

Diagrams

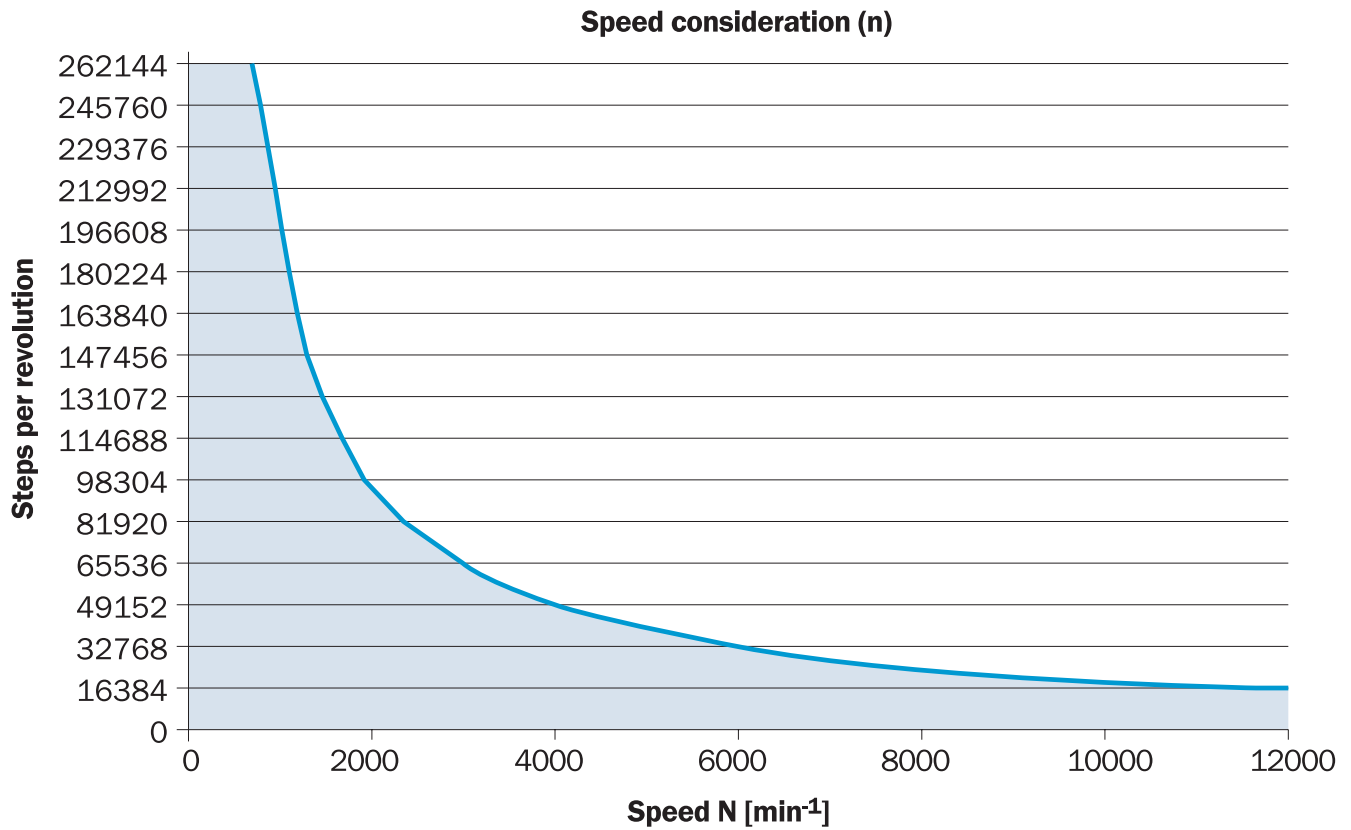

The maximum speed is also dependent on the shaft type.

SICK AT A GLANCE

SICK is one of the leading manufacturers of intelligent sensors and sensor solutions for industrial applications. A unique range of products and services creates the perfect basis for controlling processes securely and efficiently, protecting individuals from accidents and preventing damage to the environment.

We have extensive experience in a wide range of industries and understand their processes and requirements. With intelligent sensors, we can deliver exactly what our customers need. In application centers in Europe, Asia and North America, system solutions are tested and optimized in accordance with customer specifications. All this makes us a reliable supplier and development partner.

Comprehensive services complete our offering: SICK LifeTime Services provide support throughout the machine life cycle and ensure safety and productivity.

For us, that is “Sensor Intelligence.”

WORLDWIDE PRESENCE:

Contacts and other locations –www.sick.com