



# STR1-SAFU0AC5

## STR1

NON-CONTACT SAFETY SWITCHES

**SICK**  
Sensor Intelligence.



Illustration may differ



## Ordering information

| Type          | part no. |
|---------------|----------|
| STR1-SAFU0AC5 | 1069575  |

Other models and accessories → [www.sick.com/STR1](http://www.sick.com/STR1)

## Detailed technical data

### Features

|  |  |
|--|--|
| <b>System part</b>                                     | Sensor with actuator   |
| <b>Sensor principle</b>                                | RFID   |
| <b>Number of safe outputs</b>                          | 2  |
| <b>Auxiliary contact (AUX)</b>                         | 1 (Switching behavior complementary to OSSDs)                                |
| <b>Assured switch on distance <math>S_{ao}</math></b>  | 14 mm (-10 ... +70 °C) <sup>1)</sup><br>10 mm (-30 ... -10 °C) <sup>1)</sup> |
| <b>Assured switch off distance <math>S_{ar}</math></b> | 28 mm <sup>1)</sup>  |
| <b>Active sensor surfaces</b>                          | 3  |
| <b>Active sensor surface</b>                           | Top, sides (left, right) <sup>2)</sup>                                       |
| <b>Actuation directions</b>                            | 5  |
| <b>Coding</b>  | Uniquely coded   |

<sup>1)</sup> Values apply for the frontal alignment of the sensor to the actuator. A detailed display of the alignment options and values can be found in the operating instructions.

<sup>2)</sup> For details see operating instructions.

### Safety-related parameters

|   |  |
|---|--|
| <b>Safety integrity level</b>   | SIL 3 (IEC 61508)  |
| <b>Category</b>   | Category 4 (EN ISO 13849)  |
| <b>Performance level</b>  | PL e (EN ISO 13849)  |
| <b>PFH<sub>D</sub> (mean probability of a dangerous failure per hour)</b> | $5,1 \times 10^{-9}$   |
| <b>T<sub>M</sub> (mission time)</b>                                       | 20 years (EN ISO 13849)  |
| <b>Type</b>   | Type 4 (EN ISO 14119)  |
| <b>Actuator coding level</b>  | High coding level (EN ISO 14119)   |
| <b>Safe state in the event of a fault</b>                                 | At least one safety-related semiconductor output (OSSD) is in the OFF state. |

### Functions

|                               |                                    |
|-------------------------------|------------------------------------|
| <b>Safe series connection</b> | With Flexi Loop (with diagnostics) |
|-------------------------------|------------------------------------|

### Interfaces

|                        |                            |
|------------------------|----------------------------|
| <b>Connection type</b> | Cable with plug M12, 5-pin |
| Length of cable        | 0.2 m                      |

|                                       |                              |
|---------------------------------------|------------------------------|
| Long connecting cable                 | ≤ 200 m                      |
| Cable diameter                        | 5.5 mm                       |
| Conductor cross section               | 0.12 mm <sup>2</sup>         |
| Bend radius (with fixed installation) | > 8 x cable diameter         |
| Bend radius (with moving cable)       | > 12 x cable diameter        |
| Cable material                        | PVC                          |
| Conductor material                    | Copper                       |
| Coupling nut material                 | Zinc die-cast, nickel-plated |
| <b>Display elements</b>               | LEDs                         |
| Diagnostics indicator                 | ✓                            |
| Status display                        | ✓                            |

## Electronics

|  |   |
|--|---|
| <b>Protection class</b>                  | III (IEC 61140)                               |
| <b>Classification according to cULus</b> | Class 2                                       |
| <b>Supply voltage V<sub>s</sub></b>      | 24 V DC (19.2 V DC ... 28.8 V DC)             |
| <b>Power consumption</b>                 | 50 mA   |
| <b>Type of output</b>                    | Self-monitoring semiconductor outputs (OSSDs) |
| <b>Output current</b>                    | ≤ 100 mA                                      |
| <b>Response time</b>                     | 40 ms <sup>1)</sup>                           |
| <b>Release time</b>                      | 100 ms <sup>1) 2)</sup>                       |
| <b>Risk time</b>                         | 80 ms <sup>1) 3)</sup>                        |
| <b>Switch-on time</b>                    | 2.5 s <sup>4)</sup>                           |

<sup>1)</sup> In a safe series connection, each downstream safety switch increases the system response time. More response times can be found in the operating instructions.

<sup>2)</sup> Response time on approach to the enable zone.

<sup>3)</sup> Detection time for internal oder external faults (e.g., short-circuit or cross-circuit of output signal switching devices). Follow the detailed information in the operating instructions.

<sup>4)</sup> The time specified applies to one sensor after the supply voltage has been applied to the safety switch. In a safe series connection, 0.1-s must be added for each sensor. An additional 0.5-s per taught-in actuator must be added for uniquely coded and permanently coded sensors.

## Mechanics

|                               |                       |
|-------------------------------|-----------------------|
| <b>Dimensions (W x H x D)</b> | 40 mm x 18 mm x 26 mm |
| <b>Weight</b>                 | 68 g                  |
| <b>Housing material</b>       | VISTAL®               |

## Ambient data

|                                      |  |
|--------------------------------------|--|
| <b>Enclosure rating</b>              | IP67, IP69K (EN 60529, ISO 20653)                        |
| <b>Ambient operating temperature</b> | -30 °C ... +70 °C <sup>1)</sup>                          |
| <b>Storage temperature</b>           | -30 °C ... +70 °C  |
| <b>Vibration resistance</b>          | 10 Hz ... 55 Hz, 1 mm (IEC 60068-2-6)                    |
| <b>Shock resistance</b>              | 30 g, 11 ms (IEC 60068-2-27)                             |
| <b>EMC</b>                           | EN IEC 61326-3-1<br>EN IEC 60947-5-2<br>EN IEC 60947-5-3 |

<sup>1)</sup> Only applies for safety switches whose serial numbers begin with number series 1825\*\*\*\* or higher. For safety switches whose serial numbers deviate from this, an ambient operating temperature of -10 °C ... +70 °C applies. The serial number is displayed on the safety switch over the data matrix code.

EN 300330 V2.1.1

<sup>1)</sup> Only applies for safety switches whose serial numbers begin with number series 1825\*\*\*\* or higher. For safety switches whose serial numbers deviate from this, an ambient operating temperature of -10 °C ... +70 °C applies.  
The serial number is displayed on the safety switch over the data matrix code.

### Certificates

|                                       |   |
|---------------------------------------|---|
| <b>EU declaration of conformity</b>   | ✓ |
| <b>UK declaration of conformity</b>   | ✓ |
| <b>ACMA declaration of conformity</b> | ✓ |
| <b>China RoHS</b>                     | ✓ |
| <b>TÜV approval</b>                   | ✓ |
| <b>TÜV approval annex</b>             | ✓ |
| <b>EC-Type-Examination approval</b>   | ✓ |

### Classifications

|                       |          |
|-----------------------|----------|
| <b>ECLASS 5.0</b>     | 27272403 |
| <b>ECLASS 5.1.4</b>   | 27272403 |
| <b>ECLASS 6.0</b>     | 27272403 |
| <b>ECLASS 6.2</b>     | 27272403 |
| <b>ECLASS 7.0</b>     | 27272403 |
| <b>ECLASS 8.0</b>     | 27272403 |
| <b>ECLASS 8.1</b>     | 27272403 |
| <b>ECLASS 9.0</b>     | 27272403 |
| <b>ECLASS 10.0</b>    | 27272403 |
| <b>ECLASS 11.0</b>    | 27272403 |
| <b>ECLASS 12.0</b>    | 27274601 |
| <b>ETIM 5.0</b>       | EC001829 |
| <b>ETIM 6.0</b>       | EC001829 |
| <b>ETIM 7.0</b>       | EC001829 |
| <b>ETIM 8.0</b>       | EC001829 |
| <b>UNSPSC 16.0901</b> | 39122205 |

Dimensional drawing “Flat” actuator

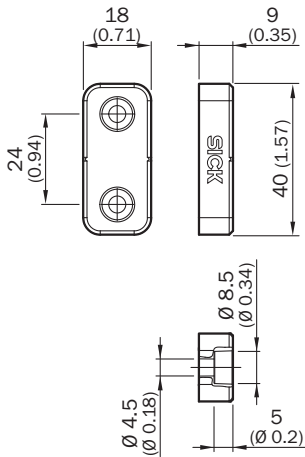

Dimensions in mm (inch)

Dimensional drawing Sensor with cable and male connector

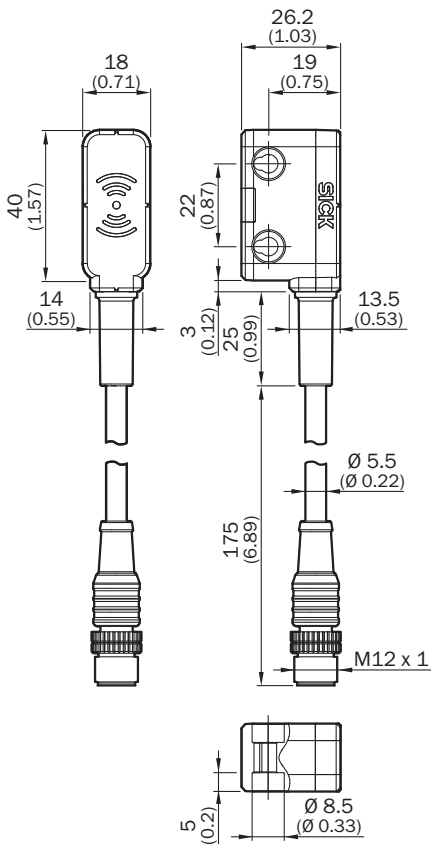

Dimensions in mm (inch)

Response range "Flat"/"Mini" actuator, active side sensor surface



Assured switch on distance Sao 9 mm. Observe border areas for parallel approach: a minimum distance of 4 mm (typical) must be upheld when the actuator moves laterally to the sensor surface. This prevents early triggering due to the side preparation areas.

Response range "Flat"/"Mini" actuator, active front sensor surface



Assured switch on distance Sao 14 mm. Observe border areas for parallel approach: a minimum distance of 10 mm (typical) must be upheld when the actuator moves laterally to the sensor surface. This prevents early triggering due to the side preparation areas.

## Pinouts

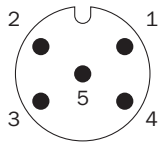

|   |                        |
|---|------------------------|
| 1 | Voltage supply 24 V DC |
| 2 | OSSD 1                 |
| 3 | Voltage supply 0 V DC  |
| 4 | OSSD 2                 |
| 5 | Aux output (not safe)  |

## Connection single sensor

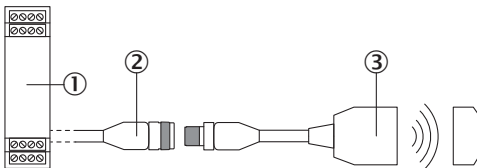

- ① Safe evaluation unit
- ② connecting cable with M12 female connector, 5-pin and flying leads (e.g., YF2A15-xxxVB5XLEAX)
- ③ STR1 RFID safety switch (e.g., STR1-SAx0AC5)

## Series connection with Flexi Loop (with diagnostics)

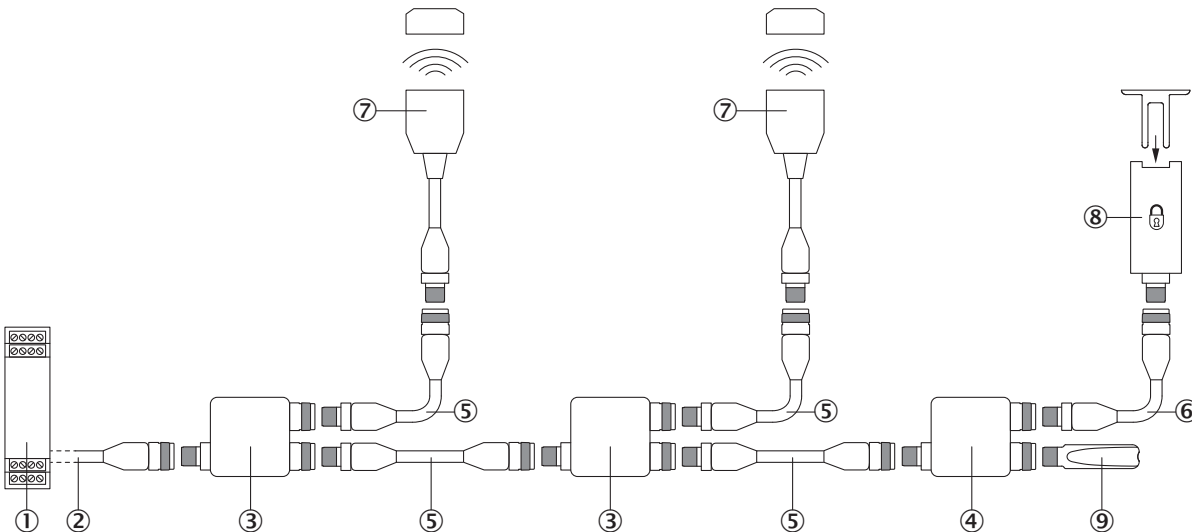

- ① Flexi Soft safety controller
- ② connecting cable with M12 female connector, 5-pin and flying leads (e.g., YF2A15-xxxVB5XLEAX)
- ③ FLN-OSSD1000105 Flexi Loop node
- ④ FLN-EMSS1100108 Flexi Loop node
- ⑤ Connection cable with 5-pin, M12 male connector and 5-pin, M12 female connector (e.g., YF2A15-xxxUB5M2A15)
- ⑥ Connection cable with 8-pin, M12 male connector and 8-pin, M12 female connector (e.g., YF2A18-xxxUA5M2A18)
- ⑦ STR1 RFID safety switch (e.g., STR1-SAx0AC5)

- Ⓢ Safety locking device (e.g., i10-x0454 or i110-x0454)
- Ⓢ FLT-TERM00001 Flexi Loop terminating element

Connection diagram STR1 RFID safety switch to RLY3-OSSD2 safety relay

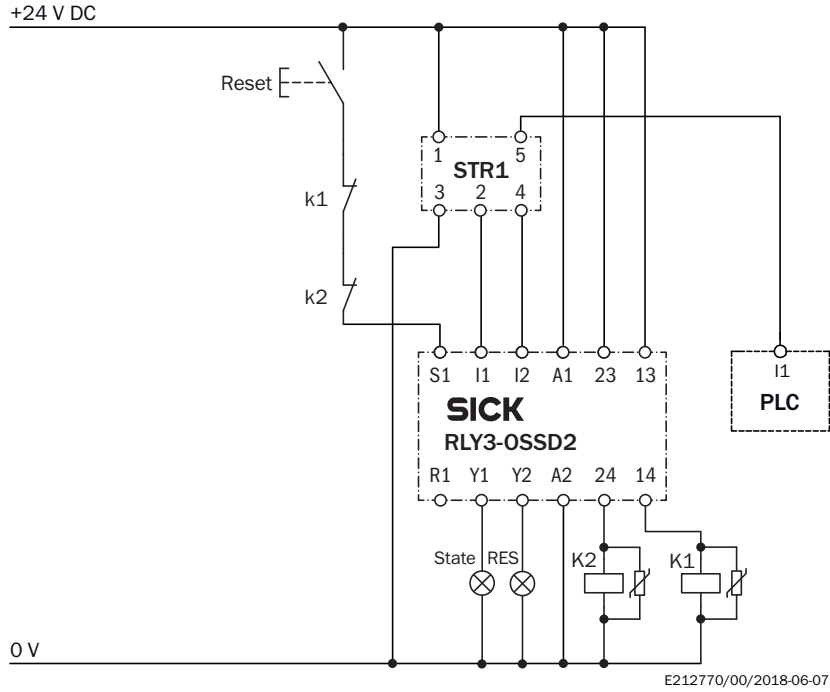

Connection diagram Parallel connection of two STR1 RFID safety switches to a Flexi Classic safety controller

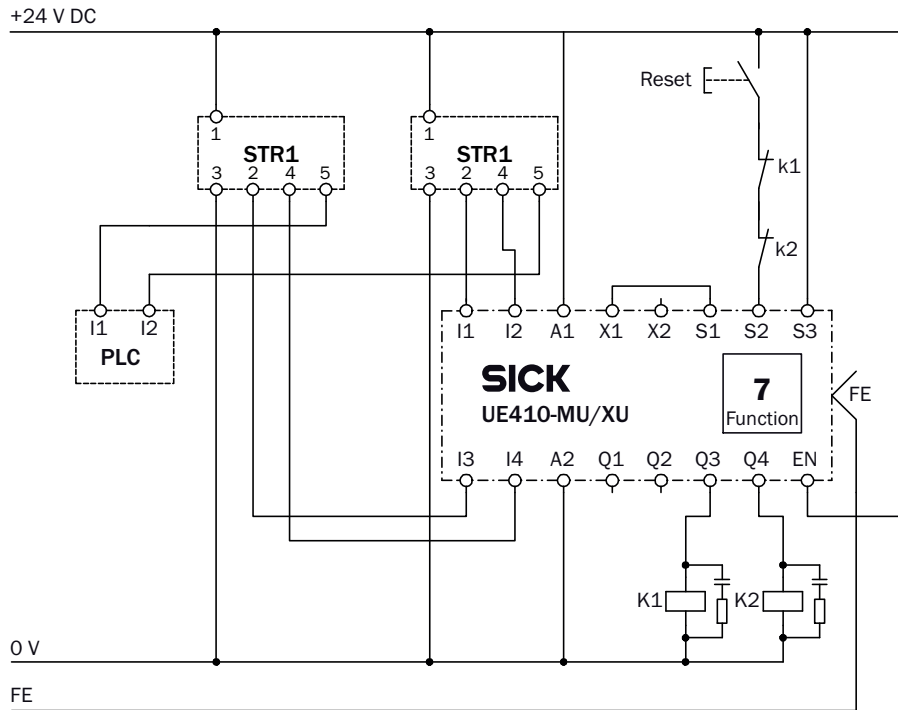

E148463/00/2016-02-08

Recommended accessories

Other models and accessories → [www.sick.com/STR1](http://www.sick.com/STR1)

|   | Brief description   | Type                     | part no. |
|---|---|--------------------------|----------|
| connectors and cables   |   |                          |          |
|    | <ul style="list-style-type: none"> <li><b>Description:</b> Sensor/actuator cable, unshielded</li> <li><b>Connection type head A:</b> Female connector, M12, 5-pin, straight, A-coded</li> <li><b>Connection type head B:</b> Flying leads</li> <li><b>Signal type:</b> Sensor/actuator cable</li> <li><b>Cable:</b> 2 m, 5-wire, PVC</li> <li><b>Application:</b> Untaminated zones, Zones with chemicals</li> </ul>  | YF2A15-020VB5XLEAX       | 2096239  |
|    | <ul style="list-style-type: none"> <li><b>Description:</b> Sensor/actuator cable, unshielded</li> <li><b>Connection type head A:</b> Female connector, M12, 5-pin, straight, A-coded</li> <li><b>Connection type head B:</b> Flying leads</li> <li><b>Signal type:</b> Sensor/actuator cable</li> <li><b>Cable:</b> 5 m, 5-wire, PVC</li> <li><b>Application:</b> Untaminated zones, Zones with chemicals</li> </ul>  | YF2A15-050VB5XLEAX       | 2096240  |
|    | <ul style="list-style-type: none"> <li><b>Description:</b> Sensor/actuator cable, unshielded</li> <li><b>Connection type head A:</b> Female connector, M12, 5-pin, straight, A-coded</li> <li><b>Connection type head B:</b> Flying leads</li> <li><b>Signal type:</b> Sensor/actuator cable</li> <li><b>Cable:</b> 10 m, 5-wire, PVC</li> <li><b>Application:</b> Untaminated zones, Zones with chemicals</li> </ul>   | YF2A15-100VB5XLEAX       | 2096241  |
|    | <ul style="list-style-type: none"> <li><b>Description:</b> Sensor/actuator cable, unshielded</li> <li><b>Connection type head A:</b> Female connector, M12, 5-pin, straight, A-coded</li> <li><b>Connection type head B:</b> Flying leads</li> <li><b>Signal type:</b> Sensor/actuator cable</li> <li><b>Cable:</b> 0.6 m, 5-wire, PVC</li> <li><b>Application:</b> Untaminated zones, Zones with chemicals</li> </ul>  | YF2A15-C60VB5XLEAX       | 2145570  |
|   | <ul style="list-style-type: none"> <li><b>Description:</b> Sensor/actuator cable, unshielded</li> <li><b>Connection type head A:</b> Female connector, M12, 5-pin, straight, A-coded</li> <li><b>Connection type head B:</b> Flying leads</li> <li><b>Signal type:</b> Sensor/actuator cable</li> <li><b>Cable:</b> 3 m, 5-wire, PVC</li> <li><b>Application:</b> Untaminated zones, Zones with chemicals</li> </ul>  | YF2A15-030VB5XLEAX       | 2145572  |
| Safety relays   |   |                          |          |
|  | <ul style="list-style-type: none"> <li><b>Applications:</b> Evaluation unit</li> <li><b>Compatible sensor types:</b> Safety sensors with OSSDs</li> <li><b>Connection type:</b> Front connector with spring terminals</li> <li><b>Restart interlock:</b> yes</li> <li><b>External device monitoring (EDM):</b> Integrated</li> <li><b>Outputs:</b> 2 enabling current paths (safe), 2 application diagnostic outputs (not safe), 1 test pulse output (not safe)</li> <li><b>Housing width:</b> 18 mm</li> </ul> | RLY3-OSSD200             | 1085344  |
| Mounting systems  |   |                          |          |
|  | <ul style="list-style-type: none"> <li><b>Packing unit:</b> 10 pieces</li> </ul>  | Safety screws<br>M4 x 14 | 5333570  |

## SICK AT A GLANCE

SICK is one of the leading manufacturers of intelligent sensors and sensor solutions for industrial applications. A unique range of products and services creates the perfect basis for controlling processes securely and efficiently, protecting individuals from accidents and preventing damage to the environment.

We have extensive experience in a wide range of industries and understand their processes and requirements. With intelligent sensors, we can deliver exactly what our customers need. In application centers in Europe, Asia and North America, system solutions are tested and optimized in accordance with customer specifications. All this makes us a reliable supplier and development partner.

Comprehensive services complete our offering: SICK LifeTime Services provide support throughout the machine life cycle and ensure safety and productivity.

For us, that is “Sensor Intelligence.”

## WORLDWIDE PRESENCE:

Contacts and other locations –[www.sick.com](http://www.sick.com)