



ISD400-7212

ISD400

OPTICAL DATA TRANSMISSION

SICK
Sensor Intelligence.



Ordering information

Type	part no.
ISD400-7212	1065101

Other models and accessories → www.sick.com/ISD400

Illustration may differ



Detailed technical data

Features

Product segment	Optical data transmission
Product	ISD400
Product version	ISD400 Pro
Housing material	AlSi12
Enclosure rating	IP65
Light source	Laser, red, 660 nm
Power consumption	1)
Ambient operating temperature	-20 °C ... +55 °C
Relative humidity	90 %, Non-condensing
Weight	Approx. 800 g

1) Without load with 24 V.

Mechanics/electronics

Supply voltage V_s	DC 18 V ... 30 V
Power consumption	$\leq 3.6 \text{ W}^{1)}$
Connection type	1 x Ethernet female connector M12, 4-pin, D-coded 1 x power supply male connector M12, 4-pin, A-coded
Frequency	F2
Enclosure rating	IP65
Protection class	III

1) Without load with 24 V.

Performance

Transmission range	$\geq 0.2 \text{ m}$
Light source	Laser, red (660 nm)
Laser class	1M (IEC 60825-1:2014, EN 60825-1:2014) ¹⁾

1) Do not intentionally look into the laser beam. Never point the laser beam at people's eyes.

2) CAUTION: Never look directly at the laser beam using optical instruments. Optical instruments include magnifying glasses, microscopes, telescopes and binoculars.

	2)
Typ. light spot size (distance)	1.75 m (at 100 m)
Aperture angle	Sender

¹⁾ Do not intentionally look into the laser beam. Never point the laser beam at people's eyes.

²⁾ CAUTION: Never look directly at the laser beam using optical instruments. Optical instruments include magnifying glasses, microscopes, telescopes and binoculars.

Interfaces

Ethernet		✓
	Data transmission rate	100 Mbit/s
Digital input		V _S : sender deactivated
Digital output		
	Number	1 ¹⁾
	Type	PNP
	Function	Output active for LOW and HIGH level
		Warning messages as the laser ages, if the permissible limits of the interior device temperature are exceeded or undercut, if the optical path is interrupted, if no Ethernet cable is connected, if the receiving level is undercut, if the laser is not ready for operation, if the heating is switched on.

¹⁾ HIGH: U_V - 3 V, LOW: < 2 V.

Ambient data

Electromagnetic compatibility (EMC)	EN 61000-6-2 ¹⁾ EN 61000-6-4
Ambient temperature, operation	-20 °C ... +55 °C
Max. rel. humidity (not condensing)	90 %, Non-condensing

¹⁾ This is a Class A device. This device can cause radio interference in living quarters.

General notes

Note	Setting up a data transmission path requires a pair of devices, where one device has frequency F1 (ISD400-7xx1) and the other device has frequency F2 (ISD400-7xx2). A wide variety of Ethernet protocols can be used in protocol-free transmission (e.g., PROFINET, PROFI-safe, EtherNet/IP, EtherCAT, TCP/IP, etc.).
-------------	--

Classifications

ECLASS 5.0	19039001
ECLASS 5.1.4	19039001
ECLASS 6.0	19179090
ECLASS 6.2	19179090
ECLASS 7.0	19179090
ECLASS 8.0	19179090
ECLASS 8.1	19179090
ECLASS 9.0	19179090
ETIM 5.0	EC000515
ETIM 6.0	EC000515
UNSPSC 16.0901	43201404

Certificates

EU declaration of conformity	✓
-------------------------------------	---

UK declaration of conformity	✓
ACMA declaration of conformity	✓
Moroccan declaration of conformity	✓
China RoHS	✓
cULus certificate	✓

Dimensional drawing

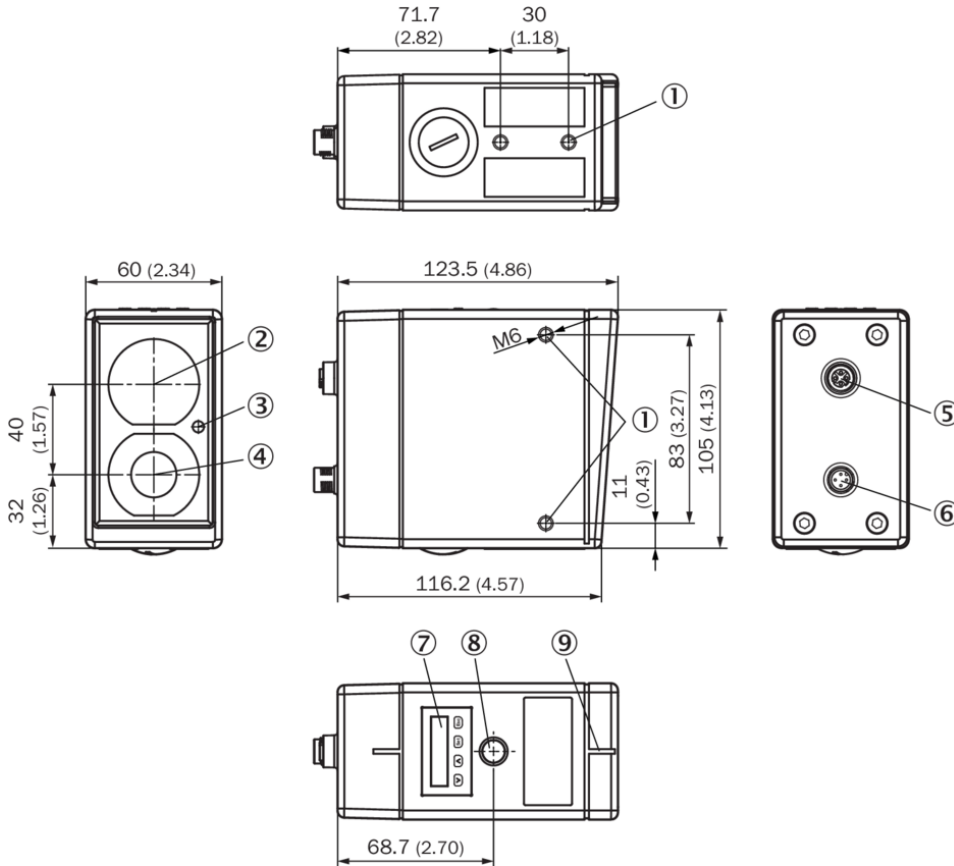

Dimensions in mm (inch)

- ① Threaded mounting hole M6
- ② Center of optical axis, sender
- ③ Receive indicator
- ④ Center of optical axis, receiver
- ⑤ Ethernet female connector M12, 4-pin, D-coded
- ⑥ Power supply male connector M12, 4-pin, A-coded
- ⑦ Display with pushbuttons
- ⑧ Optical adjustment aid
- ⑨ Alignment sight

Dimensional drawing

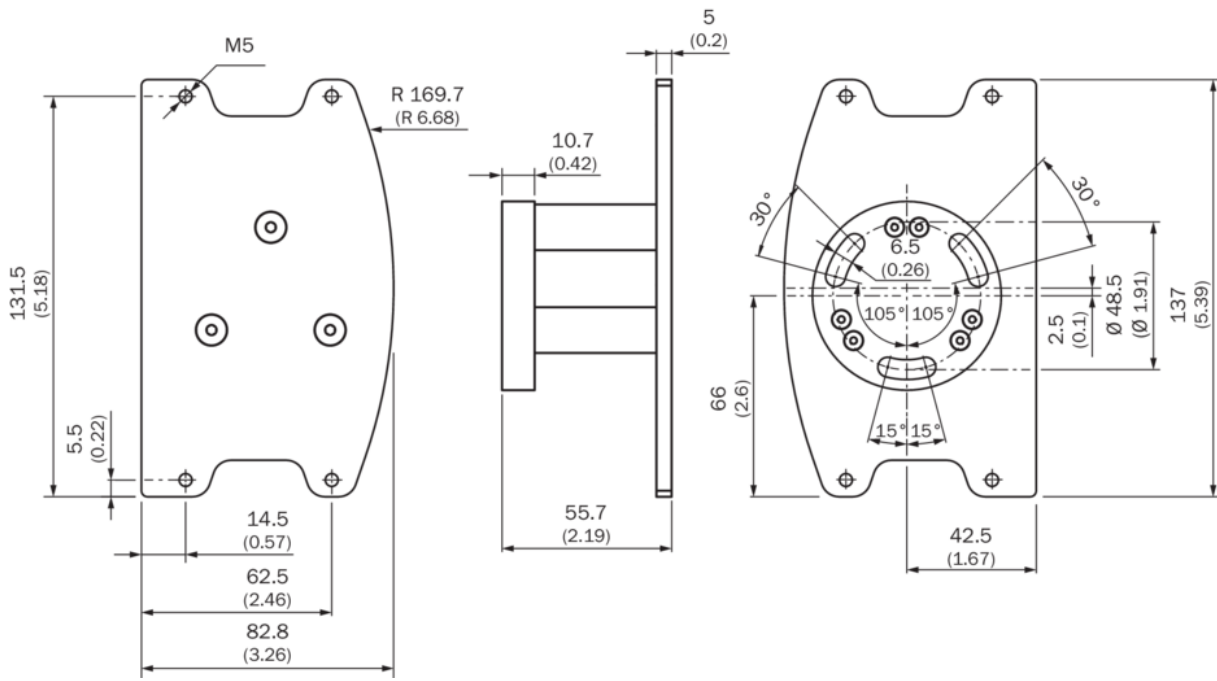

Dimensions in mm (inch)

Dimensional drawing

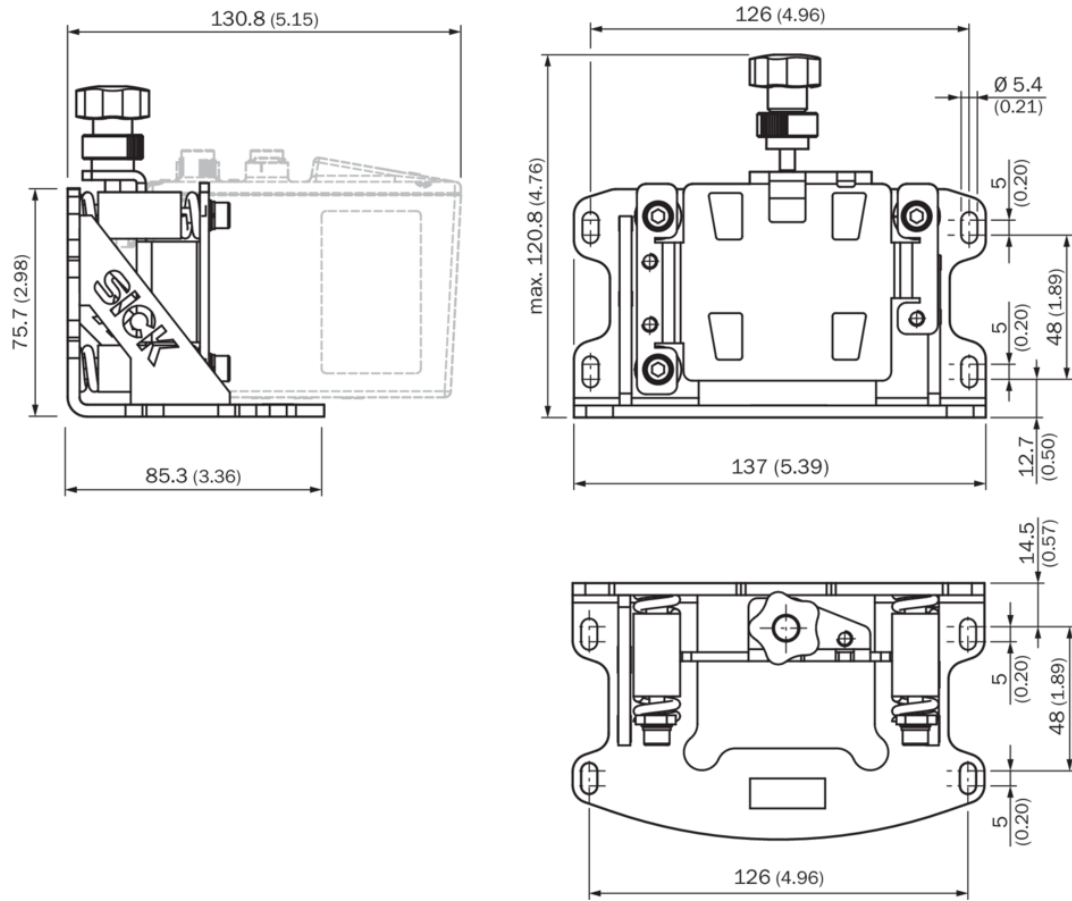

Dimensions in mm (inch)

Dimensional drawing

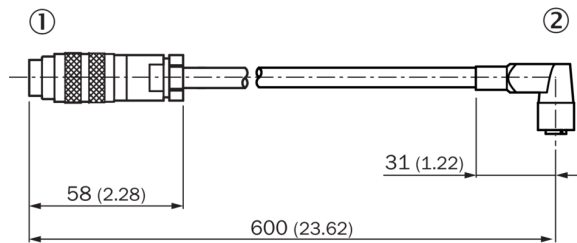

Dimensions in mm (inch)

- ① Connector M16, 8-pin
- ② male connector M12, 8-pin

Voltage supply connection type

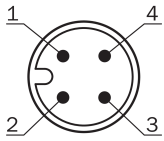

Ethernet connection type

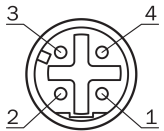

Voltage supply connection diagram

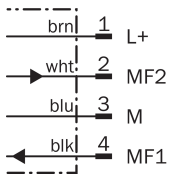

Ethernet connection diagram

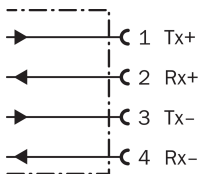

Adjustments

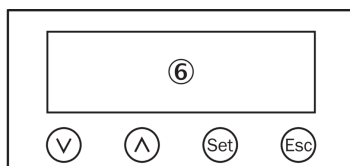

⑥ Liquid crystal display with function keys

SICK AT A GLANCE

SICK is one of the leading manufacturers of intelligent sensors and sensor solutions for industrial applications. A unique range of products and services creates the perfect basis for controlling processes securely and efficiently, protecting individuals from accidents and preventing damage to the environment.

We have extensive experience in a wide range of industries and understand their processes and requirements. With intelligent sensors, we can deliver exactly what our customers need. In application centers in Europe, Asia and North America, system solutions are tested and optimized in accordance with customer specifications. All this makes us a reliable supplier and development partner.

Comprehensive services complete our offering: SICK LifeTime Services provide support throughout the machine life cycle and ensure safety and productivity.

For us, that is “Sensor Intelligence.”

WORLDWIDE PRESENCE:

Contacts and other locations –www.sick.com