

SRM50S-HGV0-K22

SRS/SRM50-S

SAFE MOTOR FEEDBACK SYSTEMS

SICK
Sensor Intelligence.

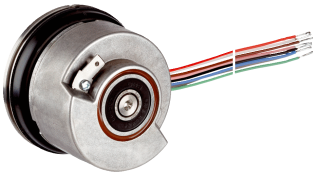

Illustration may differ



Ordering information

| Type | part no. |
|-----------------|----------|
| SRM50S-HGV0-K22 | 1051804 |

Other models and accessories → www.sick.com/SRS_SRM50-S

Detailed technical data

Features

| | |
|-----------------------|---|
| Items supplied | Mounting screws for stator coupling or servo clamps not included with delivery. |
|-----------------------|---|

Safety-related parameters

| | |
|---|---------------------------------------|
| Safety integrity level | SIL 2 (IEC 61508), SILCL2 (IEC 62061) |
| Category | 3 (EN ISO 13849) |
| Maximum demand rate | Continuous (analog signals) |
| Performance level | PL d (EN ISO 13849) ¹⁾ |
| PFH (mean probability of a dangerous failure per hour) | 1.0×10^{-8} ²⁾ |
| T_M (mission time) | 20 years (EN ISO 13849) |
| MTTF_D (mean time to dangerous failure) | 1,073 years (EN ISO 13849) |

¹⁾ For more detailed information on the exact configuration of your machine/unit, please consult your relevant SICK branch office.

²⁾ The values displayed apply to a diagnostic degree of coverage of 90%, which must be achieved by the external drive system.

Performance

| | |
|---|--|
| Sine/cosine periods per revolution | 1,024 |
| Number of the absolute ascertainable revolutions | 4,096 |
| Total number of steps | 134,217,728 |
| Measuring step | 0.3 " For interpolation of the sine/cosine signals with, e. g., 12 bits |
| Integral non-linearity | Typ. ± 45 ", Error limits for evaluating sine/cosine period, without mechanical tension of the stator coupling |
| Differential non-linearity | ± 7 " |
| Operating speed | $\leq 6,000 \text{ min}^{-1}$, up to which the absolute position can be reliably produced |
| Available memory area | 1,792 Byte |
| System accuracy | ± 52 " |

Interfaces

| | |
|--|---|
| Type of code for the absolute value | Binary |
| Code sequence | Increasing, when turning the shaft For clockwise rotation, looking in direction "A" (see dimensional drawing), For clockwise shaft rotation, looking in direction "A" (see dimensional drawing) |
| Communication interface | HIPERFACE® |

Electronics

| | |
|---|----------------------------|
| Connection type | Cable, 8-wire, radial, 2 m |
| Supply voltage | 7 V DC ... 12 V DC |
| Recommended supply voltage | 8 V DC |
| Current consumption | 80 mA ¹⁾ |
| Output frequency for sine/cosine signals | ≤ 200 kHz |

¹⁾ Without load.

Mechanics

| | |
|---|--------------------------------------|
| Shaft version | Tapered shaft |
| Flange type / stator coupling | Resolver support, Resolver support |
| Dimensions | See dimensional drawing |
| Weight | ≤ 0.2 kg |
| Moment of inertia of the rotor | 10 gcm ² |
| Operating speed | ≤ 12,000 min ⁻¹ |
| Angular acceleration | ≤ 200,000 rad/s ² |
| Operating torque | 0.2 Ncm |
| Start up torque | + 0.4 Ncm |
| Permissible radial shaft movement | ± 0.6 mm |
| Permissible axial shaft movement | ± 0.95 mm |
| Permissible movement static | ± 0.3 mm, radial ± 0.75 mm, axial |
| Permissible movement dynamic | ± 0.1 mm, radial ± 0.2 mm, axial |
| Angular motion perpendicular to the rotational axis, static | ± 0.005 mm/mm |
| Angular motion perpendicular to the rotational axis, dynamic | ± 0.0025 mm/mm |
| Life of ball bearings | 3.6 x 10 ⁹ revolutions |

Ambient data

| | |
|--|--|
| Operating temperature range | -30 °C ... +115 °C |
| Storage temperature range | -40 °C ... +125 °C, without package |
| Relative humidity/condensation | 90 %, Condensation not permitted |
| Resistance to shocks | 100 g, 10 ms, 10 ms (according to EN 60068-2-27) |
| Frequency range of resistance to vibrations | 20 g, 10 Hz ... 2,000 Hz (EN 60068-2-6) |
| EMC | According to EN 61000-6-2 and EN 61000-6-3 ¹⁾ |
| Enclosure rating | IP40, with mating plug inserted (IEC 60529) |
| Operating height (above sea level) | 2,000 m |

¹⁾ The EMC according to the standards quoted is achieved when the motor feedback system is mounted in an electrically conductive housing, which is connected to the central earthing point of the motor controller via a cable screen. The GND-(0 V) connection of the supply voltage is also grounded here. If other shielding concepts are used, users must perform their own tests.

Certificates

| | |
|-------------------------------------|---|
| EU declaration of conformity | ✓ |
| UK declaration of conformity | ✓ |

| | |
|--|---|
| ACMA declaration of conformity | ✓ |
| Moroccan declaration of conformity | ✓ |
| China RoHS | ✓ |
| EC-Type-Examination approval | ✓ |
| Information according to Art. 3 of Data Act (Regulation EU 2023/2854) | ✓ |

Classifications

| | |
|-----------------------|----------|
| ECLASS 5.0 | 27270590 |
| ECLASS 5.1.4 | 27270590 |
| ECLASS 6.0 | 27270590 |
| ECLASS 6.2 | 27270590 |
| ECLASS 7.0 | 27270590 |
| ECLASS 8.0 | 27270590 |
| ECLASS 8.1 | 27270590 |
| ECLASS 9.0 | 27270590 |
| ECLASS 10.0 | 27273805 |
| ECLASS 11.0 | 27273901 |
| ECLASS 12.0 | 27273901 |
| ETIM 5.0 | EC001486 |
| ETIM 6.0 | EC001486 |
| ETIM 7.0 | EC001486 |
| ETIM 8.0 | EC001486 |
| UNSPSC 16.0901 | 41112113 |

Dimensional drawing Resolver support, tapered shaft

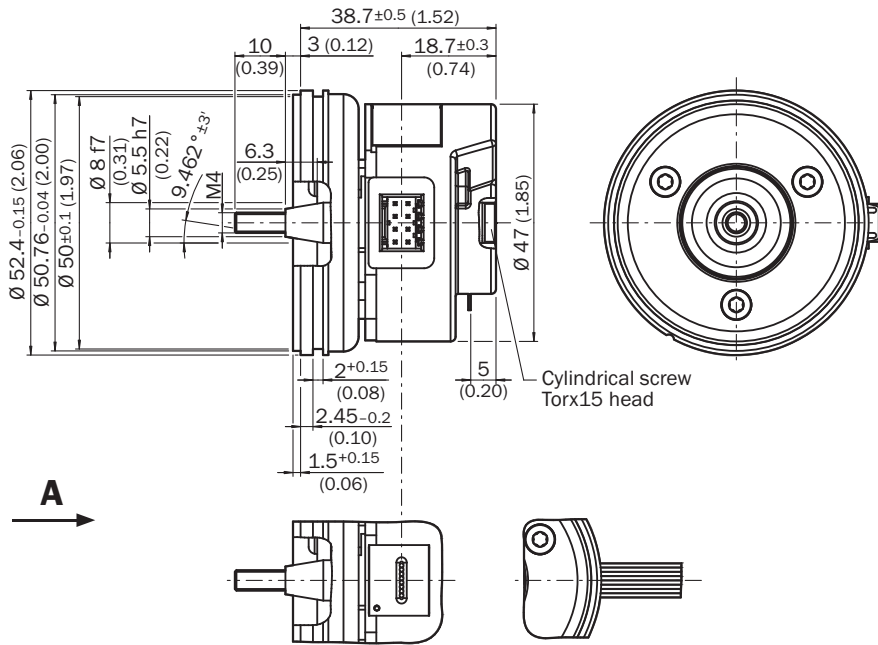

Dimensions in mm (inch)
 General tolerances according to ISO 2768-mk

Anschlussbelegung

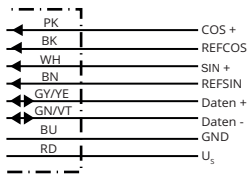

Diagrams Signal diagram for clockwise rotation of the shaft looking in direction "A" (see dimensional drawing) 1 period = 360 ° : 1024

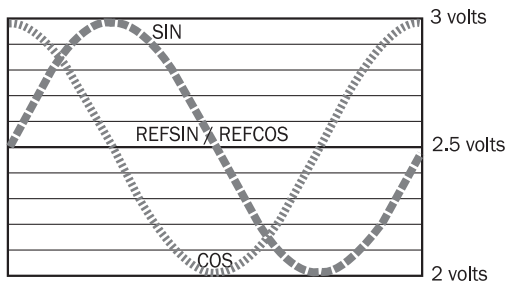

Diagrams Signal specification of the process channel



Signal diagram for clockwise rotation of the shaft looking in direction "A" (see dimensional drawing)
1 period = 360 ° : 1024

Operation note Characteristics applicable to all permissible environmental conditions

| Signal | Values/unit |
|--|-----------------|
| Signal peak, peak V_{SS} of SIN, COS | 0.9 V ... 1.1 V |
| Signal offset REFSIN, REFCOS | 2.2 V ... 2.8 V |

Operation note Overview of supported commands for HIPERFACE®

| Command byte | Function | Code 0 ¹⁾ | SRS Comments | SRM Comments |
|--------------|--|----------------------|---------------------------|---------------------------|
| 42h | Read position | | 15 bit | 27 bit |
| 43h | Set position | ■ | | |
| 44h | Read analog value | | Channel number F0H 48h | Channel number F0H 48h |
| | | | Temperature [°C] | Temperature [°C] |
| 46h | Read counter | | | |
| 47h | Increment Counter | | | |
| 49h | Delete counter | ■ | | |
| 4Ah | Read data | | | |
| 4Bh | Store data | | | |
| 4Ch | Determine status of a data field | | | |
| 4Dh | Create data field | | | |
| 4Eh | Determine available memory area | | | |
| 4Fh | Change access code | | | |
| 50h | Read encoder status | | | |
| 52h | Read out type label | | Encoder type = 22h | Encoder type = 27h |
| 53h | Encoder reset | | | |
| 55h | Allocate encoder address | ■ | | |
| 56h | Read serial number and program version | | | |
| 57h | Configure serial interface | ■ | | |

¹⁾ The commands thus marked include the parameter "Code 0". Code 0 is a byte inserted into the protocol to provide additional protection of vital system parameters against accidental overwriting. When the device is supplied, "Code 0" = 55h.

Operation note Overview of status messages for HIPERFACE®

| | Status code | Description | SRS | SRM |
|----------------|-------------|--|-----|-----|
| Error type | 00h | The encoder has not detected any faults | ■ | ■ |
| Initialization | 01h | Incorrect alignment data | ■ | ■ |
| | 02h | Incorrect internal angular offset | ■ | ■ |
| | 03h | Data field partitioning table destroyed | ■ | ■ |
| | 04h | Analog limit values not available | ■ | ■ |
| | 05h | Internal I2C bus inoperative | ■ | ■ |
| | 06h | Internal checksum error | ■ | ■ |
| Protocol | 07h | Encoder reset occurred as a result of program monitoring | ■ | ■ |
| | 09h | Parity error | ■ | ■ |
| | 0Ah | Checksum of transmitted data is incorrect | ■ | ■ |
| | 0Bh | Unknown command code | ■ | ■ |
| Data | 0Ch | Number of transmitted data is incorrect | ■ | ■ |
| | 0Dh | Transmitted command argument is not allowed | ■ | ■ |
| | 0Eh | The selected data field may not be written to | ■ | ■ |
| | 0Fh | Incorrect access code | ■ | ■ |
| | 10h | Size of specified data field cannot be changed | ■ | ■ |
| | 11h | Specified word address lies outside the data field | ■ | ■ |
| | 12h | Access to non-existent data field | ■ | ■ |
| | 13h | Access to non-existent data field | ■ | ■ |
| Position | 01h | Analog signals outside specification | ■ | ■ |
| | 1Fh | Speed too high, no position formation possible | ■ | ■ |
| | 20h | Singleturn position unreliable | ■ | ■ |
| | 21h | Multiturn position error | | ■ |
| | 22h | Multiturn position error | | ■ |
| Other | 23h | Multiturn position error | | ■ |
| | 1Ch | Value monitoring of the analog signals (process data) | ■ | ■ |
| | 1Dh | Transmitter current critical or P2RAM-Error | ■ | ■ |
| | 1Eh | Encoder temperature critical | ■ | ■ |
| | 08h | Counter overflow | ■ | ■ |

For more information on the interface see HIPERFACE® - description, part no. 8010701

Operation note Model-specific settings

| Type-specific settings | SRS | SRM |
|----------------------------------|-----------|-----------|
| Model ID (command 52h) | 22h | 27h |
| Free E ² PROM [bytes] | 128/1.792 | 128/1.792 |
| Address | 40h | 40h |
| Mode_485 | E4h | E4h |
| Codes 0 to 3 | 55h | 55h |
| Counter | 0 | 0 |

Recommended accessories

Other models and accessories → www.sick.com/SRS_SRM50-S

| | Brief description | Type | part no. |
|---|--|--------------|----------|
| Mounting systems | | | |
| | <ul style="list-style-type: none"> Description: 50 screws for CFS50, SRS50 and SRM50 | BEF-MK-S02 | 2074582 |
| programming devices | | | |
|  | <ul style="list-style-type: none"> Product segment: Programming devices Product: PGT-11-S Description: SVip® LAN programming tool for all motor feedback systems Items supplied: 1x programming tool PGT-11-S LAN, 1x power supply unit 100-240 V AC / 12 V DC, primary adapter (Europe, UK, USA/Japan, Australia), Ethernet cable 3 m | PGT-11-S LAN | 1057324 |

SICK AT A GLANCE

SICK is one of the leading manufacturers of intelligent sensors and sensor solutions for industrial applications. A unique range of products and services creates the perfect basis for controlling processes securely and efficiently, protecting individuals from accidents and preventing damage to the environment.

We have extensive experience in a wide range of industries and understand their processes and requirements. With intelligent sensors, we can deliver exactly what our customers need. In application centers in Europe, Asia and North America, system solutions are tested and optimized in accordance with customer specifications. All this makes us a reliable supplier and development partner.

Comprehensive services complete our offering: SICK LifeTime Services provide support throughout the machine life cycle and ensure safety and productivity.

For us, that is “Sensor Intelligence.”

WORLDWIDE PRESENCE:

Contacts and other locations –www.sick.com