



VISIC620-1411

VISIC620

VISUAL RANGE MEASURING DEVICES

SICK
Sensor Intelligence.



Ordering information

Type	Part no.
VISIC620-1411	1041673

Our regional sales organization will help you to select the optimum device configuration.

Other models and accessories → www.sick.com/VISIC620



Detailed technical data

Technical specifications

Description	Visibility measuring device incl. connecting cable, with male connector, length 5 m, with GSM/GPRS modem, one analog output and two relay contacts
Measured values	Standard visual range, K-value
Maximum number of measurands	1
Measurement principles	Scattered light forward
Spectral range	640 nm ... 660 nm Laser, protection class 2, power < 1 mW
Measuring ranges	Standard visual range 10 ... 500 m / 10 ... 16,000 m Output range freely adjustable
Response time (t₉₀)	2 s ... 300 s
Accuracy	± 5 m For visual range below 50 m ± 10 % Of measured value for visual range below 5,000 m ± 20 % Of measured value for visual range below 16,000 m
Repeatability	± 2 %: for a visual range of 200 m
Ambient temperature	-30 °C ... +55 °C
Storage temperature	-40 °C ... +75 °C
Ambient humidity	0 % ... 100 %
Electrical safety	CE
Enclosure rating	IP69K
Analog outputs	1 output:

	0 ... 20 mA, 500 Ω
Digital outputs	2 relay contacts: 48 V AC, 35 W / 48 V DC, 24 W
Serial	
Type of fieldbus integration	RS-232
Function	Proprietary service interface, connection to SOPAS ET software
Dimensions (W x H x D)	479 mm x 117 mm x 261 mm (for details see dimensional drawings)
Weight	5.6 kg
Material	Stainless steel 1.4571, powder-coated
Energy supply	
Voltage	24 V DC, ± 10 %
Power consumption	≤ 10 W
Test functions	Automatic self-test (contamination, drift, LED, disturbing objects)

Classifications

ECLASS 5.0	27150305
ECLASS 5.1.4	27150305
ECLASS 6.0	27150305
ECLASS 6.2	27150305
ECLASS 7.0	27150305
ECLASS 8.0	27150305
ECLASS 8.1	27150305
ECLASS 9.0	27150305
ECLASS 10.0	27150305
ECLASS 11.0	27150305
ETIM 5.0	EC001190
ETIM 6.0	EC001190
ETIM 7.0	EC001190
ETIM 8.0	EC001190
UNSPSC 16.0901	41115406

Dimensional drawing (Dimensions in mm (inch))

VISIC620 measuring unit

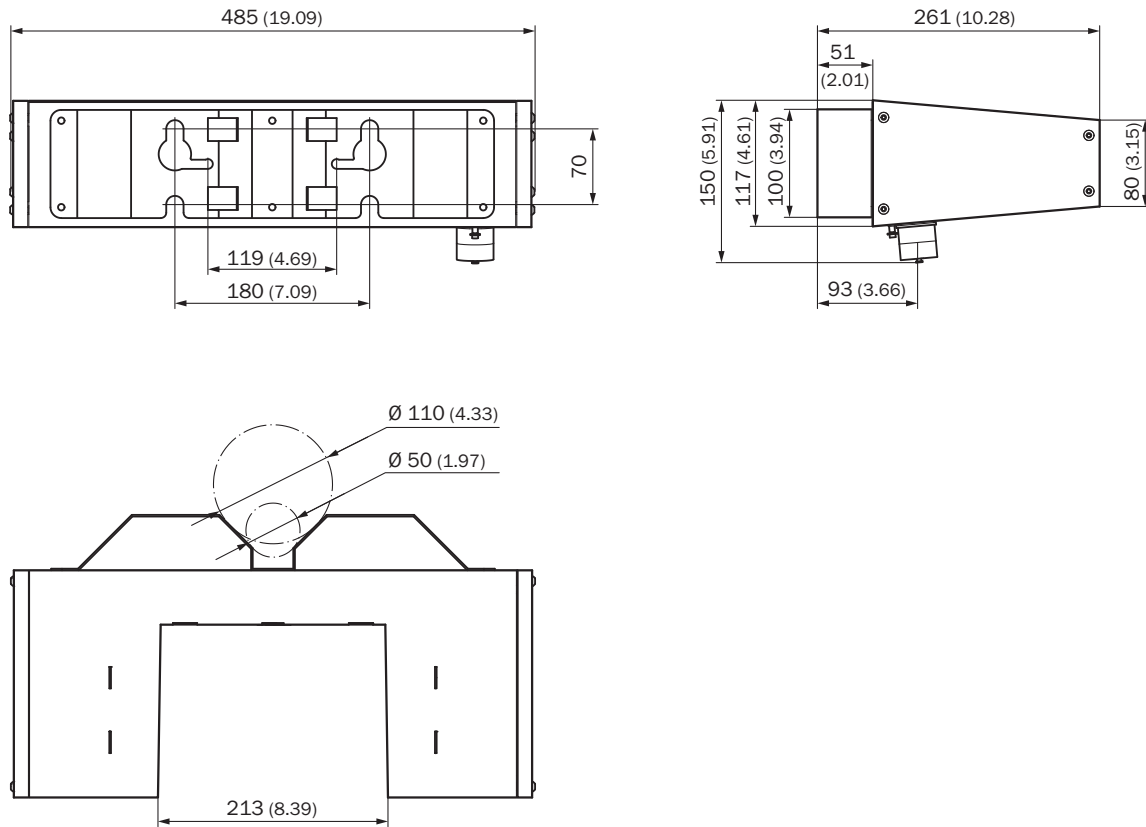

VISIC620 connection unit

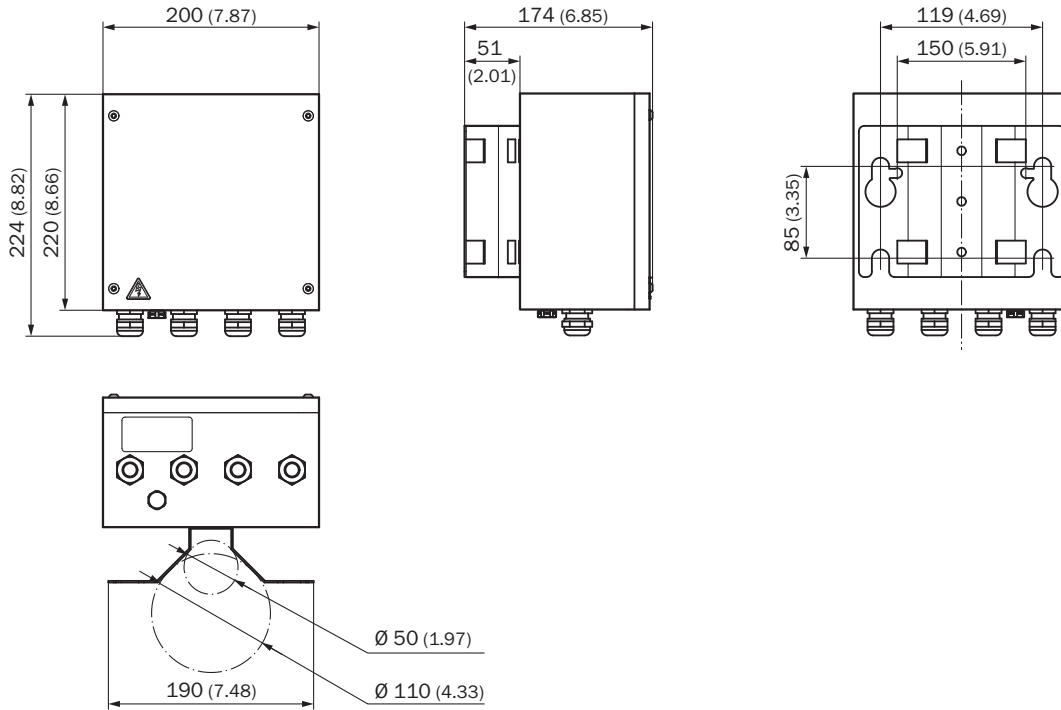

SICK AT A GLANCE

SICK is one of the leading manufacturers of intelligent sensors and sensor solutions for industrial applications. A unique range of products and services creates the perfect basis for controlling processes securely and efficiently, protecting individuals from accidents and preventing damage to the environment.

We have extensive experience in a wide range of industries and understand their processes and requirements. With intelligent sensors, we can deliver exactly what our customers need. In application centers in Europe, Asia and North America, system solutions are tested and optimized in accordance with customer specifications. All this makes us a reliable supplier and development partner.

Comprehensive services complete our offering: SICK LifeTime Services provide support throughout the machine life cycle and ensure safety and productivity.

For us, that is “Sensor Intelligence.”

WORLDWIDE PRESENCE:

Contacts and other locations –www.sick.com