

# ATM90-AXA12x12

ATM90

**ABSOLUTE ENCODERS**

**SICK**  
Sensor Intelligence.



Illustration may differ

### Ordering information

| Type           | part no. |
|----------------|----------|
| ATM90-AXA12x12 | 1030038  |

Other models and accessories → [www.sick.com/ATM90](http://www.sick.com/ATM90)

### Detailed technical data

#### Safety-related parameters

|  |  |
|--|--|
| <b>MTTF<sub>D</sub> (mean time to dangerous failure)</b> | 150 years (EN ISO 13849-1) <sup>1)</sup> |
|--|--|

<sup>1)</sup> This product is a standard product and does not constitute a safety component as defined in the Machinery Directive. Calculation based on nominal load of components, average ambient temperature 40 °C, frequency of use 8760 h/a. All electronic failures are considered hazardous. For more information, see document no. 8015532.

#### Performance

|   |  |
|---|--|
| <b>Number of steps per revolution (max. resolution)</b>                         | 4,096 (12 bit)   |
| <b>Number of revolutions</b>  | 4,096 (12 bit)   |
| <b>Max. resolution (number of steps per revolution x number of revolutions)</b> | 12 bit x 12 bit (4,096 x 4,096)  |
| <b>Resolution</b>   | Ex-works: 4,096 steps x 4,096 revolutions, Gray-Code, Set = 0 factory-programmed. Other configurations on request. |
| <b>Measuring step</b>   | 0.043°   |
| <b>Error limits G</b>   | ± 0.25° <sup>1)</sup>  |
| <b>Repeatability standard deviation <math>\sigma_r</math></b>                   | 0.1° <sup>2)</sup>   |

<sup>1)</sup> In accordance with DIN ISO 1319-1, position of the upper and lower error limit depends on the installation situation, specified value refers to a symmetrical position, i.e. deviation in upper and lower direction is the same.

<sup>2)</sup> In accordance with DIN ISO 55350-13; 68.3% of the measured values are inside the specified area.

#### Interfaces

|   |   |
|---|---|
| <b>Communication interface</b>            | SSI   |
| <b>Initialization time</b>                | 1,050 ms <sup>1)</sup>  |
| <b>Parameterising data</b>                | Number of steps per revolution<br>Number of revolutions<br>Code type<br>Electronic adjustment |
| <b>Code type</b>                          | Gray, binary  |
| <b>Code sequence parameter adjustable</b> | CW/CCW (V/R)  |
| <b>Clock frequency</b>                    | 1 MHz <sup>2)</sup>   |

<sup>1)</sup> Valid positional data can be read once this time has elapsed.

<sup>2)</sup> Minimum, LOW level (Clock +): 500 ns.

|  |  |
|--|--|
| <b>Set (electronic adjustment)</b>             | H-active (L = 0 - 4,7 V, H = 10 - Us V)  |
| <b>CW/CCW (counting sequence when turning)</b> | L-active (L = 0 - 1,5 V, H = 2,0 - Us V) |

<sup>1)</sup> Valid positional data can be read once this time has elapsed.

<sup>2)</sup> Minimum, LOW level (Clock +): 500 ns.

## Electronics

|                                    |                                     |
|------------------------------------|-------------------------------------|
| <b>Connection type</b>             | Male connector, M23, 12-pin, radial |
| <b>Supply voltage</b>              | 10 ... 32 V                         |
| <b>Power consumption</b>           | ≤ 0.8 W (without load)              |
| <b>Reverse polarity protection</b> | ✓                                   |

## Mechanics

|                                       |   |
|---------------------------------------|---|
| <b>Mechanical design</b>              | Through hollow shaft                    |
| <b>Shaft diameter</b>                 | 16 mm                                   |
| <b>Weight</b>                         | 0.8 kg <sup>1)</sup>                    |
| <b>Shaft material</b>                 | Stainless steel                         |
| <b>Flange material</b>                | Aluminum                                |
| <b>Start up torque</b>                | 0.5 Ncm (+20 °C)                        |
| <b>Operating torque</b>               | 0.4 Ncm (+20 °C)                        |
| <b>Operating speed</b>                | ≤ 2,000 min <sup>-1</sup> <sup>2)</sup> |
| <b>Moment of inertia of the rotor</b> | 153.77 gcm <sup>2</sup>                 |
| <b>Bearing lifetime</b>               | 3.6 x 10 <sup>9</sup> revolutions       |
| <b>Angular acceleration</b>           | ≤ 600,000 rad/s <sup>2</sup>            |

<sup>1)</sup> Based on encoder with male connector.

<sup>2)</sup> Allow for self-heating of 3.3 K per 1,000 rpm when designing the operating temperature range.

## Ambient data

|                                      |   |
|--------------------------------------|---|
| <b>EMC</b>                           | According to EN 61000-6-2 and EN 61000-6-3      |
| <b>Enclosure rating</b>              | IP65, with shaft seal (IEC 60529) <sup>1)</sup> |
| <b>Permissible relative humidity</b> | 98 %  |
| <b>Operating temperature range</b>   | -20 °C ... +70 °C                               |
| <b>Storage temperature range</b>     | -40 °C ... +100 °C, without package             |
| <b>Resistance to shocks</b>          | 100 g, 6 ms (EN 60068-2-27)                     |
| <b>Resistance to vibration</b>       | 20 g, ≥ 10 Hz (EN 60068-2-6)                    |

<sup>1)</sup> With mating connector fitted.

## Classifications

|                     |          |
|---------------------|----------|
| <b>ECLASS 5.0</b>   | 27270502 |
| <b>ECLASS 5.1.4</b> | 27270502 |
| <b>ECLASS 6.0</b>   | 27270590 |
| <b>ECLASS 6.2</b>   | 27270590 |
| <b>ECLASS 7.0</b>   | 27270502 |
| <b>ECLASS 8.0</b>   | 27270502 |

|                       |          |
|-----------------------|----------|
| <b>ECLASS 8.1</b>     | 27270502 |
| <b>ECLASS 9.0</b>     | 27270502 |
| <b>ECLASS 10.0</b>    | 27270502 |
| <b>ECLASS 11.0</b>    | 27270502 |
| <b>ECLASS 12.0</b>    | 27270502 |
| <b>ETIM 5.0</b>       | EC001486 |
| <b>ETIM 6.0</b>       | EC001486 |
| <b>ETIM 7.0</b>       | EC001486 |
| <b>ETIM 8.0</b>       | EC001486 |
| <b>UNSPSC 16.0901</b> | 41112113 |

Dimensional drawing

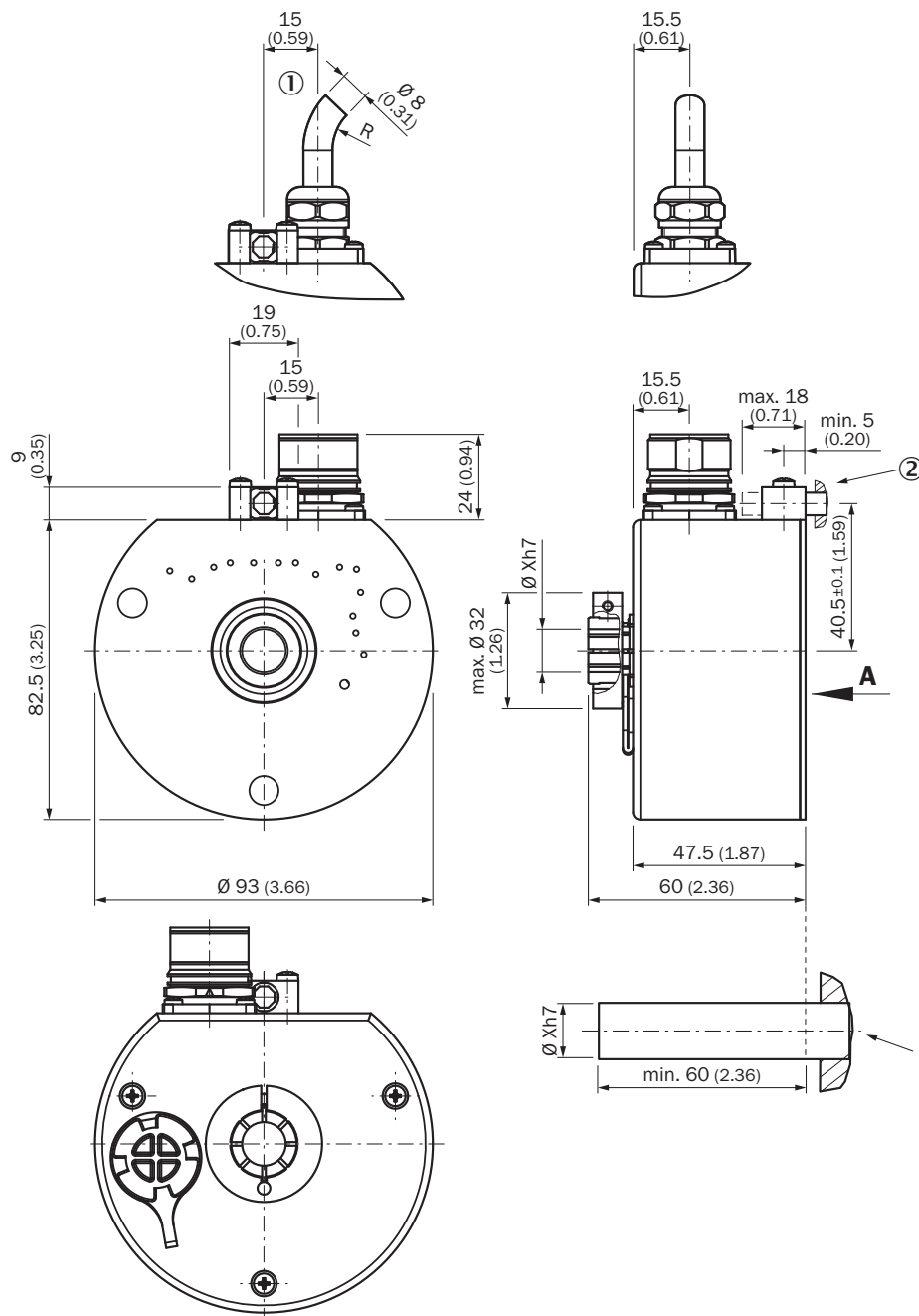

Dimensions in mm (inch)

① Minimum bend radius 40 mm

② Torque support of the encoder via cylindrical pin  $\varnothing 6$  mm DIN EN 28734 provided by the customer

### view of M23 male device connector on encoder

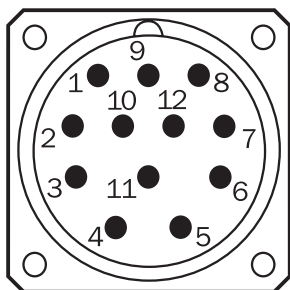

view of M23 male device connector on encoder

| PIN | Signal            | Wire colors (cable connection) | Explanation                       |
|-----|-------------------|--------------------------------|-----------------------------------|
| 1   | GND               | Blue                           | Ground connection                 |
| 2   | Data +            | White                          | Interface signals                 |
| 3   | Clock +           | Yellow                         | Interface signals                 |
| 4   | R x D +           | Gray                           | RS-422 programming lines          |
| 5   | R x D -           | Green                          | RS-422 programming lines          |
| 6   | T x D +           | Pink                           | RS-422 programming lines          |
| 7   | T x D -           | Black                          | RS-422 programming lines          |
| 8   | U <sub>S</sub>    | Red                            | Operating voltage                 |
| 9   | SET <sup>1)</sup> | Orange                         | Electronic adjustment             |
| 10  | Data -            | Brown                          | Interface signals                 |
| 11  | Clock -           | Purple                         | Interface signals                 |
| 12  | V/R <sup>2)</sup> | Orange-black                   | Sequence in direction of rotation |
| -   | Screen            | -                              | Housing potential                 |







SET = This input activates the electronic zero set. If the SET cable is set to U<sub>S</sub> for more than 100 ms, the mechanical position corresponds to the 0 value, i.e., the predetermined SET value.

V/R = Forwards/Reverse: This input programs the counting direction for the encoder. When it is not connected, this input is set to HIGH. If the encoder shaft is rotated clockwise (to the right) as viewed when facing the shaft, it counts in ascending order. If it should count in ascending order when the shaft is rotated counterclockwise (to the left), then this connection must be permanently set to LOW level (GND).

### Recommended accessories

Other models and accessories → [www.sick.com/ATM90](http://www.sick.com/ATM90)

|   | Brief description   | Type     | part no. |
|---|---|----------|----------|
| programming devices   |   |          |          |
|  | <ul style="list-style-type: none"> <li><b>Product segment:</b> Programming devices</li> <li><b>Product:</b> PGT-01-S</li> <li><b>Description:</b> Programming tool for ATM60, ATM90, and KH53</li> <li><b>Items supplied:</b> Power supply, interface, link cable, encoder cable, and software</li> </ul> | PGT-01-S | 1030111  |

|   | Brief description   | Type         | part no. |
|---|---|--------------|----------|
| connectors and cables   |   |              |          |
|  | <ul style="list-style-type: none"> <li><b>Description:</b> SSI, shielded, Incremental</li> <li><b>Connection type head A:</b> Flying leads</li> <li><b>Connection type head B:</b> Flying leads</li> <li><b>Signal type:</b> SSI, Incremental</li> <li><b>Items supplied:</b> By the meter</li> <li><b>Cable:</b> 12-wire, PUR, halogen-free</li> </ul>   | LTG-2512-MW  | 6027531  |
|  | <ul style="list-style-type: none"> <li><b>Description:</b> SSI, shielded, TTL, HTL, Incremental</li> <li><b>Connection type head A:</b> Flying leads</li> <li><b>Connection type head B:</b> Flying leads</li> <li><b>Signal type:</b> SSI, TTL, HTL, Incremental</li> <li><b>Items supplied:</b> By the meter</li> <li><b>Cable:</b> 12-wire, UV and saltwater-resistant, PUR, halogen-free</li> </ul> | LTG-2612-MW  | 6028516  |
|  | <ul style="list-style-type: none"> <li><b>Description:</b> HIAPERFACE<sup>®</sup>, shielded, SSI, Incremental</li> <li><b>Connection type head A:</b> Female connector, M23, 12-pin, straight, A-coded</li> <li><b>Signal type:</b> HIAPERFACE<sup>®</sup>, SSI, Incremental</li> <li><b>Connection systems:</b> Solder connection</li> </ul>   | DOS-2312-G   | 6027538  |
|  | <ul style="list-style-type: none"> <li><b>Description:</b> HIAPERFACE<sup>®</sup>, shielded, SSI, Incremental, RS-422</li> <li><b>Connection type head A:</b> Male connector, M23, 12-pin, straight, A-coded</li> <li><b>Signal type:</b> HIAPERFACE<sup>®</sup>, SSI, Incremental, RS-422</li> <li><b>Connection systems:</b> Solder connection</li> </ul>   | STE-2312-G   | 6027537  |
|  | <ul style="list-style-type: none"> <li><b>Description:</b> HIAPERFACE<sup>®</sup>, shielded, SSI, Incremental</li> <li><b>Connection type head A:</b> Female connector, M23, 9-pin, straight, A-coded</li> <li><b>Signal type:</b> HIAPERFACE<sup>®</sup>, SSI, Incremental</li> <li><b>Connection systems:</b> Solder connection</li> </ul>  | DOS-2309-G   | 6028533  |
|  | <ul style="list-style-type: none"> <li><b>Description:</b> HIAPERFACE<sup>®</sup>, shielded, SSI, Incremental</li> <li><b>Connection type head A:</b> Female connector, M23, 12-pin, angled, A-coded</li> <li><b>Signal type:</b> HIAPERFACE<sup>®</sup>, SSI, Incremental</li> <li><b>Connection systems:</b> Solder connection</li> </ul>   | DOS-2312-W01 | 2072580  |

## SICK AT A GLANCE

SICK is one of the leading manufacturers of intelligent sensors and sensor solutions for industrial applications. A unique range of products and services creates the perfect basis for controlling processes securely and efficiently, protecting individuals from accidents and preventing damage to the environment.

We have extensive experience in a wide range of industries and understand their processes and requirements. With intelligent sensors, we can deliver exactly what our customers need. In application centers in Europe, Asia and North America, system solutions are tested and optimized in accordance with customer specifications. All this makes us a reliable supplier and development partner.

Comprehensive services complete our offering: SICK LifeTime Services provide support throughout the machine life cycle and ensure safety and productivity.

For us, that is “Sensor Intelligence.”

## WORLDWIDE PRESENCE:

Contacts and other locations –[www.sick.com](http://www.sick.com)