



UE1840-22H0000

EFI gateways

NETWORK DEVICES

SICK
Sensor Intelligence.



Ordering information

Type	part no.
UE1840-22H0000	1029100

Other models and accessories → www.sick.com/EFI_gateways

Detailed technical data

Technical specifications

Accessory family	EFI gateways
Enclosure rating	IP20 (IEC 60529)
Weight	120 g
Dimensions (W x H x L)	22.5 mm x 99 mm x 113.6 mm
Description	Ethernet TCP/IP

Classifications

ECLASS 5.0	27242205
ECLASS 5.1.4	27242605
ECLASS 6.0	27242605
ECLASS 6.2	27242605
ECLASS 7.0	27242605
ECLASS 8.0	27242605
ECLASS 8.1	27242605
ECLASS 9.0	27242605
ECLASS 10.0	27242605
ECLASS 11.0	27242605
ECLASS 12.0	27242605
ETIM 5.0	EC001601
ETIM 6.0	EC001601
ETIM 7.0	EC001601
ETIM 8.0	EC001601
UNSPSC 16.0901	32151705

Dimensional drawing

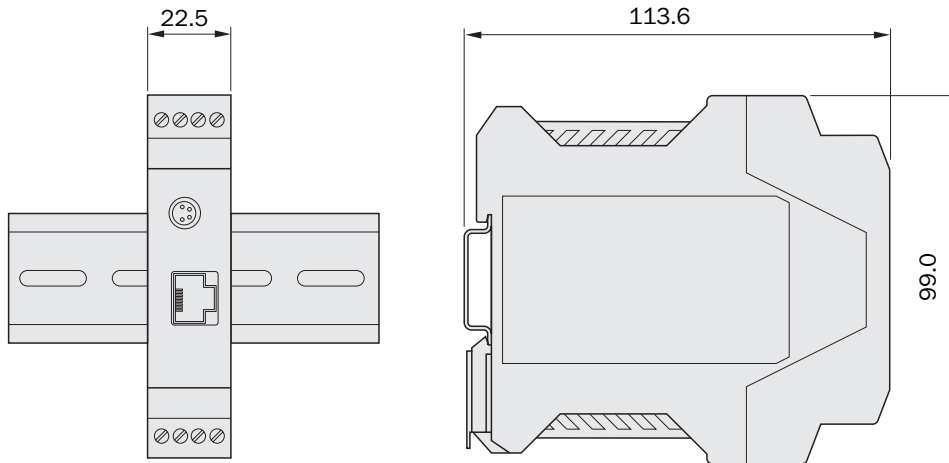

Dimensions in mm (inch)

Anschlusschema

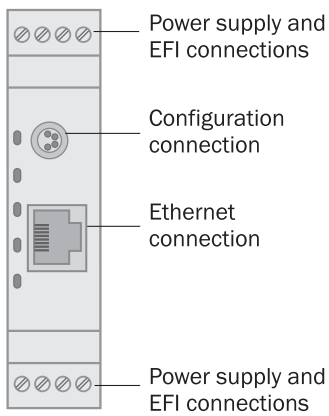

SICK AT A GLANCE

SICK is one of the leading manufacturers of intelligent sensors and sensor solutions for industrial applications. A unique range of products and services creates the perfect basis for controlling processes securely and efficiently, protecting individuals from accidents and preventing damage to the environment.

We have extensive experience in a wide range of industries and understand their processes and requirements. With intelligent sensors, we can deliver exactly what our customers need. In application centers in Europe, Asia and North America, system solutions are tested and optimized in accordance with customer specifications. All this makes us a reliable supplier and development partner.

Comprehensive services complete our offering: SICK LifeTime Services provide support throughout the machine life cycle and ensure safety and productivity.

For us, that is “Sensor Intelligence.”

WORLDWIDE PRESENCE:

Contacts and other locations –www.sick.com