



# WTT190LC-B2233A00

WTT190 PowerProx

TIME-OF-FLIGHT SENSORS

**SICK**  
Sensor Intelligence.



Illustration may differ



### Ordering information

Type	part no.
WTT190LC-B2233A00	6067745

**Included in delivery:** BEF-W190 (1)

Other models and accessories → [www.sick.com/WTT190\\_PowerProx](http://www.sick.com/WTT190_PowerProx)

### Detailed technical data

#### Features

<b>Functional principle</b>	Photoelectric proximity sensor
<b>Functional principle detail</b>	Background suppression, Optical time-of-flight, distance value
<b>Housing design (light emission)</b>	Rectangular
<b>Sensing range max.</b>	200 mm ... 3,000 mm <sup>1)</sup>
<b>Sensing range</b>	200 mm ... 3,000 mm <sup>2)</sup> <sup>1)</sup>
<b>Type of light</b>	Visible red light
<b>Light source</b>	Laser <sup>3)</sup>
<b>Light spot size (distance)</b>	Ø 12 mm (3,000 mm)
<b>Wave length</b>	658 nm
<b>Laser class</b>	1 (IEC 60825-1 / CDRH 21 CFR 1040.10 & 1040.11) <sup>4)</sup>
<b>Adjustment</b>	Single teach-in button (2 x), local user interface with display and button (2 x), IO-Link
<b>Pin 2 configuration</b>	External input, Teach-in input, Sender off input, Detection output, logic output
<b>Items supplied</b>	BEF-W190 mounting bracket
<b>Safety-related parameters</b>	
	MTTF <sub>D</sub> 170.9 years
	DC <sub>avg</sub> 0 %

<sup>1)</sup> Object with 6 ... 90% remission (based on standard white, DIN 5033).

<sup>2)</sup> Adjustable.

<sup>3)</sup> Average service life: 100,000 h at T<sub>U</sub> = +25 °C.

<sup>4)</sup> Do not intentionally look into the laser beam. Never point the laser beam at people's eyes.

#### Interfaces

<b>Communication interface</b>	IO-Link V1.1
--------------------------------	--------------

<b>Communication Interface detail</b>	COM3 (230,4 kBaud)
<b>Cycle time</b>	1 ms
<b>Process data length</b>	32 Bit
<b>Process data structure</b>	Bit 0 = switching signal Q <sub>L1</sub> Bit 1 = switching signal Q <sub>L2</sub> Bit 2 = detection signal Q <sub>int.1</sub> Bit 3 = detection signal Q <sub>int.2</sub> Bit 4 = detection signal Q <sub>int.3</sub> Bit 5 = detection signal Q <sub>int.4</sub> Bit 6 = detection signal Q <sub>int.5</sub> Bit 7 = detection signal Q <sub>int.6</sub> Bit 8 = detection signal Q <sub>int.7</sub> Bit 9 = detection signal Q <sub>int.8</sub> Bit 10 ... 15 = empty Bit 16 ... 31 = distance value
<b>VendorID</b>	26
<b>DeviceID HEX</b>	0x8001D3
<b>DeviceID DEC</b>	8389075

## Electronics

<b>Supply voltage U<sub>B</sub></b>	10 V DC ... 30 V DC <sup>1)</sup>
<b>Ripple</b>	< 5 V <sub>pp</sub> <sup>2)</sup>
<b>Current consumption</b>	75 mA <sup>3)</sup>
<b>Switching output</b>	Push-pull: PNP/NPN <sup>4)</sup> <sup>5)</sup>
<b>Number of switching outputs</b>	2 (Q <sub>1</sub> , Q <sub>2</sub> ) <sup>4)</sup>
<b>Switching mode</b>	Light/dark switching <sup>4)</sup>
<b>Switching mode selector</b>	Selectable via menu
<b>Output current I<sub>max.</sub></b>	≤ 100 mA
<b>Response time</b>	0.6 ms <sup>6)</sup> 0.8 ms <sup>7)</sup> 1 ms <sup>8)</sup> 1.8 ms 3.4 ms 6.6 ms 13 ms 25.8 ms 51.4 ms 102.6 ms

<sup>1)</sup> Limit values. Operated in short-circuit protected network: max. 8 A.

<sup>2)</sup> May not fall below or exceed U<sub>V</sub> tolerances.

<sup>3)</sup> Without load. At V<sub>S</sub> = 24 V.

<sup>4)</sup> Q<sub>1</sub>, Q<sub>2</sub> = 2 switching thresholds, light/dark switching selectable via light/dark selector.

<sup>5)</sup> PNP/NPN switchable.

<sup>6)</sup> Signal transit time with resistive load.

<sup>7)</sup> Can be set via a mean value filter (AVG1, AVG2, AVG4, AVG8, AVG16, AVG32, AVG64, AVG128, AVG256, AVG512).

<sup>8)</sup> Depending on distance to object, distance to background and selected switching threshold.

<sup>9)</sup> With light/dark ratio 1:1.

<sup>10)</sup> A = V<sub>S</sub> connections reverse-polarity protected.

<sup>11)</sup> B = inputs and output reverse-polarity protected.

<sup>12)</sup> C = interference suppression.

<sup>13)</sup> For optimum performance observe max. warm-up time of 5 minutes.

<b>Switching frequency</b>	833 Hz, 625 Hz, 500 Hz, 278 Hz, 147 Hz, 76 Hz, 38 Hz, 19 Hz, 10 Hz, 4.9 Hz <sup>7) 8) 9)</sup>
<b>Analog output</b>	-
<b>Input</b>	MF = multifunctional input and output, programmable
<b>Circuit protection</b>	A <sup>10)</sup> B <sup>11)</sup> C <sup>12)</sup>
<b>Protection class</b>	III
<b>Enclosure rating</b>	IP67
<b>Warm-up time</b>	< 5 min <sup>13)</sup>
<b>Initialization time</b>	< 300 ms

<sup>1)</sup> Limit values. Operated in short-circuit protected network: max. 8 A.

<sup>2)</sup> May not fall below or exceed  $U_V$  tolerances.

<sup>3)</sup> Without load. At  $V_S = 24$  V.

<sup>4)</sup> Q1, Q2 = 2 switching thresholds, light/dark switching selectable via light/dark selector.

<sup>5)</sup> PNP/NPN switchable.

<sup>6)</sup> Signal transit time with resistive load.

<sup>7)</sup> Can be set via a mean value filter (AVG1, AVG2, AVG4, AVG8, AVG16, AVG32, AVG64, AVG128, AVG256, AVG512).

<sup>8)</sup> Depending on distance to object, distance to background and selected switching threshold.

<sup>9)</sup> With light/dark ratio 1:1.

<sup>10)</sup> A =  $V_S$  connections reverse-polarity protected.

<sup>11)</sup> B = inputs and output reverse-polarity protected.

<sup>12)</sup> C = interference suppression.

<sup>13)</sup> For optimum performance observe max. warm-up time of 5 minutes.

### Mechanics

<b>Dimensions (W x H x D)</b>	17.4 mm x 45.6 mm x 34.7 mm
<b>Housing material</b>	Plastic, ABS
<b>Optics material</b>	Plastic, PMMA
<b>Weight</b>	25 g
<b>Connection type</b>	Male connector M8, 4-pin

### Ambient data

<b>Ambient operating temperature</b>	-30 °C ... +50 °C <sup>1)</sup>
<b>Ambient temperature, storage</b>	-40 °C ... +70 °C

<sup>1)</sup>  $U_V \geq 24$  V. At  $T_u < -10$  °C warm-up time < 10 min.

### Smart Task

<b>Smart Task name</b>	Base logics
<b>Logic function</b>	Direct AND OR WINDOW Hysteresis
<b>Timer function</b>	Deactivated Switch-on delay Off delay ON and OFF delay Impulse (one shot)
<b>Inverter</b>	Yes
<b>Switching signal</b>	

Switching signal Q <sub>L1</sub>	Switching output
Switching signal Q <sub>L2</sub>	Switching output

### Certificates

<b>EU declaration of conformity</b>	✓
<b>UK declaration of conformity</b>	✓
<b>ACMA declaration of conformity</b>	✓
<b>Moroccan declaration of conformity</b>	✓
<b>China RoHS</b>	✓
<b>cULus certificate</b>	✓
<b>Laser safety (IEC 60825-1) certificate</b>	✓
<b>Information according to Art. 3 of Data Act (Regulation EU 2023/2854)</b>	✓

### Classifications

<b>ECLASS 5.0</b>	27270904
<b>ECLASS 5.1.4</b>	27270904
<b>ECLASS 6.0</b>	27270904
<b>ECLASS 6.2</b>	27270904
<b>ECLASS 7.0</b>	27270904
<b>ECLASS 8.0</b>	27270904
<b>ECLASS 8.1</b>	27270904
<b>ECLASS 9.0</b>	27270904
<b>ECLASS 10.0</b>	27270904
<b>ECLASS 11.0</b>	27270904
<b>ECLASS 12.0</b>	27270903
<b>ETIM 5.0</b>	EC002719
<b>ETIM 6.0</b>	EC002719
<b>ETIM 7.0</b>	EC002719
<b>ETIM 8.0</b>	EC002719
<b>UNSPSC 16.0901</b>	39121528

### Dimensional drawing

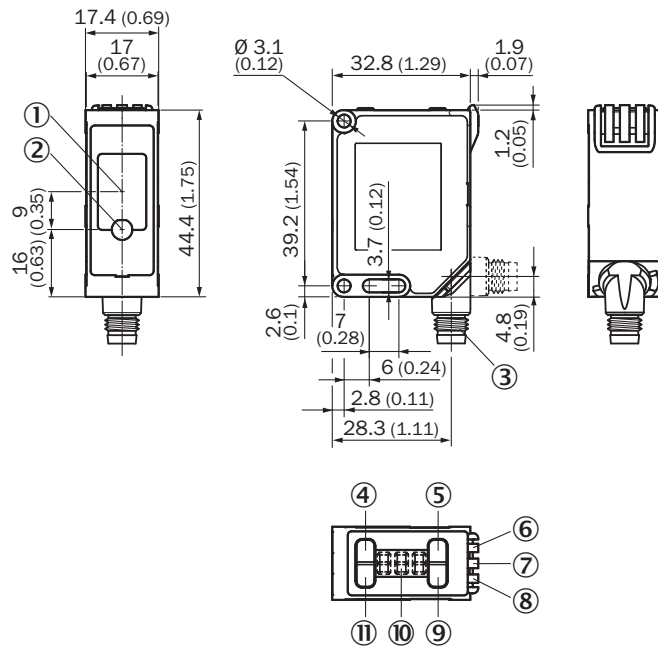

Dimensions in mm (inch)

- ① receiver
- ② sender
- ③ Connection
- ④ RUN button
- ⑤ (+/Q2) button
- ⑥ Status indicator orange: Q2 output indicator
- ⑦ Status indicator LED, green/red: power on / stability indicator
- ⑧ Status indicator orange: Q1 output indicator
- ⑨ (-/Q1) button
- ⑩ Display
- ⑪ SET button

### Connection diagram Cd-278

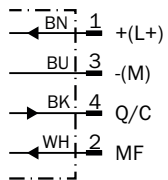

Characteristic curve

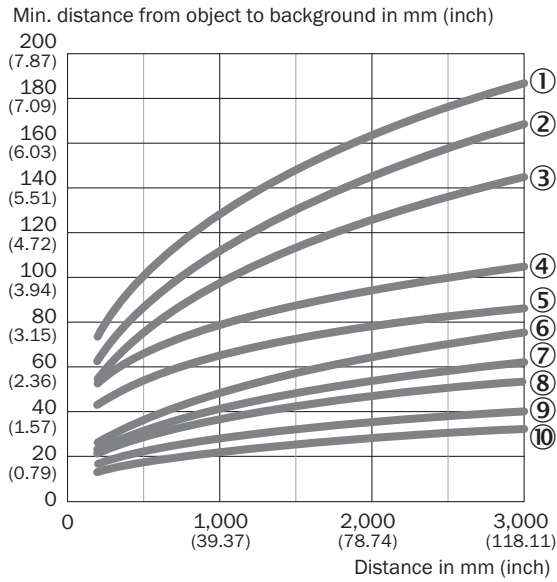

- ① 90 % / 90 % AVG1
- ② 90 % / 90 % AVG2
- ③ 90 % / 90 % AVG4
- ④ 90 % / 90 % AVG8
- ⑤ 90 % / 90 % AVG16
- ⑥ 90 % / 90 % AVG32
- ⑦ 90 % / 90 % AVG64
- ⑧ 90 % / 90 % AVG128
- ⑨ 90 % / 90 % AVG256
- ⑩ 90 % / 90 % AVG512

Characteristic curve

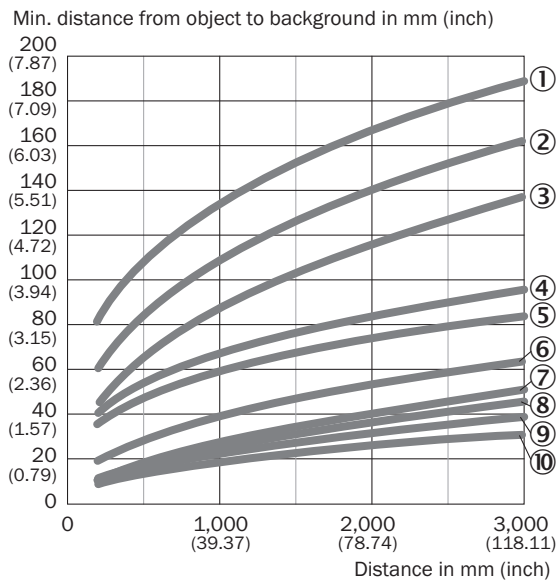

- ① 6 % / 90 % AVG1
- ② 6 % / 90 % AVG2
- ③ 6 % / 90 % AVG4

- ④ 6 % / 90 % AVG8
- ⑤ 6 % / 90 % AVG16
- ⑥ 6 % / 90 % AVG32
- ⑦ 6 % / 90 % AVG64
- ⑧ 6 % / 90 % AVG128
- ⑨ 6 % / 90 % AVG256
- ⑩ 6 % / 90 % AVG512

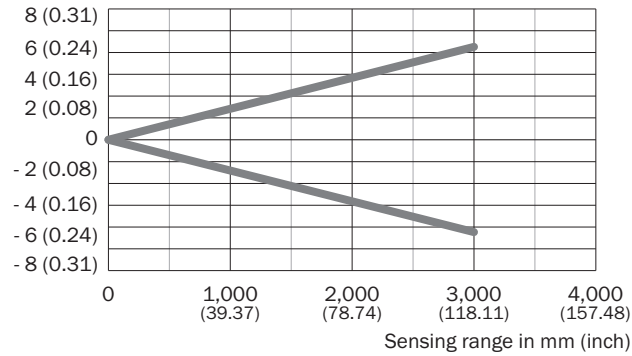

### Light spot size

Radius mm (inch)



### Recommended accessories

Other models and accessories → [www.sick.com/WTT190\\_PowerProx](http://www.sick.com/WTT190_PowerProx)

	Brief description	Type	part no.
connectors and cables			
	<ul style="list-style-type: none"> <li>• <b>Description:</b> Sensor/actuator cable, unshielded</li> <li>• <b>Connection type head A:</b> Female connector, M8, 4-pin, straight, A-coded</li> <li>• <b>Connection type head B:</b> Flying leads</li> <li>• <b>Signal type:</b> Sensor/actuator cable</li> <li>• <b>Cable:</b> 5 m, 4-wire, PVC</li> <li>• <b>Application:</b> Untaminated zones, Zones with chemicals</li> </ul>	YF8U14-050VA3XLEAX	2095889
	<ul style="list-style-type: none"> <li>• <b>Description:</b> Unshielded</li> <li>• <b>Connection type head A:</b> Male connector, M8, 4-pin, straight, A-coded</li> <li>• <b>Connection systems:</b> Screw-type terminals</li> <li>• <b>Permitted cross-section:</b> 0.14 mm<sup>2</sup> ... 0.5 mm<sup>2</sup></li> </ul>	STE-0804-G	6037323

## SICK AT A GLANCE

SICK is one of the leading manufacturers of intelligent sensors and sensor solutions for industrial applications. A unique range of products and services creates the perfect basis for controlling processes securely and efficiently, protecting individuals from accidents and preventing damage to the environment.

We have extensive experience in a wide range of industries and understand their processes and requirements. With intelligent sensors, we can deliver exactly what our customers need. In application centers in Europe, Asia and North America, system solutions are tested and optimized in accordance with customer specifications. All this makes us a reliable supplier and development partner.

Comprehensive services complete our offering: SICK LifeTime Services provide support throughout the machine life cycle and ensure safety and productivity.

For us, that is “Sensor Intelligence.”

## WORLDWIDE PRESENCE:

Contacts and other locations –[www.sick.com](http://www.sick.com)