

# OD5000-C85W20

OD5000

DISPLACEMENT MEASUREMENT SENSORS

**SICK**  
Sensor Intelligence.



### Ordering information

Type	part no.
OD5000-C85W20	6063624

Other models and accessories → [www.sick.com/OD5000](http://www.sick.com/OD5000)



### Detailed technical data

#### Features

<b>Measuring range</b>	65 mm ... 105 mm <sup>1)</sup>
<b>Repeatability</b>	0.1 μm <sup>2) 3)</sup>
<b>Linearity</b>	Diffuse ± 6 μm <sup>2)</sup> Specular ± 6 μm
<b>Response time</b>	≥ 0.0125 ms <sup>4) 5)</sup>
<b>Measuring frequency</b>	≤ 80 kHz <sup>6)</sup>
<b>Output time</b>	≥ 0.0125 ms
<b>Emitted beam</b>	
Light source	Laser, red
Typ. light spot size (distance)	70 μm x 2,000 μm
<b>Key laser figures</b>	
Normative reference	IEC 60825-1:2014, EN 60825-1:2014
Laser class	1 <sup>7)</sup> 8)
<b>Special task</b>	Thickness measurement of transparent material
<b>Thickness measurement of transparent material</b>	0.5 mm ... 2 mm
<b>Safety-related parameters</b>	

<sup>1)</sup> If there are reflections, the measuring range is reduced to 71.5 ... 91.5 mm.

<sup>2)</sup> Measurement on 60 % remission (ceramic, white).

<sup>3)</sup> Set average: 65536, median: 31, response time: 50 μs, constant application parameters.

<sup>4)</sup> At 0.0125 ms, measurement is only possible within a sub-range.

<sup>5)</sup> Dependent on the set average or sensitivity.

<sup>6)</sup> At 80 kHz, measurement is only possible in a sub-area.

<sup>7)</sup> Visible, wavelength: 655 nm, max. power: 0.39 mW.

<sup>8)</sup> Do not intentionally look into the laser beam. Never point the laser beam at people's eyes.

MTTF <sub>D</sub>	61 years
DC <sub>avg</sub>	0%

- 1) If there are reflections, the measuring range is reduced to 71.5 ... 91.5 mm.
- 2) Measurement on 60 % remission (ceramic, white).
- 3) Set average: 65536, median: 31, response time: 50 µs, constant application parameters.
- 4) At 0.0125 ms, measurement is only possible within a sub-range.
- 5) Dependent on the set average or sensitivity.
- 6) At 80 kHz, measurement is only possible in a sub-area.
- 7) Visible, wavelength: 655 nm, max. power: 0.39 mW.
- 8) Do not intentionally look into the laser beam. Never point the laser beam at people's eyes.

## Interfaces

<b>Ethernet</b>	✓ , TCP/IP, UDP
<b>Digital input</b>	In <sub>1</sub> Can be used as laser off, external teach-in, or deactivated
<b>Digital output</b>	
Number	1 ... 3 <sup>1)</sup>
Type	PNP/NPN, selectable
<b>Analog output</b>	
Number	1
Type	Current output
Function	Optional over evaluation unit AOD1
Current	4 mA ... 20 mA, ≤ 300 Ω

<sup>1)</sup> Optional over evaluation unit AOD1.

## Electronics

<b>Supply voltage U<sub>B</sub></b>	DC 12 V ... 24 V, ± 10%, including residual ripple
<b>Power consumption</b>	180 mA, at 24 V
<b>Warm-up time</b>	< 10 min
<b>Display</b>	Status LEDs
<b>Enclosure rating</b>	IP67
<b>Protection class</b>	III (EN 50178)
<b>Connection type</b>	Cable with male connector, 50 cm

## Mechanics

<b>Dimensions (W x H x D)</b>	25.9 mm x 71.5 mm x 53.2 mm
<b>Housing material</b>	Metal (Aluminum die cast)
<b>Window material</b>	Plastic (PMMA)
<b>Weight</b>	280 g

## Ambient data

<b>Ambient temperature, operation</b>	-10 °C ... +50 °C, Operating temperature at V <sub>S</sub> = 24 V
<b>Ambient temperature, storage</b>	-20 °C ... +60 °C
<b>Relative air humidity (non-condensing)</b>	35 % ... 85 %

<sup>1)</sup> With constant object movement in the measuring range.

<b>Temperature drift</b>	± 0.01 % FS/K at -10 °C ... +40 °C (FS = Full Scale = sensor measuring range) ± 0.03 % FS/K at +40 °C ... +50 °C (FS = Full Scale = sensor measuring range)
<b>Typ. Ambient light immunity</b>	Artificial light: ≤ 3,000 lx <sup>1)</sup> Sunlight: ≤ 10,000 lx
<b>Vibration resistance</b>	EN 60068-2-6, EN 60068-2-64
<b>Shock resistance</b>	EN 60068-2-27

<sup>1)</sup> With constant object movement in the measuring range.

### Certificates

<b>EU declaration of conformity</b>	✓
<b>UK declaration of conformity</b>	✓
<b>ACMA declaration of conformity</b>	✓
<b>Moroccan declaration of conformity</b>	✓
<b>China RoHS</b>	✓
<b>Information according to Art. 3 of Data Act (Regulation EU 2023/2854)</b>	✓

### Classifications

<b>ECLASS 5.0</b>	27270801
<b>ECLASS 5.1.4</b>	27270801
<b>ECLASS 6.0</b>	27270801
<b>ECLASS 6.2</b>	27270801
<b>ECLASS 7.0</b>	27270801
<b>ECLASS 8.0</b>	27270801
<b>ECLASS 8.1</b>	27270801
<b>ECLASS 9.0</b>	27270801
<b>ECLASS 10.0</b>	27270801
<b>ECLASS 11.0</b>	27270801
<b>ECLASS 12.0</b>	27270916
<b>ETIM 5.0</b>	EC001825
<b>ETIM 6.0</b>	EC001825
<b>ETIM 7.0</b>	EC001825
<b>ETIM 8.0</b>	EC001825
<b>UNSPSC 16.0901</b>	41111613

Dimensional drawing OD5000-C85x20

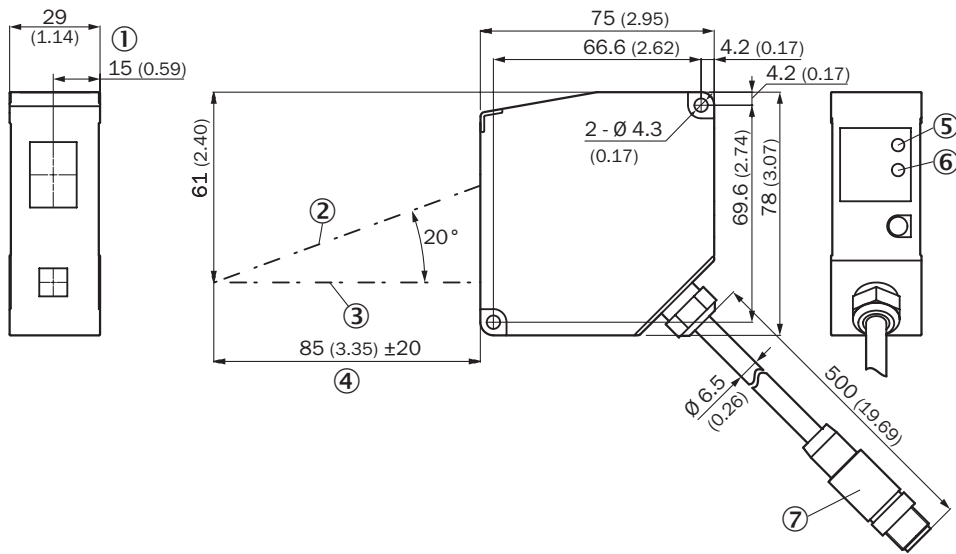

Dimensions in mm (inch)

- ① reference edge
- ② optical axis, receiver
- ③ optical axis, sender
- ④ measuring range
- ⑤ Link LED
- ⑥ status LED
- ⑦ male connector M12, 8-pin

Connection diagram

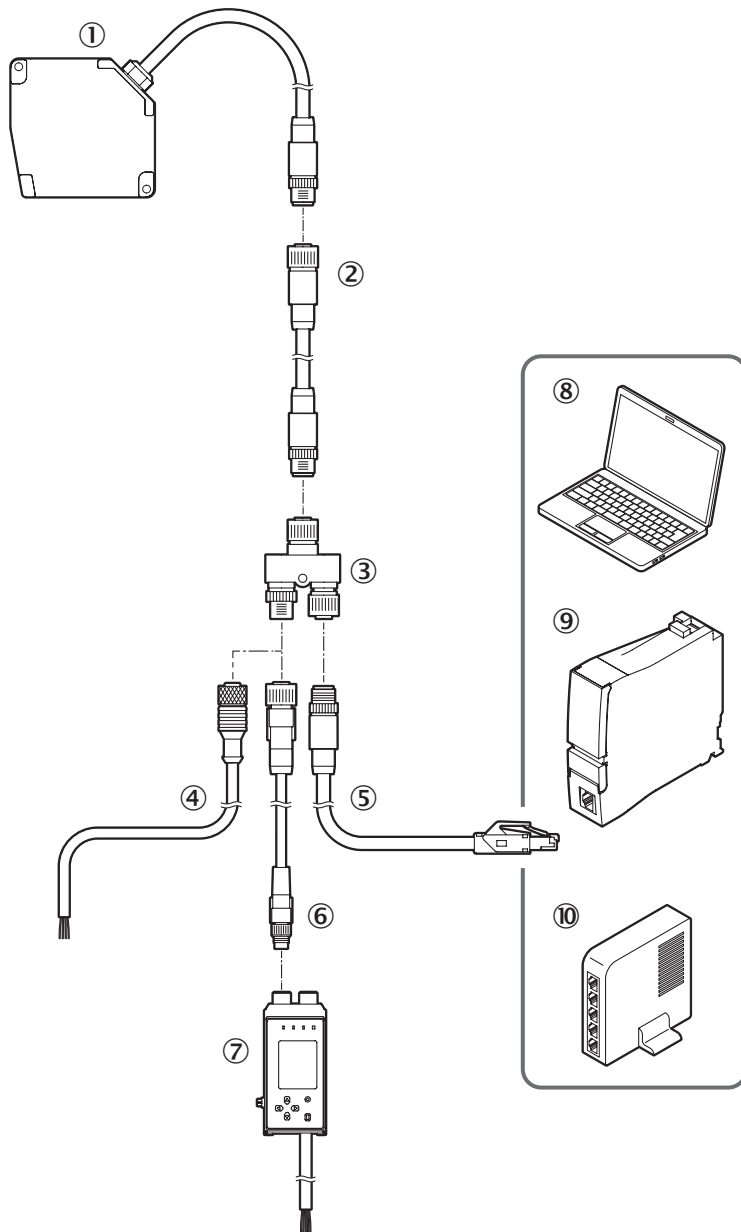

- ① OD5000
- ② Sensor head extension cable
- ③ Y-distribution (included with delivery)
- ④ Cable with open ends
- ⑤ Ethernet Connection cable
- ⑥ AOD1 connection cable, M12, 4-pin to M8, 4-pin
- ⑦ AOD1
- ⑧ PC
- ⑨ PLC
- ⑩ switch

### PIN assignment Y-junctions

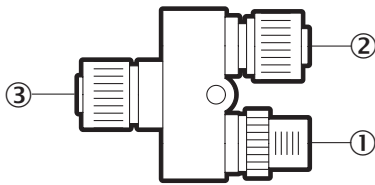

Y-distribution connections

- ① M12, 4-pin, A-coded
- ② M12, 5-pin, D-coded
- ③ M12, 8-pin, A-coded

### PIN assignment

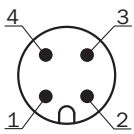

Connector M12, 4-pin, A-coded

- ① 24 V
- ② Input (MF) / RS485+
- ③ 0 V
- ④ Input (MF) / RS485-

### PIN assignment

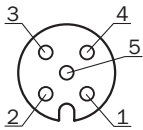

female connector M12, 5-pin, D-coded

- ① TxD+
- ② RxD+
- ③ TxD-
- ④ RxD-
- ⑤ nc

### PIN assignment

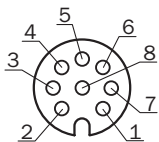

female connector M12, 8-pin, A-coded

- ① Input (MF) / RS485+
- ② 0 V
- ③ 24 V
- ④ TxD-
- ⑤ RxD+

- ⑥ TxD+
- ⑦ Input (MF) / RS485-
- ⑧ RxD-

Light spot size

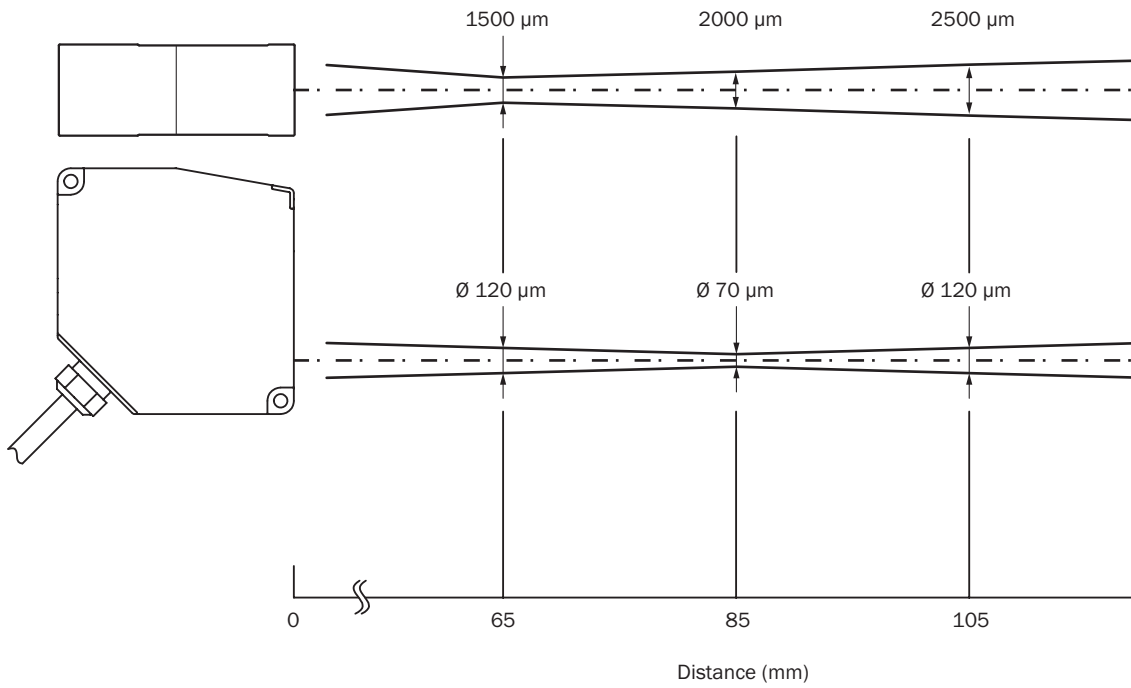

Linearity OD5000-C85W20 (diffuse)

Linearity (μm)

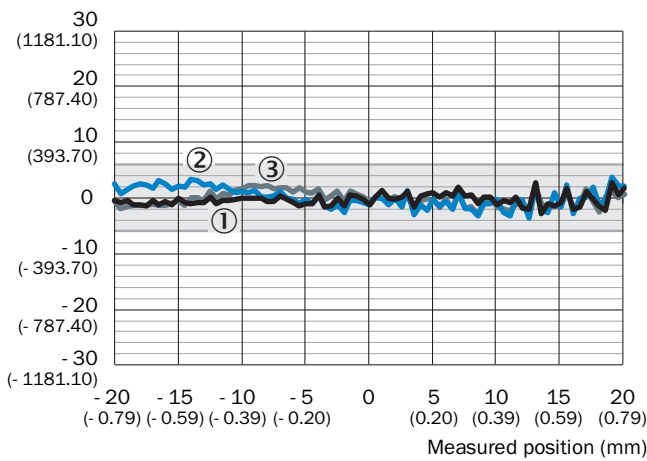

- ① white 60% remission factor
- ② black 9.5% remission factor
- ③ stainless steel

### Linearity OD5000-C85W20 (reflective)



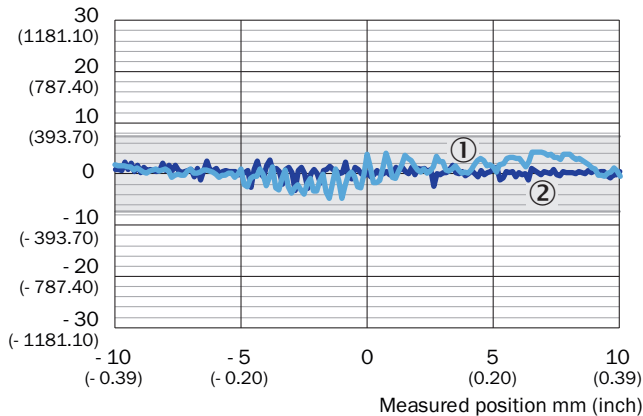



Linearity  $\mu\text{m}$  ( $\mu\text{in}$ )









- ① Mirror
- ② Glass

### Recommended accessories

Other models and accessories → [www.sick.com/OD5000](http://www.sick.com/OD5000)

	Brief description	Type	part no.
connectors and cables			
	<ul style="list-style-type: none"> <li>• <b>Connection type head A:</b> Female connector, M12, 8-pin, straight</li> <li>• <b>Connection type head B:</b> Male connector, M12, 8-pin, straight</li> <li>• <b>Cable:</b> 2 m, PUR</li> </ul>	DSC-1208-G02MA	6064004
	<ul style="list-style-type: none"> <li>• <b>Description:</b> Sensor/actuator cable, unshielded</li> <li>• <b>Connection type head A:</b> Female connector, M12, 4-pin, straight, A-coded</li> <li>• <b>Connection type head B:</b> Flying leads</li> <li>• <b>Signal type:</b> Sensor/actuator cable</li> <li>• <b>Cable:</b> 2 m, 4-wire, PUR, halogen-free</li> <li>• <b>Application:</b> Drag chain operation, Zones with oils and lubricants, Robot, Drag chain operation</li> </ul>	YF2A14-020UB3XLEAX	2095607
	<ul style="list-style-type: none"> <li>• <b>Connection type head A:</b> Male connector, M12, 4-pin, straight, D-coded</li> <li>• <b>Connection type head B:</b> Male connector, RJ45, 4-pin, straight</li> <li>• <b>Signal type:</b> Ethernet, PROFINET</li> <li>• <b>Cable:</b> 2 m, 4-wire, PUR, halogen-free</li> <li>• <b>Description:</b> Ethernet, shielded, PROFINET</li> <li>• <b>Application:</b> Drag chain operation, Zones with oils and lubricants</li> </ul>	YM2D24-020P-N1MRJA4	2106182
	<ul style="list-style-type: none"> <li>• <b>Description:</b> Sensor/actuator cable, unshielded</li> <li>• <b>Connection type head A:</b> Female connector, M12, 4-pin, straight, A-coded</li> <li>• <b>Connection type head B:</b> Flying leads</li> <li>• <b>Signal type:</b> Sensor/actuator cable</li> <li>• <b>Cable:</b> 0.6 m, 4-wire, PUR, halogen-free</li> <li>• <b>Application:</b> Drag chain operation, Zones with oils and lubricants, Robot, Drag chain operation</li> </ul>	YF2A14-C60UB3XLEAX	2145654
	<ul style="list-style-type: none"> <li>• <b>Description:</b> Sensor/actuator cable, unshielded</li> <li>• <b>Connection type head A:</b> Female connector, M12, 4-pin, straight, A-coded</li> <li>• <b>Connection type head B:</b> Flying leads</li> <li>• <b>Signal type:</b> Sensor/actuator cable</li> <li>• <b>Cable:</b> 1 m, 4-wire, PUR, halogen-free</li> <li>• <b>Application:</b> Drag chain operation, Zones with oils and lubricants, Robot, Drag chain operation</li> </ul>	YF2A14-010UB3XLEAX	2145655
	<ul style="list-style-type: none"> <li>• <b>Description:</b> Sensor/actuator cable, unshielded</li> <li>• <b>Connection type head A:</b> Female connector, M12, 4-pin, straight, A-coded</li> <li>• <b>Connection type head B:</b> Flying leads</li> <li>• <b>Signal type:</b> Sensor/actuator cable</li> <li>• <b>Cable:</b> 3 m, 4-wire, PUR, halogen-free</li> <li>• <b>Application:</b> Drag chain operation, Zones with oils and lubricants, Robot, Drag chain operation</li> </ul>	YF2A14-030UB3XLEAX	2145656

	Brief description	Type	part no.
integration modules and adapters			
	<ul style="list-style-type: none"> <li><b>Description:</b> OD Mini evaluation unit, master, 1 x Q, M8 male connector, 4-pin</li> </ul>	AOD1-MR24Q1	6054270
	<ul style="list-style-type: none"> <li><b>Description:</b> OD Mini evaluation unit, slave, 1 x Q, M8 male connector, 4-pin</li> </ul>	AOD1-SR24Q1	6054271
	<ul style="list-style-type: none"> <li><b>Description:</b> OD Mini evaluation unit, master, 2 x Q, M12 male connector, 5-pin</li> </ul>	AOD1-MR25Q2	6054272
	<ul style="list-style-type: none"> <li><b>Description:</b> OD Mini evaluation unit, slave, 2 x Q, M12 male connector, 5-pin</li> </ul>	AOD1-SR25Q2	6054273
	<ul style="list-style-type: none"> <li><b>Description:</b> OD Mini evaluation unit, OD5000 and OL1, master, 3 x Q, 1 x analog, open end cable, 2 m</li> </ul>	AOD1-MR27C4	6058195
	<ul style="list-style-type: none"> <li><b>Description:</b> OD Mini evaluation unit, OD5000 and OL1, slave, 3 x Q, 1 x analog, open end cable, 2 m</li> </ul>	AOD1-SR27C4	6058196

## SICK AT A GLANCE

SICK is one of the leading manufacturers of intelligent sensors and sensor solutions for industrial applications. A unique range of products and services creates the perfect basis for controlling processes securely and efficiently, protecting individuals from accidents and preventing damage to the environment.

We have extensive experience in a wide range of industries and understand their processes and requirements. With intelligent sensors, we can deliver exactly what our customers need. In application centers in Europe, Asia and North America, system solutions are tested and optimized in accordance with customer specifications. All this makes us a reliable supplier and development partner.

Comprehensive services complete our offering: SICK LifeTime Services provide support throughout the machine life cycle and ensure safety and productivity.

For us, that is “Sensor Intelligence.”

## WORLDWIDE PRESENCE:

Contacts and other locations –[www.sick.com](http://www.sick.com)